

## 22. Instrument Panel Assembly

### A: REMOVAL

#### 1. INSTRUMENT PANEL (EXCLUDING STEERING SUPPORT BEAM)

**CAUTION:**

Be careful not to damage the airbag system harness when servicing the instrument panel. Damage may cause the system to malfunction.

- 1) Disconnect the ground cable from battery.
- 2) Remove the front pillar upper trim. <Ref. to EI-60, REMOVAL, Upper Inner Trim.>
- 3) Remove the console box. <Ref. to EI-52, REMOVAL, Console Box.>
- 4) Remove the center console. <Ref. to EI-53, REMOVAL, Center Console.>
- 5) Remove the instrument panel lower cover. <Ref. to EI-50, REMOVAL, Instrument Panel Lower Cover.>
- 6) Remove the glove box. <Ref. to EI-51, REMOVAL, Glove Box.>
- 7) Remove the combination meter assembly. <Ref. to IDI-14, REMOVAL, Combination Meter.>
- 8) Remove the screws.

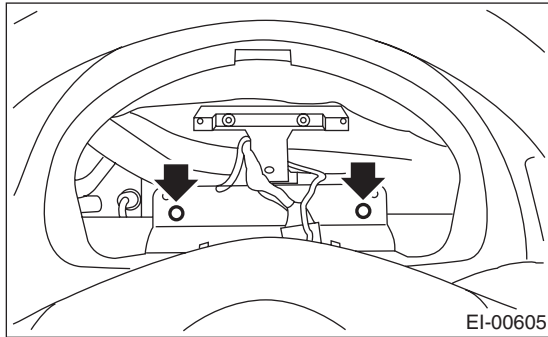

- 9) Remove the driver's side instrument panel side cover, and remove the screws.

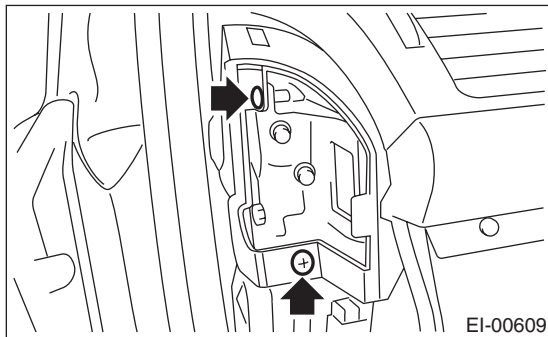

- 10) Remove the screw at the side of the center console.

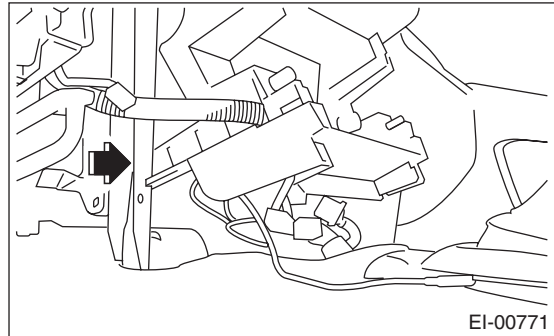

- 11) Remove the center air vent grille of the instrument panel. <Ref. to AC-45, CENTER GRILLE, REMOVAL, Air Vent Grille.>
- 12) Remove the screws.

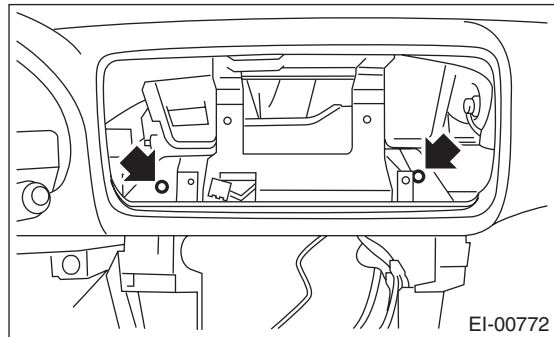

- 13) Remove the screws at the side of the passenger's side instrument panel.

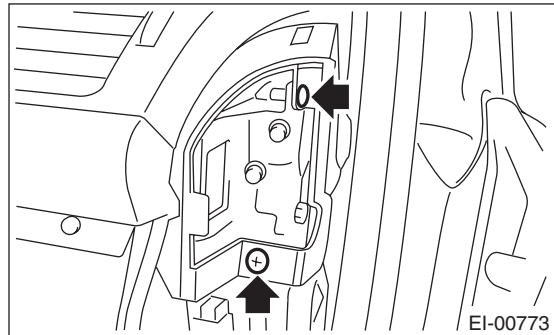

- 14) Remove the bolts securing the passenger's side airbag module to the steering support beam.

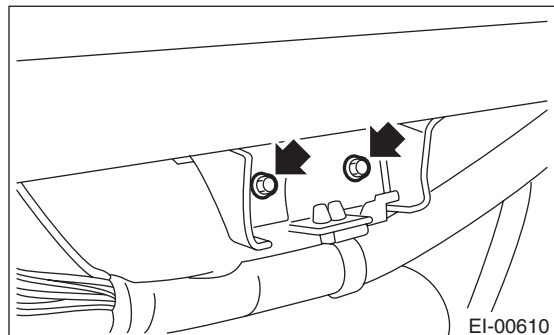

# Instrument Panel Assembly

## EXTERIOR/INTERIOR TRIM

15) Disconnect the connectors, and remove the instrument panel from vehicle body.

### NOTE:

- If necessary, make matching marks for easy re-assembly.
- When storing the removed instrument panel, be sure to prepare a table or the like to place the instrument panel, in order to prevent scratches or other damage to the panel.

16) Remove the side air vent grille. <Ref. to AC-45, REMOVAL, Air Vent Grille.>

17) Remove the heater vent duct. <Ref. to AC-47, REMOVAL, Heater Vent Duct.>

18) Loosen the screws to remove the center console frame.

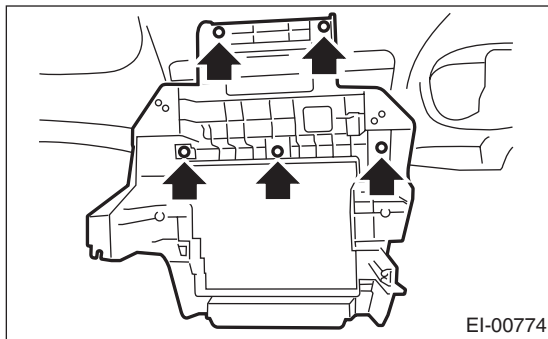

19) Loosen the screws to remove the meter bracket.

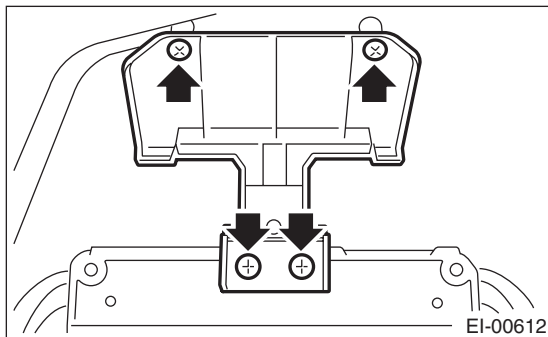

20) Loosen the screws to remove the instrument panel matching pins.

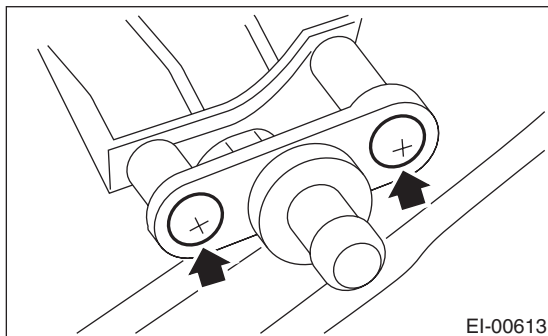

21) Loosen the screws to remove the glove box striker.

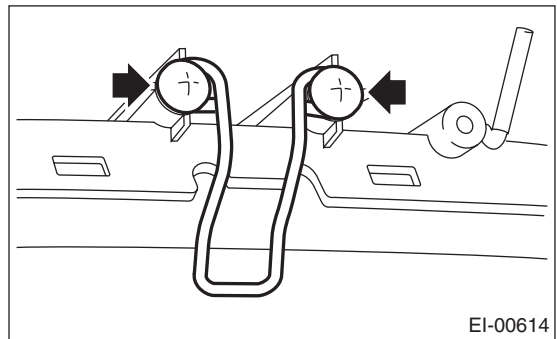

22) Remove the pawl, and remove the passenger's airbag module.

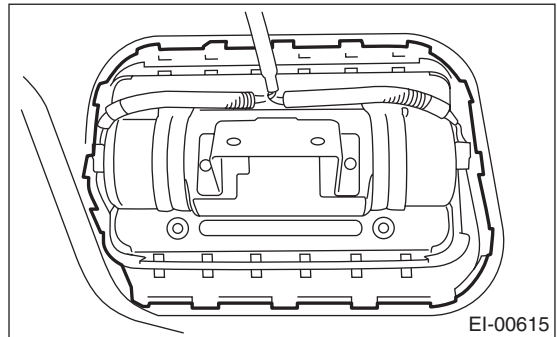

## 2. STEERING SUPPORT BEAM

1) Remove the instrument panel. <Ref. to EI-55, INSTRUMENT PANEL (EXCLUDING STEERING SUPPORT BEAM), REMOVAL, Instrument Panel Assembly.>

2) Remove the steering shaft assembly. <Ref. to PS-17, REMOVAL, Tilt Steering Column.>

3) Remove all harness clips, and remove the harness from the steering support beam.

### NOTE:

If necessary, make matching marks for easy re-assembly.

4) Remove the bolts and remove the steering support beam.

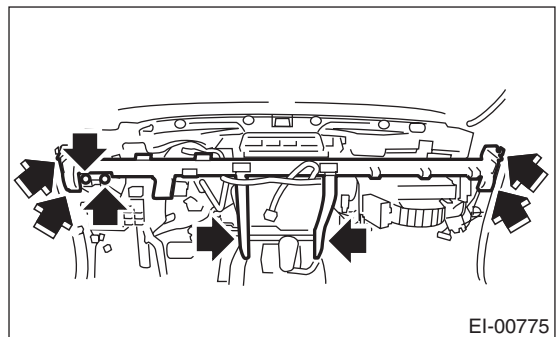

5) Remove the steering support beam bracket.

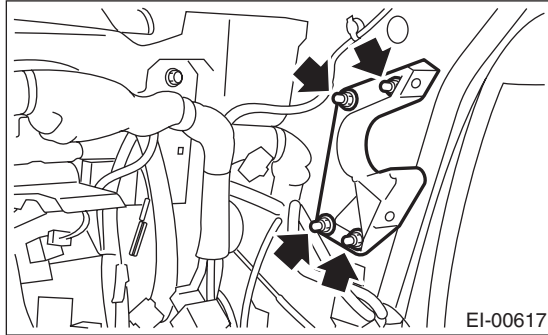

8) Loosen the bolts on the center console side.

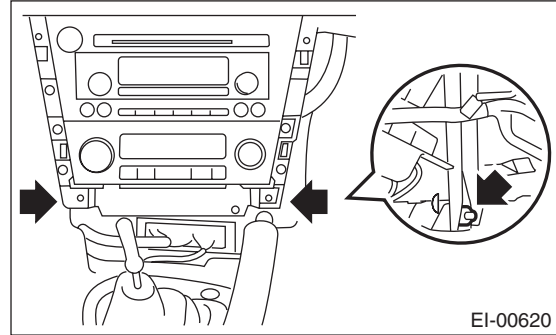

### 3. INSTRUMENT PANEL ASSEMBLY (INCLUDING STEERING SUPPORT BEAM)

#### CAUTION:

**Be careful not to damage the airbag system harness when servicing the instrument panel. Damage may cause the system to malfunction.**

- 1) Remove the front pillar upper trim. <Ref. to EI-60, REMOVAL, Upper Inner Trim.>
- 2) Remove the center console. <Ref. to EI-53, REMOVAL, Center Console.>
- 3) Remove the instrument panel lower cover. <Ref. to EI-50, REMOVAL, Instrument Panel Lower Cover.>
- 4) Remove the glove box. <Ref. to EI-51, REMOVAL, Glove Box.>
- 5) Remove the steering shaft assembly. <Ref. to PS-17, REMOVAL, Tilt Steering Column.>
- 6) Remove the driver's side instrument panel side cover, and remove the bolts.

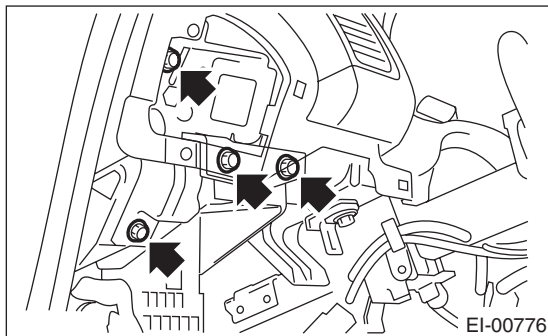

7) Remove the bolts at the side of the passenger's side instrument panel.

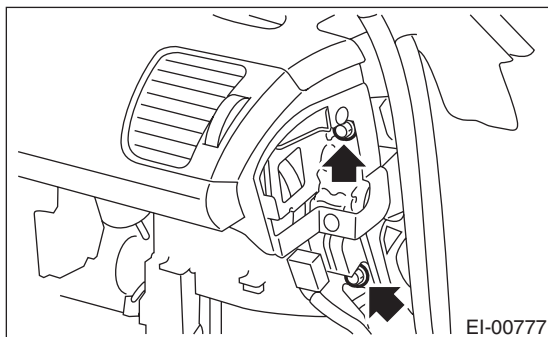

9) Disconnect the connectors, and remove the instrument panel assembly.

#### NOTE:

If necessary, make matching marks for easy reassembly.

### B: INSTALLATION

#### 1. INSTRUMENT PANEL (EXCLUDING STEERING SUPPORT BEAM)

1) Insert the matching pins (three places) on the instrument panel tip into the grommet (A) and (B) on the body panel side.

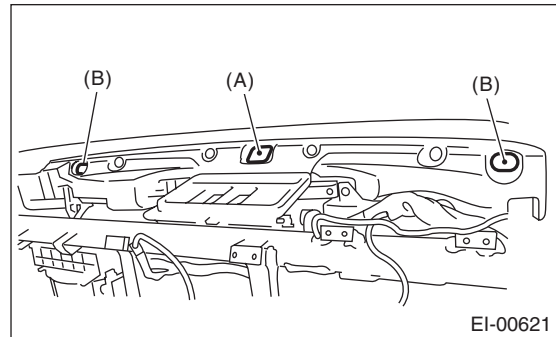

2) Check that the matching pins are inserted securely, and then route the harness.

3) Tighten the instrument panel with screws, and recheck the installation condition of instrument panel and harness routing.

# Instrument Panel Assembly

## EXTERIOR/INTERIOR TRIM

4) Install in the reverse order of removal.

### NOTE:

How to install insulator and pad;

- Adhesive

Use polyurethane adhesive. When assembling the instrument panel assembly, wait until the adhesive has evaporated to prevent filling of the smell in the compartment.

- Double-sided tape

Use commercial double-sided tape. (Use strong double-sided adhesive tape.)

- Locations

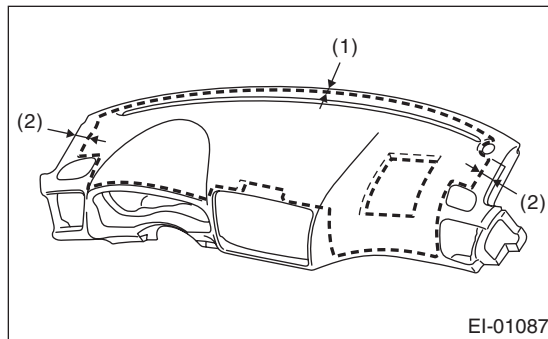

(1) 10 mm

(2) 40 mm

Apply at a position spaced by 10mm from the instrument panel front end, and 40 mm from the ends on both sides.

## 2. STEERING SUPPORT BEAM

1) Temporarily tighten the steering support beam with bolts, and then route the harness.

2) Make sure that there is no mutual interference in each pedal, and then tighten each bolt.

### Tightening torque:

**25 N·m (25.5 kgf·m, 18 ft·lb)**

3) Install in the reverse order of removal.

## 3. INSTRUMENT PANEL ASSEMBLY (INCLUDING STEERING SUPPORT BEAM)

1) Insert the matching pins (three places) on the instrument panel tip into the grommet (A) and (B) on the body panel side.

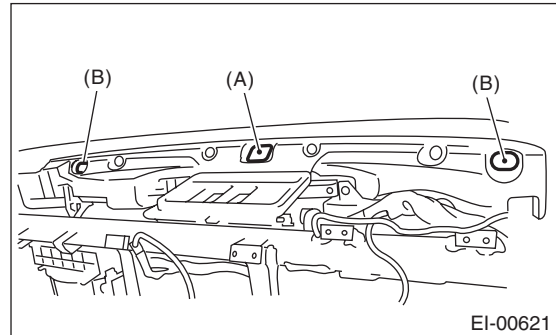

2) Check that the matching pins are inserted securely, and then route the harness.

3) Temporarily tighten the steering support beam with bolts, and then route the harness.

4) Make sure that there is no mutual interference in each pedal, and then tighten each bolt.

### Tightening torque:

**25 N·m (25.5 kgf·m, 18 ft·lb)**

5) Install in the reverse order of removal.