

37.Ornament

A: INSTALLATION

1. LETTER MARK

Adhere the letter mark according to the following measurements.

- Sedan model

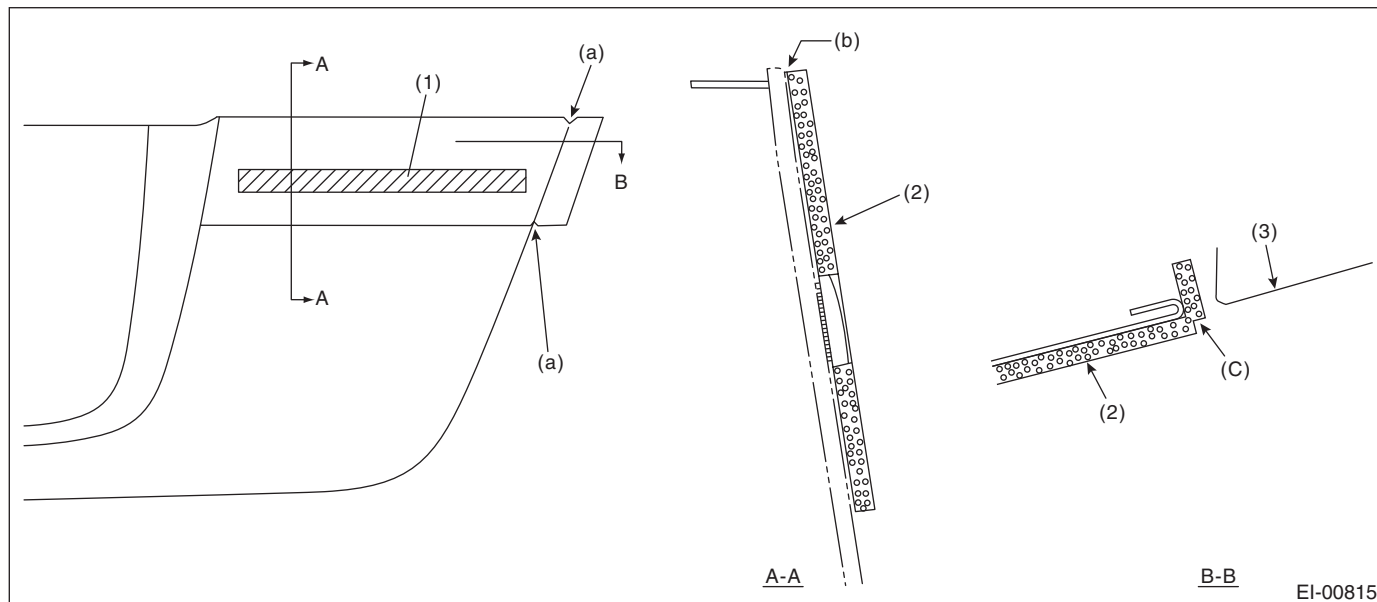

EI-00815

(a) Apply the application tape by aligning the cut out to the edge of the trunk lid garnish.

(b) Apply the application tape by aligning with the end of the radius, at the upper edge of the trunk lid garnish.

(c) Align the slit of the application tape to the panel end.

(1) Letter mark

(2) Application tape

(3) Rear combination light

Ornament

EXTERIOR/INTERIOR TRIM

• Wagon model

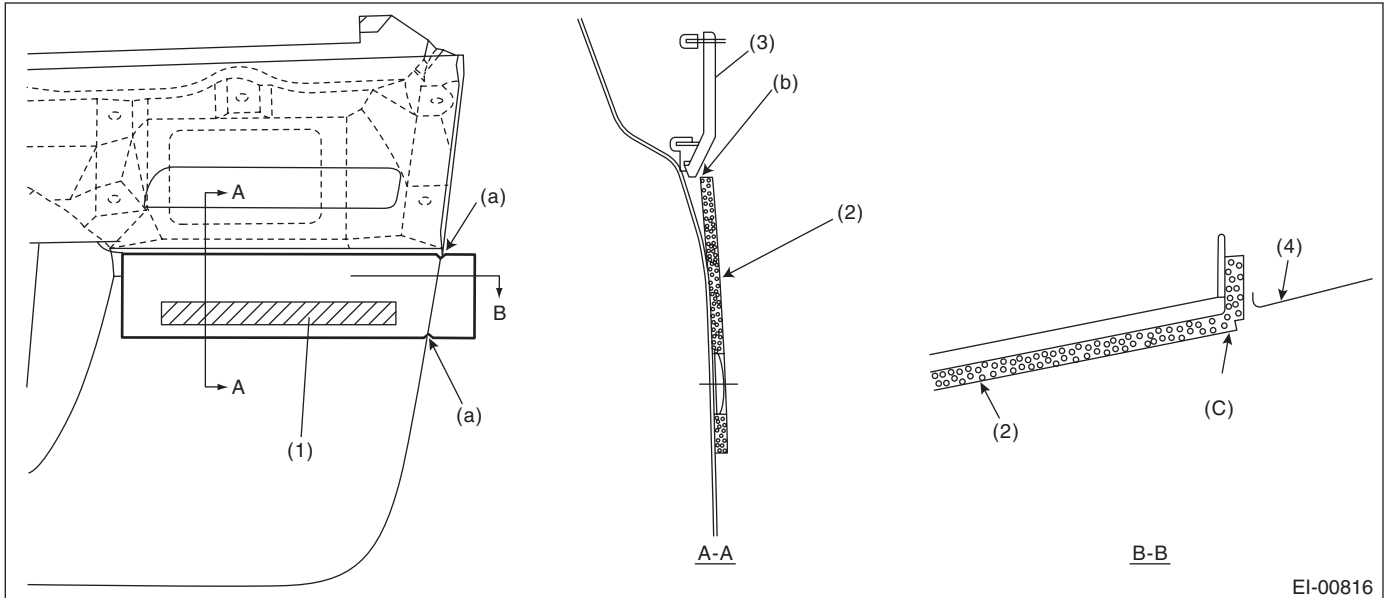

EI-00816

(a) Apply the application tape by aligning the cut out to the edge of the rear gate panel.

(b) Apply the application tape by aligning it with the outer bottom end of the rear gate garnish.

(c) Align the slit of the application tape to the panel end.

(1) Letter mark

(3) Rear gate garnish

(4) Rear combination light

(2) Application tape

2. AWD STICKER

Apply the AWD sticker from inside of the glass according to the following dimensions.

• Sedan model

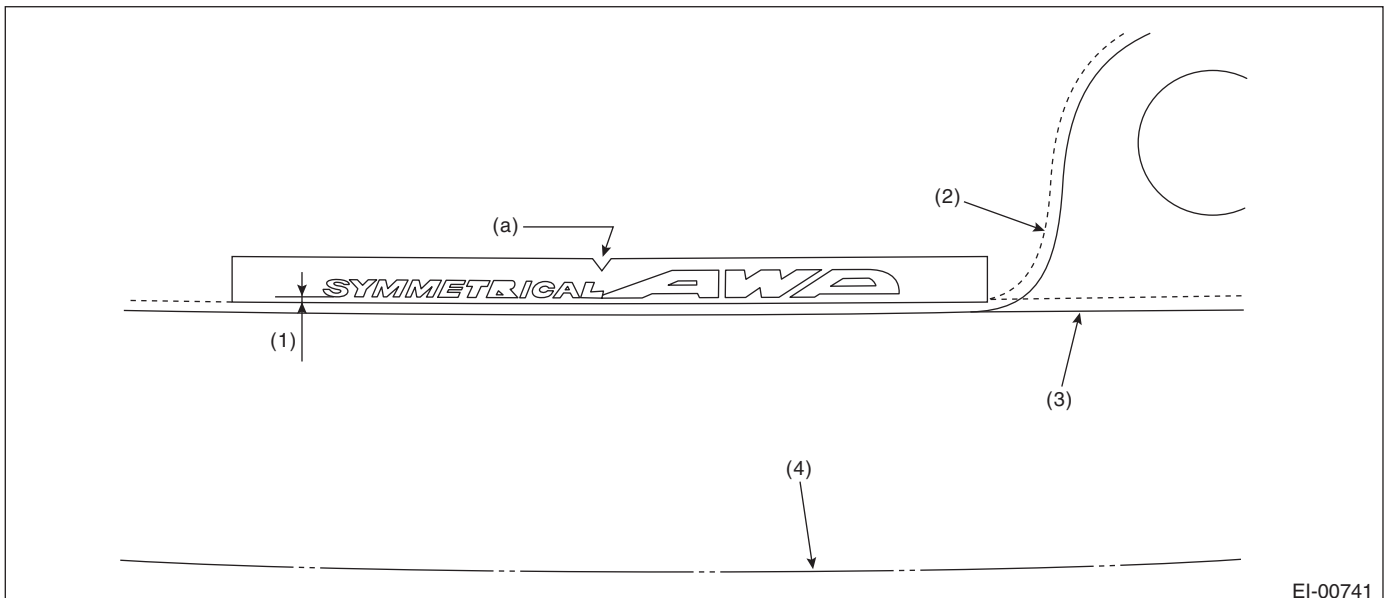

EI-00741

(a) Apply the application tape by aligning the cut out to the edge of the rear glass center.

(1) 1 mm (0.04 in)

(3) Gradation end of the ceramic print (without rear wiper)

(4) End of rear glass

(2) Gradation end of the ceramic print (with rear wiper)

- Wagon model (RH side)

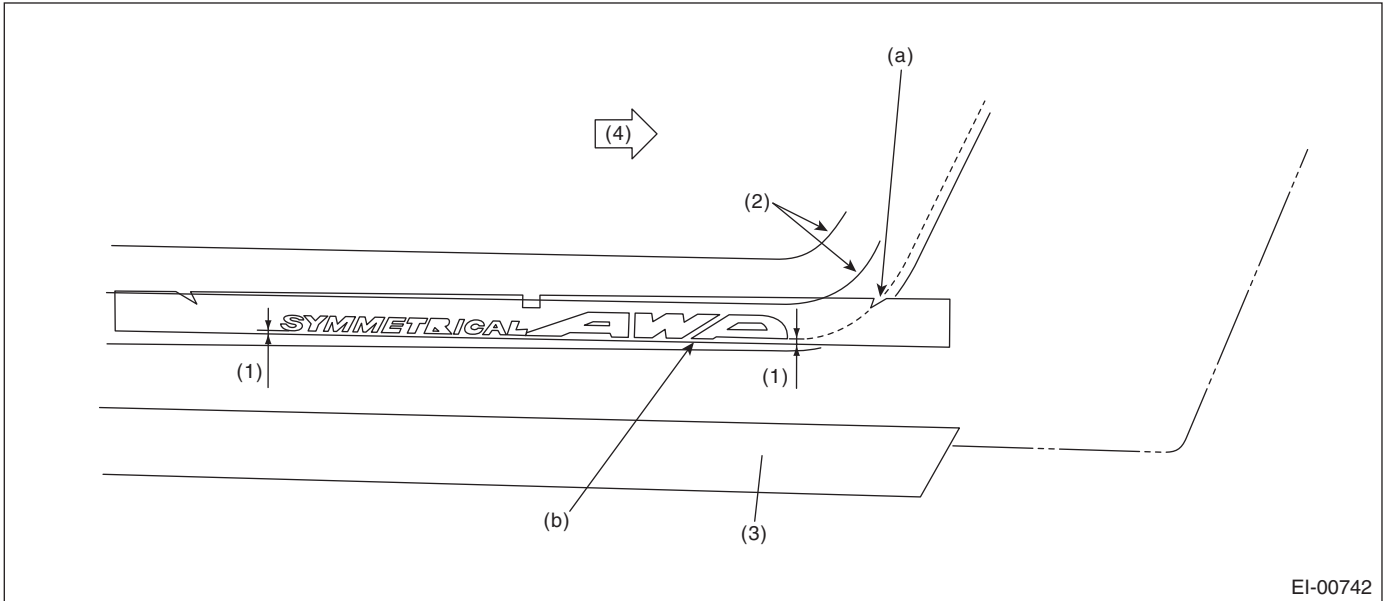

EI-00742

- Wagon model (LH side)

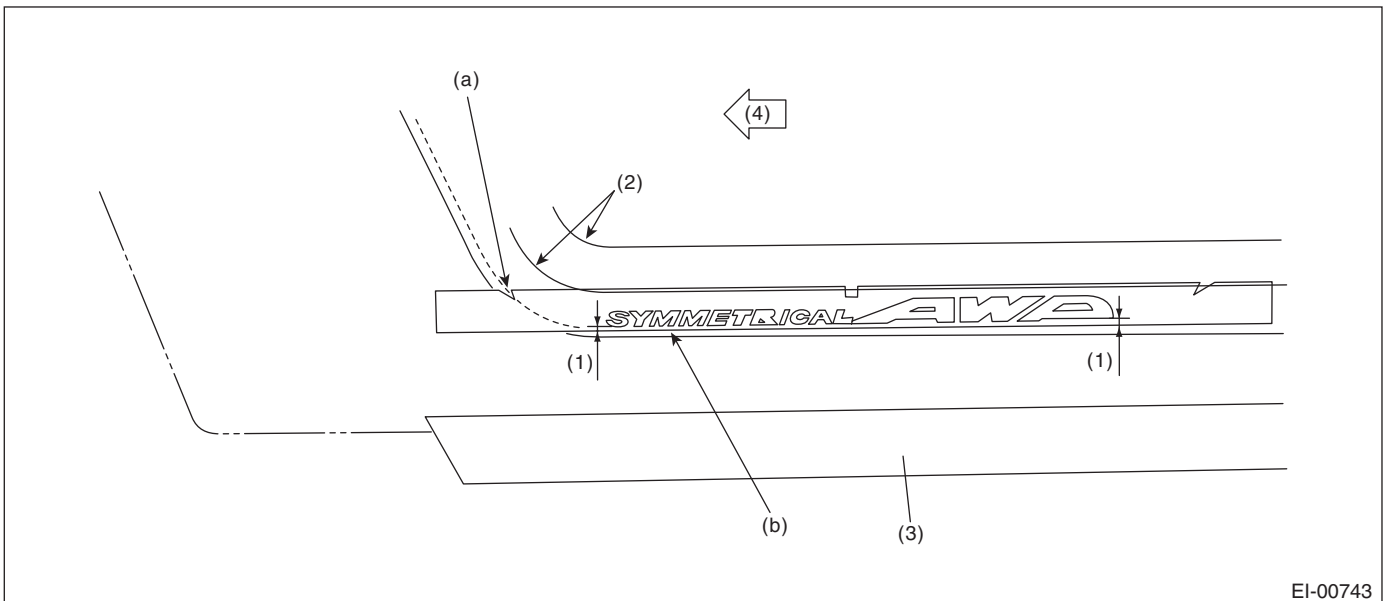

EI-00743

(a) Apply the application tape by aligning the cut out to the ceramic print.

(b) Gradation end of the ceramic print

(1) 1 mm (0.04 in)

(3) Molding

(4) Front side of vehicle

(2) Glass antenna wire

Ornament

EXTERIOR/INTERIOR TRIM

EXTERIOR BODY PANELS



	Page
1. General Description	2
2. Front Hood	13
3. Front Fender	15
4. Front Door	16
5. Front Sealing Cover	19
6. Rear Door	20
7. Rear Sealing Cover	23
8. Trunk Lid	24
9. Rear Gate	26