

General Description

HVAC SYSTEM (AUTO A/C) (DIAGNOSTICS)

2. General Description

A: CAUTION

- 1) Never connect the battery in reverse polarity.
 - Doing so may immediately damage the auto A/C control module.
- 2) Do not disconnect the battery terminals while the engine is running.
 - A large counter electromotive force will be generated in the generator, and this voltage may damage electronic parts such as auto A/C control module etc.
- 3) Before disconnecting the connectors of sensors and the auto A/C control module, be sure to turn off the ignition switch.
 - Auto A/C control module may be damaged.
- 4) Every A/C-related part is a precision part. Do not drop them.
- 5) Airbag system wiring harness is routed near the A/C control panel and junction box.

CAUTION:

- The airbag system wiring harnesses and connectors are all yellow in color. Do not use the electrical test equipment on these circuits.
- Be careful not to damage the airbag system wiring harness when servicing the A/C control panel and junction box.

B: INSPECTION

Before performing the diagnosis, check the following items which may cause problems in the A/C system.

1. BATTERY

- 1) Measure the battery voltage and specific gravity of electrolyte.

Standard voltage: 12 V

Specific gravity: Above 1.260

- 2) Check the condition of the fuses for A/C system power supply and other fuses.
- 3) Check the condition of harness and harness connector connections.

2. ASPIRATOR HOSE

- 1) Turn the ignition switch to ON, and press the A/C switch.
- 2) Turn the temperature control dial to maximum hot position.
- 3) Turn the air flow control dial to "DEF" position.
- 4) Turn the fan speed control dial to 4th position.
- 5) Put a strip of paper close to the front side of in-vehicle sensor suction port (A) located in the driver's side console side panel, and check that air is being sucked into the port by seeing the paper moving towards the port.

NOTE:

Be careful not to let the paper get sucked into the port.

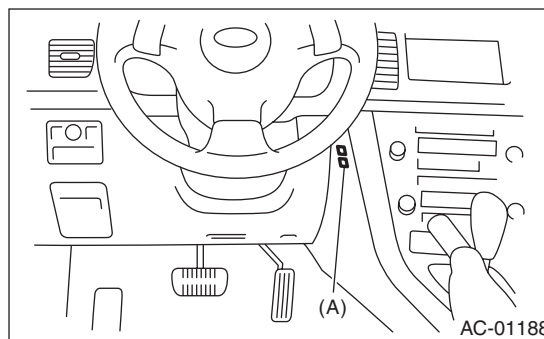

- 6) If the paper does not move at all, remove the driver's side console side panel <Ref. to EI-53, REMOVAL, Center Console.> and check for improper connection of the aspirator hose, in-vehicle sensor and heater unit, and repair them if necessary.

3. A/C LINE

Check the connection for A/C line (A) and lower side high-pressure pipe.

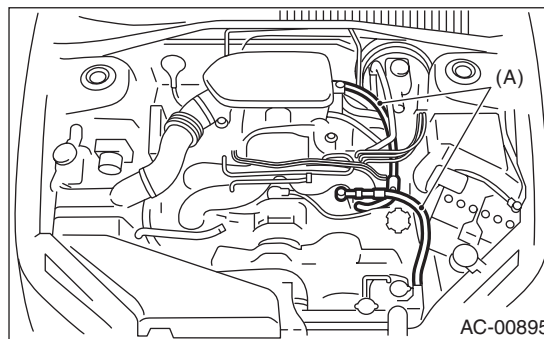

4. CONTROL LINKAGE

- 1) Check the state of mode door linkage.
- 2) Check the state of air mix door linkage.
- 3) Check the state of RESH/RECIRC door linkage.

General Description

HVAC SYSTEM (AUTO A/C) (DIAGNOSTICS)

5. CONTROL SWITCHES

Start the engine and warm-up completely.

1) Inspection using switches

No.	Point to check	Switch operation	Judgment standard
1	OFF switch	Press the OFF switch.	Setting temperature display goes out. <ul style="list-style-type: none"> • Blower fan: OFF • Inlet opening: FRESH • Compressor: OFF
2	AUTO switch, driver's side temperature control dial and passenger's side temperature control dial	1) Press the AUTO switch. 2) Turn the temperature control dial to the left fully, and set to 18°C (65°F) (maximum cool position).	AUTO display illuminates. <ul style="list-style-type: none"> • Outlet air temperature: COOL • Blower fan: HI (AUTO) • Outlet opening: FACE • Inlet opening: AUTO • Compressor: AUTO
		3) Turn the temperature control dial to the right slowly, and change the setting from 18°C (65°F) (maximum cool position) to 32°C (90°F).	<ul style="list-style-type: none"> • Outlet air temperature: COOL → HOT • Blower fan: AUTO • Outlet opening: FACE → B/L → FOOT • Inlet opening: AUTO • Compressor: AUTO
		4) Turn the temperature control dial to the right fully, and set to 32°C (90°F) (maximum hot position).	<ul style="list-style-type: none"> • Outlet air temperature: HOT • Blower fan: HI (AUTO) • Outlet opening: FOOT • Inlet opening: FRESH (AUTO) • Compressor: AUTO
3	Defroster switch	Press the defroster switch.	Defroster switch indicator illuminates. <ul style="list-style-type: none"> • Outlet air temperature: AUTO • Blower fan: AUTO • Outlet opening: DEF • Inlet opening: FRESH • Compressor: ON
4	FRESH/RECIRC switch	Press the FRESH/RECIRC switch.	Inlet opening switches RECIRC → FRESH or FRESH → RECIRC each time pressing the switch.
5	MODE switch	Press the MODE switch.	Outlet opening switches FACE → B/L → FOOT → F/D each time pressing the switch.
6	FAN switch	Press the FAN (+) switch.	Inlet opening switches LO → M1 → M2 → M3 → M4 → HI each time pressing the switch.

2) Compressor operation inspection

No.	Point to check	Switch operation	Judgment standard
1	COMPRESSOR	1) Turn the A/C switch to ON. 2) Set the FAN switch between LO and HI.	Compressor: ON

3) Inspection of illumination control

No.	Point to check	Switch operation	Judgment standard
1	Illumination	Turn the lighting switch to ON.	Illumination comes on.