

Diagnostic Procedure for Actuators

HVAC SYSTEM (AUTO A/C) (DIAGNOSTICS)

7. Diagnostic Procedure for Actuators

A: INTAKE DOOR ACTUATOR

TRUBLE SYMPTOM:

FRESH/RECIRC mode is not changed.

WIRING DIAGRAM:

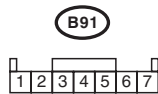
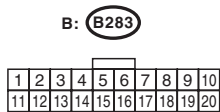
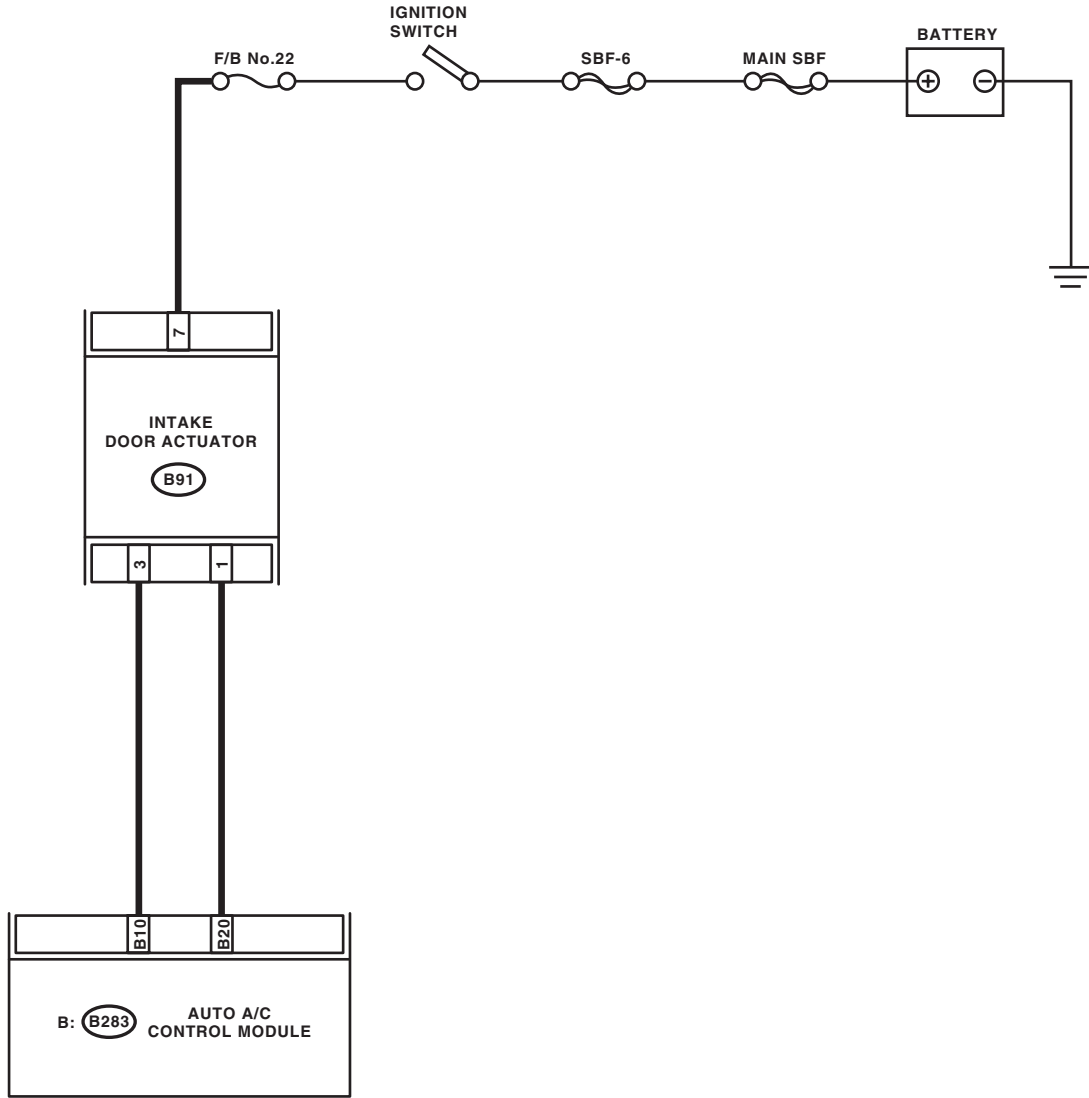

AC-01192

Diagnostic Procedure for Actuators

HVAC SYSTEM (AUTO A/C) (DIAGNOSTICS)

Step	Check	Yes	No
<p>1</p> <p>CHECK POWER SUPPLY FOR INTAKE DOOR ACTUATOR.</p> <p>1) Turn the ignition switch to OFF. 2) Disconnect the intake door actuator connector. 3) Turn the ignition switch to ON. 4) Measure the voltage between intake door actuator connector and chassis ground.</p> <p>Connector & terminal (B91) No. 7 (+) — Chassis ground (-):</p>	<p>Is the voltage 7 V (at normal temperature)?</p>	<p>Go to step 2.</p>	<p>Check for open or short circuit in the harness between intake door actuator and fuse.</p>
<p>2</p> <p>CHECK HARNESS BETWEEN AUTO A/C CONTROL MODULE AND INTAKE DOOR ACTUATOR.</p> <p>1) Turn the ignition switch to OFF. 2) Disconnect the auto A/C control module connector. 3) Measure the resistance between intake door actuator connector and auto A/C control module connector.</p> <p>Connector & terminal (B283) No. 10 — (B91) No. 3: (B283) No. 20 — (B91) No. 1:</p>	<p>Is the resistance less than 1 Ω?</p>	<p>Go to step 3.</p>	<p>Repair the harness between auto A/C control module and intake door actuator.</p>
<p>3</p> <p>CHECK OPERATION OF INTAKE DOOR ACTUATOR.</p> <p>1) Connect the intake door actuator connector. 2) Ground the auto A/C control module connector with a suitable wire. 3) Turn the ignition switch to ON, and check the operation of intake door actuator.</p> <p>Connector & terminal (B283) No. 10 — Chassis ground:</p>	<p>Does the actuator move to the FRESH side?</p>	<p>Go to step 4.</p>	<p>Replace the intake door actuator.</p>
<p>4</p> <p>CHECK OPERATION OF INTAKE DOOR ACTUATOR.</p> <p>1) Turn the ignition switch to OFF. 2) Ground the auto A/C control module connector with a suitable wire. 3) Turn the ignition switch to ON, and check the operation of intake door actuator.</p> <p>Connector & terminal: (B283) No. 20 — Chassis ground:</p>	<p>Does the actuator move to the RECIRC side?</p>	<p>Replace the auto A/C control module.</p>	<p>Replace the intake door actuator.</p>

Diagnostic Procedure for Actuators

HVAC SYSTEM (AUTO A/C) (DIAGNOSTICS)

B: MODE DOOR ACTUATOR

TROUBLE SYMPTOM:

Air flow outlet is not changed.

WIRING DIAGRAM:

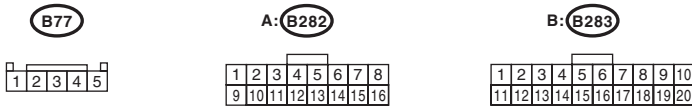
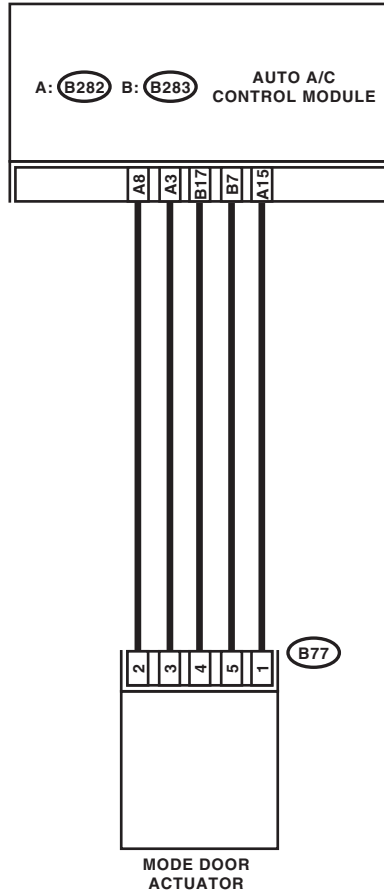

AC-00827

Diagnostic Procedure for Actuators

HVAC SYSTEM (AUTO A/C) (DIAGNOSTICS)

Step	Check	Yes	No
1 CHECK POWER SUPPLY FOR MODE DOOR ACTUATOR POSITION SENSOR. 1) Turn the ignition switch to OFF. 2) Disconnect the mode door actuator connector. 3) Turn the ignition switch and AUTO switch to ON. 4) Measure the voltage between auto A/C control module connector terminals. <i>Connector & terminal</i> <i>(B282) No. 8 (+) — (B282) No. 15 (-):</i>	Is the voltage approx. 5 V?	Go to step 2.	Replace the auto A/C control module.
2 CHECK POWER SUPPLY FOR MODE DOOR ACTUATOR. Measure the voltage between auto A/C control module connector and chassis ground after turning the air flow control switch to FACE position. <i>Connector & terminal</i> <i>(B283) No. 7 (+) — Chassis ground (-):</i>	Is the voltage 7 V (at normal temperature)?	Go to step 3.	Replace the auto A/C control module.
3 CHECK POWER SUPPLY FOR MODE DOOR ACTUATOR. Measure the voltage between auto A/C control module connector and chassis ground after turning the air flow control switch to DEF position. <i>Connector & terminal</i> <i>(B283) No. 17 (+) — Chassis ground (-):</i>	Is the voltage 7 V (at normal temperature)?	Go to step 4.	Replace the auto A/C control module.
4 CHECK HARNESS BETWEEN AUTO A/C CONTROL MODULE AND MODE DOOR ACTUATOR. 1) Turn the A/C and ignition switch to OFF. 2) Disconnect the auto A/C control module connector. 3) Measure the resistance between auto A/C control module and mode door actuator connector. <i>Connector & terminal</i> <i>(B77) No. 1 — (B282) No. 15:</i> <i>(B77) No. 2 — (B282) No. 8:</i> <i>(B77) No. 3 — (B282) No. 3:</i> <i>(B77) No. 4 — (B283) No. 17:</i> <i>(B77) No. 5 — (B283) No. 7:</i>	Is the resistance less than 1 Ω ?	Go to step 5.	Repair the harness between auto A/C control module and mode door actuator.
5 CHECK MODE DOOR ACTUATOR POSITION SWITCH SIGNAL. 1) Connect the connector of auto A/C control module and mode door actuator. 2) Turn the ignition switch and AUTO switch to ON. 3) Check the voltage between auto A/C control module connector terminals while changing the mode between DEF and FACE. <i>Connector & terminal</i> <i>(B282) No. 3 (+) — (B282) No. 15 (-):</i>	Does the voltage change between 1 V (DEF) and 4 V (FACE)?	Go to step 6.	Replace the mode door actuator.
6 CHECK POOR CONTACT. Check poor contact of auto A/C control module and connector.	Is there poor contact in the connector?	Repair the connector.	Replace the auto A/C control module.

Diagnostic Procedure for Actuators

HVAC SYSTEM (AUTO A/C) (DIAGNOSTICS)

C: AIR MIX DOOR ACTUATOR

TROUBLE SYMPTOM:

Outlet air temperature does not change.

WIRING DIAGRAM:

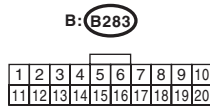
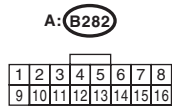
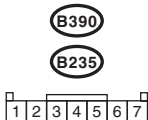
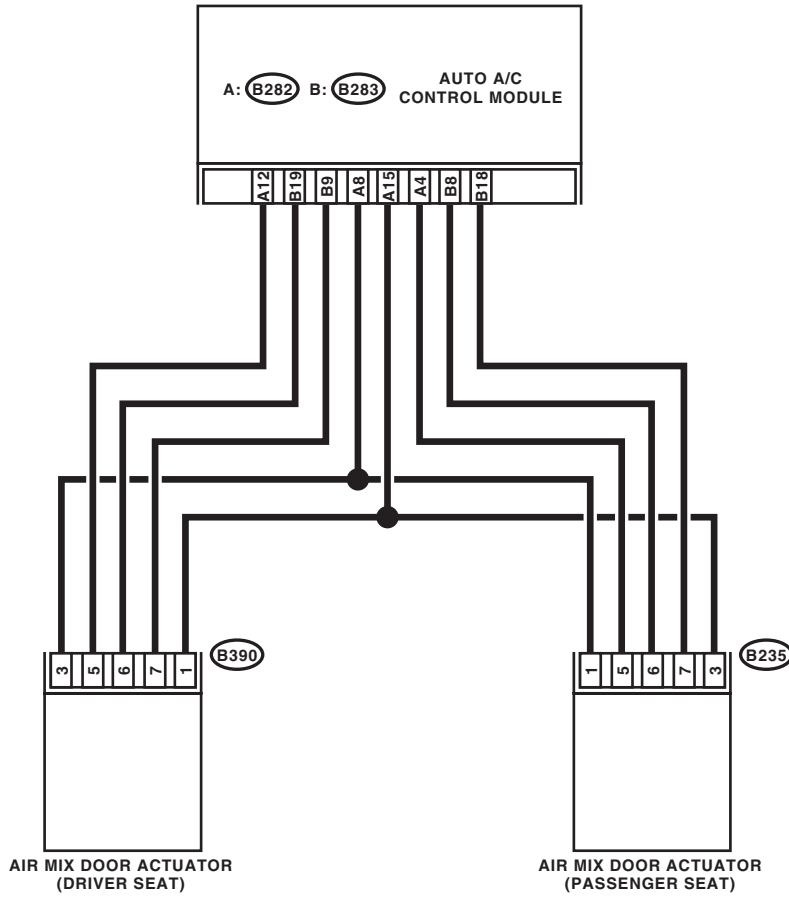

AC-01170

Diagnostic Procedure for Actuators

HVAC SYSTEM (AUTO A/C) (DIAGNOSTICS)

Step	Check	Yes	No
<p>1</p> <p>CHECK POWER SUPPLY FOR AIR MIX DOOR ACTUATOR POSITION SWITCH.</p> <p>1) Turn the ignition switch to OFF. 2) Disconnect the air mix door actuator connector. 3) Turn the ignition switch and AUTO switch to ON. 4) Measure the voltage between auto A/C control module connector terminals.</p> <p>Connector & terminal (B282) No. 8 (+) — (B282) No. 15 (-):</p>	Is the voltage approx. 5 V?	Go to step 2.	Replace the auto A/C control module.
<p>2</p> <p>CHECK POWER SUPPLY FOR AIR MIX DOOR ACTUATOR.</p> <p>Measure the voltage between auto A/C control module connector and chassis ground after turning the temperature control dial to maximum COOL position.</p> <p>Connector & terminal Driver's side (B283) No. 9 (+) — Chassis ground (-): Passenger's side (B283) No. 8 (+) — Chassis ground (-):</p>	Is the voltage 7 V (at normal temperature)?	Go to step 3.	Replace the auto A/C control module.
<p>3</p> <p>CHECK POWER SUPPLY FOR AIR MIX DOOR ACTUATOR.</p> <p>Measure the voltage between auto A/C control module connector and chassis ground after turning the temperature control dial to maximum HOT position.</p> <p>Connector & terminal Driver's side (B283) No. 19 (+) — Chassis ground (-): Passenger's side (B283) No. 18 (+) — Chassis ground (-):</p>	Is the voltage 7 V (at normal temperature)?	Go to step 4.	Replace the auto A/C control module.
<p>4</p> <p>CHECK HARNESS BETWEEN AUTO A/C CONTROL MODULE AND AIR MIX DOOR ACTUATOR.</p> <p>1) Turn the A/C and ignition switch to OFF. 2) Disconnect the auto A/C control module connector. 3) Measure the resistance between auto A/C control module and air mix door actuator connector.</p> <p>Connector & terminal Driver's side (B390) No. 1 — (B282) No. 15: (B390) No. 3 — (B282) No. 8: (B390) No. 5 — (B282) No. 12: (B390) No. 6 — (B283) No. 19: (B390) No. 7 — (B283) No. 9: Passenger's side (B235) No. 1 — (B282) No. 8: (B235) No. 3 — (B282) No. 15: (B235) No. 5 — (B282) No. 4: (B235) No. 6 — (B283) No. 8: (B235) No. 7 — (B283) No. 18:</p>	Is the resistance less than 1 Ω ?	Go to step 5.	Repair the harness between auto A/C control module and air mix door actuator.

Diagnostic Procedure for Actuators

HVAC SYSTEM (AUTO A/C) (DIAGNOSTICS)

Step	Check	Yes	No
5 CHECK AIR MIX DOOR ACTUATOR POSITION SWITCH SIGNAL. 1) Connect the connector of auto A/C control module and air mix door actuator. 2) Turn the ignition switch and AUTO switch ON. 3) Check the voltage between auto A/C control module connector terminals while changing the setting temperature between maximum COOL and maximum HOT. Connector & terminal Driver's side (B282) No. 12 (+) — (B282) No. 15 (-): Passenger's side (B282) No. 4 (+) — (B282) No. 15 (-):	Does the voltage change between 1 V (Max. HOT) and 4 V (Max. COOL)?	Go to step 6.	Replace the air mix door actuator.
6 CHECK POOR CONTACT. Check poor contact of auto A/C control module and connector.	Is there poor contact in the connector?	Repair the connector.	Replace the auto A/C control module.