

Refrigerant Charging Procedure

HVAC SYSTEM (HEATER, VENTILATOR AND A/C)

4. Refrigerant Charging Procedure

A: PROCEDURE

CAUTION:

- During operation, be sure to wear protective goggles and protective gloves.
- Before charging the refrigerant, evacuate the system to remove small amounts of moisture remaining in the system.

The moisture in the system can be completely evacuated only under the minimum vacuum level. The minimum vacuum level affects the temperature in the system.

- The list below shows the vacuum values necessary to boil water at various temperatures. In addition, the vacuum levels indicated on the gauge are approx. 3.3 kPa (25 mmHg, 0.98 inHg) lower than those measured at 304.8 m (1,000 ft) above sea level.

Vacuum level required to boil water (at sea level)	
Temperature	Vacuum
1.7°C (35°F)	100.9 kPa (757 mmHg, 29.8 inHg)
7.2°C (45°F)	100.5 kPa (754 mmHg, 29.7 inHg)
12.8°C (55°F)	99.8 kPa (749 mmHg, 29.5 inHg)
18.3°C (65°F)	99.2 kPa (744 mmHg, 29.3 inHg)
23.9°C (75°F)	98.5 kPa (739 mmHg, 29.1 inHg)
29.4°C (85°F)	97.2 kPa (729 mmHg, 28.7 inHg)
35°C (95°F)	95.8 kPa (719 mmHg, 28.3 inHg)

- 1) Close the valves on low-/high-pressure sides of the manifold gauge.

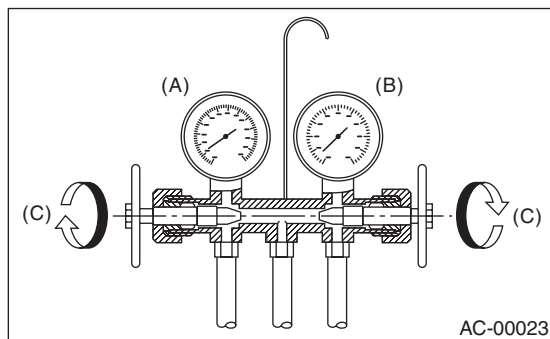

- (A) Low-pressure gauge (Compound pressure gauge)
- (B) High-pressure gauge
- (C) Close

- 2) Install the low-/high-pressure hoses to the corresponding service ports on the vehicle.
- 3) Connect the center hose of the manifold gauge set with the vacuum pump.

- 4) Carefully open the valves on the low-/high-pressure sides to activate the vacuum pump.

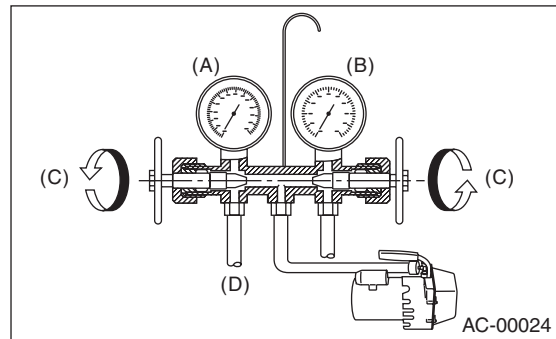

- (A) Low-pressure gauge (Compound pressure gauge)
- (B) High-pressure gauge
- (C) Slowly open
- (D) Vacuum pump turn on

- 5) After the low-pressure gauge reaches 100.0 kPa (750 mmHg, 29.5 inHg) or higher, evacuate the system for approx. 15 minutes. (Continue evacuation).

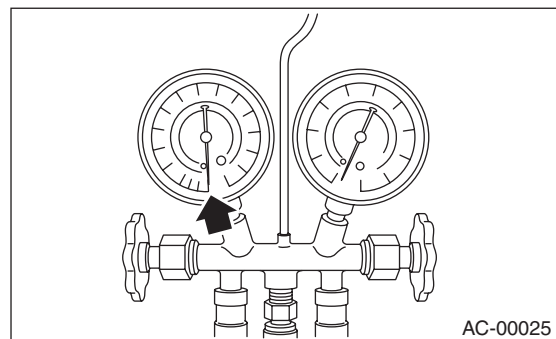

- 6) After 15 minutes of evacuation, if the reading shows 100.0 kPa (750 mmHg, 29.5 inHg) or higher, close the valves on the both sides to stop the vacuum pump.

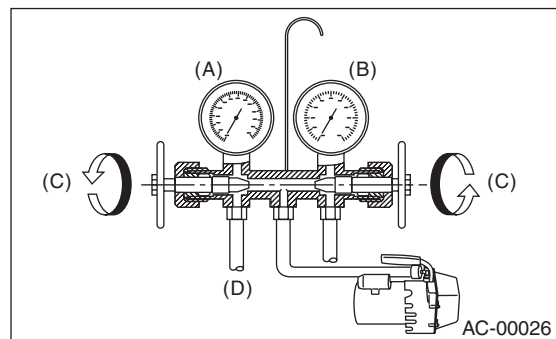

- (A) Low-pressure gauge (Compound pressure gauge)
- (B) High-pressure gauge
- (C) Close
- (D) Vacuum pump turn off

Refrigerant Charging Procedure

HVAC SYSTEM (HEATER, VENTILATOR AND A/C)

7) Note the low-pressure gauge reading.

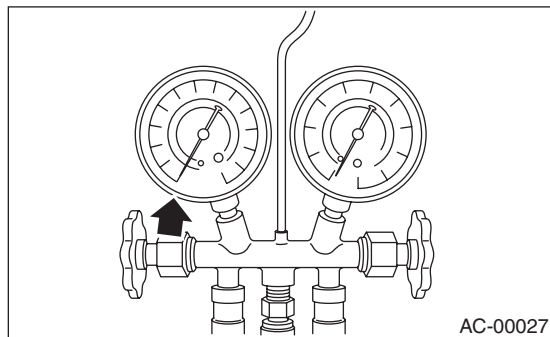

8) Leave it at least 5 minutes, and then check the low-pressure gauge reading for any changes. If the gauge indicator shows near zero point, it is a sign of leakage. Check pipe connector points, repair them, and make sure there is no leakage.

9) Follow the can tap operation manual, install to the refrigerant can.

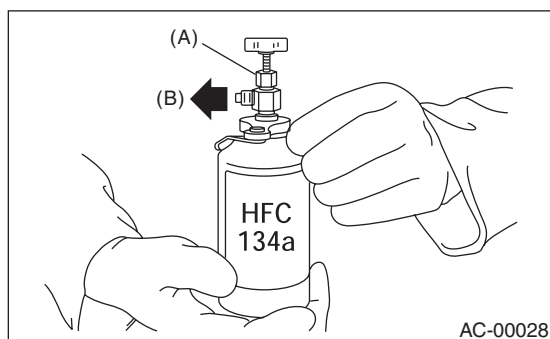

- (A) Tap valve
- (B) Center manifold hose

10) Disconnect the center manifold hose from the vacuum pump, and connect the hose to the tap valve.

11) When a 13.6 kg (30 lb) refrigerant container is used, measure the weight of the refrigerant amount to use using a scale.

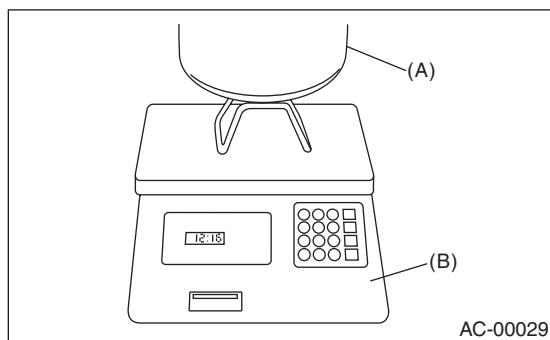

- (A) Refrigerant container (HFC-134a)
- (B) Weight scale

12) Confirm that all the 3 hoses are connected securely to the manifold gauge set.

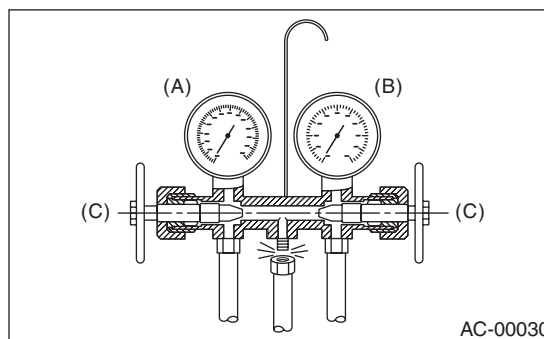

- (A) Low-pressure gauge
(Compound pressure gauge)
- (B) High-pressure gauge
- (C) Close

13) Open the valve on the HFC-134a source.

14) Loosen the center hose connection on the manifold gauge set (if applicable, press a purge valve on the manifold gauge set) for a few seconds to allow the air in the center hose to escape by the refrigerant pressure.

15) Stop the engine and carefully open the high-pressure valve.

CAUTION:
Do not open the low-pressure valve.

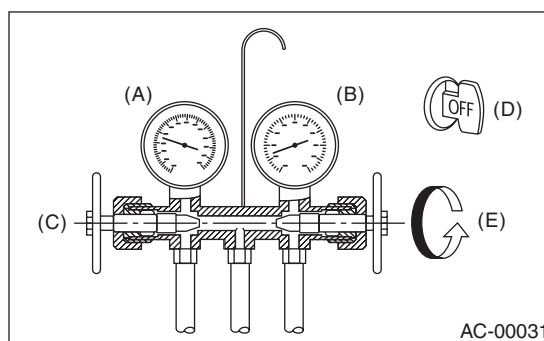

- (A) Low-pressure gauge
(Compound pressure gauge)
- (B) High-pressure gauge
- (C) Close
- (D) Ignition switch OFF
- (E) Slowly open

CAUTION:
Never run the engine while charging from the high-pressure side.

16) Close the high-pressure valve when the low-pressure gauge reaches 98 kPa (1 kg/cm², 14 psi). Using a leak tester, check the system for leaks. If any leakage is found after the refrigerant recovery is completed, repair the applicable area.

Refrigerant Charging Procedure

HVAC SYSTEM (HEATER, VENTILATOR AND A/C)

17) After confirming that there are no leaks with the leak test, charge the required amount of refrigerant.

CAUTION:

Never run the engine while charging from the high-pressure side.

- 18) Close the high-pressure valve when;
- the readings of low- / high-pressure gauges become almost equal, after the charging speed is reduced,
 - the HFC-134a source becomes empty, or the system is full with the gas.

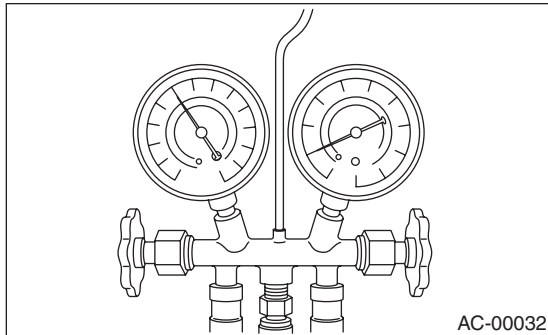

19) If the HFC-134a source is empty, close the high-pressure valve, close the valve on the can tap, and replace the HFC-134a source with a new part to restart the operation.

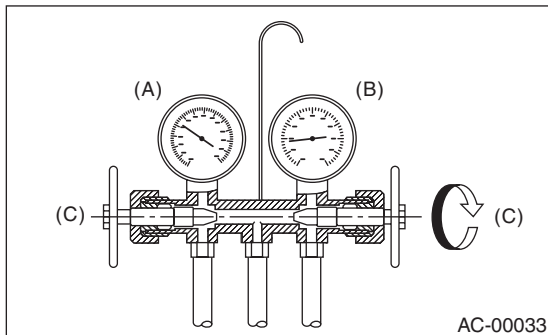

- (A) Low-pressure gauge
(Compound pressure gauge)
- (B) High-pressure gauge
- (C) Close

20) Confirm that both the low- / high-pressure valves can be closed. Start the engine with the A/C switch OFF.

21) Quickly repeat ON-OFF cycles a few times to prevent initial compressor damage.

22) Set up the vehicle to the following status:

- A/C switch ON
- Engine running at 1,500 rpm
- Blower speed setting to "HI"
- Temperature setting to "MAX COOL"
- Air inlet setting to "RECIRC"
- Window open

23) While reading the low-pressure gauge, carefully open the low-pressure valve with the refrigerant source connected and the service hose purged.

CAUTION:

Never open the high-pressure valve with the engine running. The high-pressure gas will back-flow resulting in an explosion of the can.

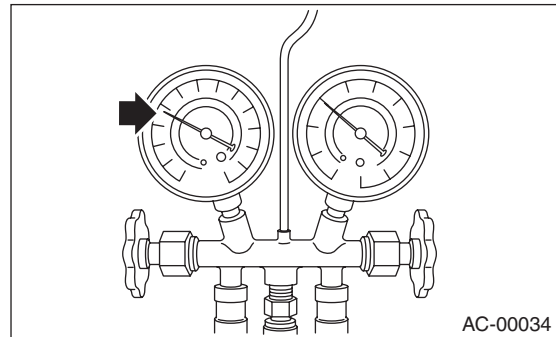

24) Adjust the refrigerant flow to maintain the pressure on the low-pressure side at 276 kPa (2.81 kg/cm², 40 psi) max.

25) After the system is fully charged, close the low-pressure valve.

26) Close the valve on the refrigerant source.

Refrigerant amount		
Refrigerant	Minimum	Maximum
HFC-134a	370 g (0.82 lb)	430 g (0.95 lb)

27) Disconnect the hose from the service port, and install the service port cap.