

## 2. General Description

### A: CAUTION

#### CAUTION:

- The airbag system wiring harnesses and connectors are yellow. Do not use electrical test equipment on these circuits.
- Be careful not to damage the airbag system wiring harness.
- While diagnostic items are being checked, do not operate radios, portable telephones, etc. which emit electromagnetic waves near or inside the vehicle.

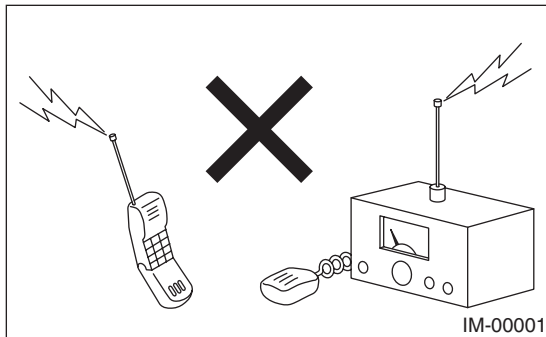

- When turning the ignition switch to ON or OFF while diagnostic items are being checked, do not allow keys with different ID codes close to the ignition switch. If the ignition key is on a key holder, remove it from the key holder before performing diagnoses.

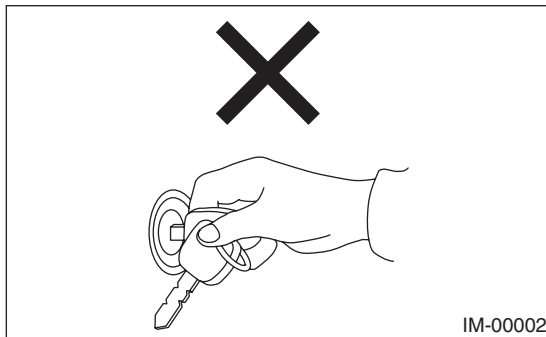

- When repeatedly turning the ignition switch to ON or OFF while diagnostic items are being checked, it should be switched in cycles of "ON" for at least 5 seconds → "OFF" for at least 8 seconds.

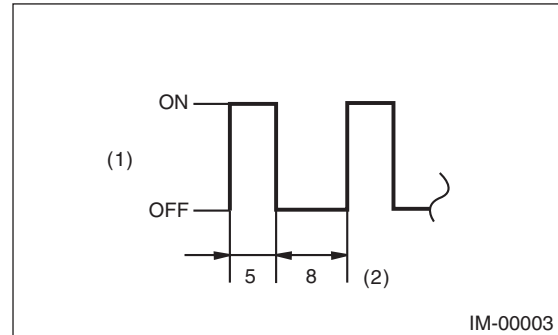

- (1) Ignition switch position
- (2) Sec.



- If the engine fails to start with a registered ignition key, detach the ignition key from ignition switch and wait for approx. 1 second until security indicator light begins to flash. And then start the engine again.
- Before performing the diagnostics, obtain all keys for the vehicle from the owner.
- Do not install or register a body integrated unit already registered to another vehicle to diagnose failures or inspect functions.

# General Description

IMMOBILIZER (DIAGNOSTICS)

## B: PREPARATION TOOL

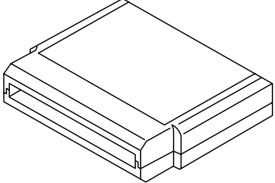
### 1. SPECIAL TOOL

ILLUSTRATION	TOOL NUMBER	DESCRIPTION	REMARKS
 ST18482AA010	18482AA010	CARTRIDGE	Troubleshooting for the electrical system.
 ST22771AA030	22771AA030	SUBARU SELECT MONITOR KIT	Troubleshooting for the electrical system.

### 2. GENERAL TOOL

TOOL NAME	REMARKS
Circuit tester	Used for measuring resistance, voltage and current.