

Diagnostics Chart for Security Indicator Light

IMMOBILIZER (DIAGNOSTICS)

8. Diagnostics Chart for Security Indicator Light

A: INSPECTION

1. CHECK SECURITY INDICATOR LIGHT CIRCUIT

WIRING DIAGRAM:

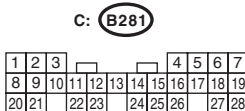
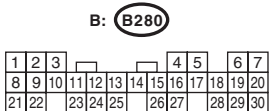
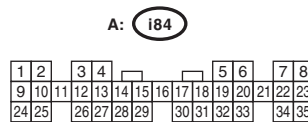
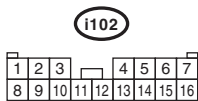
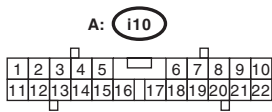
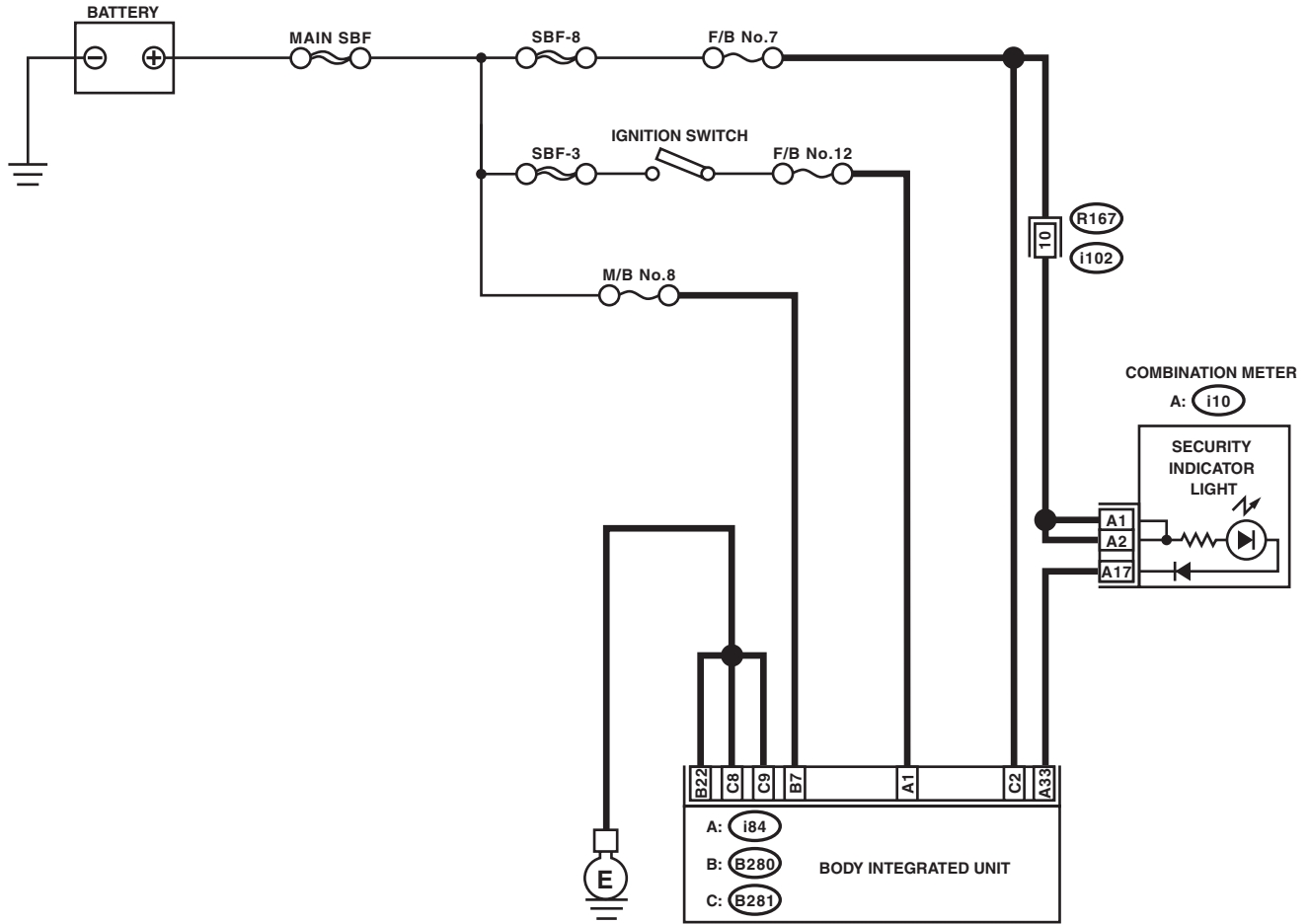

IM-00109

Diagnostics Chart for Security Indicator Light

IMMOBILIZER (DIAGNOSTICS)

| Step | Check | Yes | No |
|---|---|---|---|
| 1 CHECK SECURITY INDICATOR LIGHT. 1) Turn the ignition switch to OFF. 2) Disconnect the harness connector from body integrated unit. 3) Connect the resistor (100 Ω) between the body integrated unit harness connector terminal (i84) No. 33 and chassis ground. | Does the security indicator light illuminate? | Go to step 2. | Go to step 5. |
| 2 CHECK BODY INTEGRATED UNIT GROUND CIRCUIT. Measure the resistance between body integrated unit harness connector terminal and chassis ground. <i>Connector & terminal</i> <i>(B280) No. 22 — Chassis ground:</i> <i>(B281) No. 8, No. 9 — Chassis ground:</i> | Is the resistance less than 10 Ω? | Go to step 3. | Repair the open circuit of body integrated unit ground circuit. |
| 3 CHECK BODY INTEGRATED UNIT IGNITION CIRCUIT. 1) Turn the ignition switch to ON. (Engine OFF) 2) Measure the voltage between body integrated unit harness connector terminal and chassis ground. <i>Connector & terminal</i> <i>(i84) No. 1 (+) — Chassis ground (-):</i> | Is the voltage more than 10 V? | Go to step 4. | Check the harness for open or short circuit between body integrated unit and ignition switch. |
| 4 CHECK BODY INTEGRATED UNIT POWER SUPPLY CIRCUIT. 1) Turn the ignition switch to OFF. 2) Measure the voltage between body integrated unit harness connector terminal and chassis ground. <i>Connector & terminal</i> <i>(B280) No. 7 (+) — Chassis ground (-):</i> <i>(B281) No. 2 (+) — Chassis ground (-):</i> | Is the voltage more than 10 V? | Replace the body integrated unit <Ref. to SL-55, Body Integrated Unit.> and replace all the ignition keys (including transponder). Execute the registration procedure next. Refer to the "REGISTRATION MANUAL FOR IMMOBILIZER". | Check the harness for open or short circuits between the body integrated unit and fuse. |
| 5 CHECK COMBINATION METER CIRCUIT. 1) Remove the combination meter. <Ref. to IDI-14, Combination Meter.> 2) Measure the voltage between combination meter harness connector terminal and chassis ground. <i>Connector & terminal</i> <i>(i10) No. 1, No. 2 (+) — Chassis ground (-):</i> | Is the voltage more than 10 V? | Go to step 6. | Check the harness for open or short between combination meter and fuse. |
| 6 CHECK COMBINATION METER CIRCUIT. Measure the resistance between the body integrated unit harness connector terminal and combination meter harness connector terminal. <i>Connector & terminal</i> <i>(i84) No. 33 — (i10) No. 17:</i> | Is the resistance less than 10 Ω? | LED bulb malfunction. Replace the combination meter assembly. <Ref. to IDI-15, DISASSEMBLY, Combination Meter.> | Repair the harness or connector. |

Diagnostics Chart for Security Indicator Light

IMMOBILIZER (DIAGNOSTICS)

2. CHECK KEY SWITCH CIRCUIT

WIRING DIAGRAM:

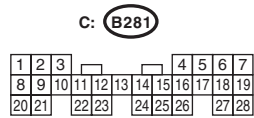
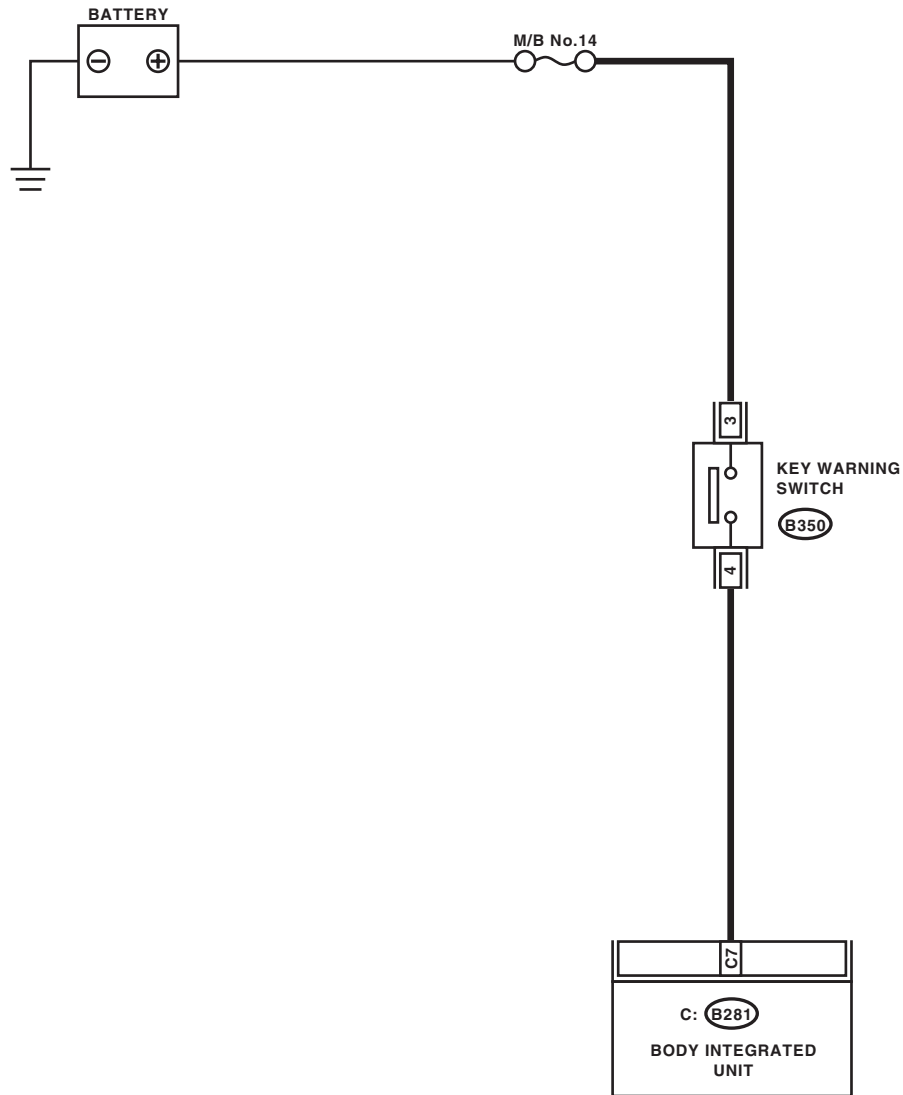

IM-00078

Diagnostics Chart for Security Indicator Light

IMMOBILIZER (DIAGNOSTICS)

| Step | Check | Yes | No |
|---|--|---|---|
| 1 CHECK POWER SUPPLY CIRCUIT. 1) Disconnect the harness connector from key warning switch. 2) Turn the ignition switch to "ACC" or "LOCK" (with key inserted). 3) Measure the voltage between key warning switch harness connector terminal and chassis ground. <i>Connector & terminal</i> <i>(B350) No. 3 (+) — Chassis ground (-):</i> | Is the voltage more than 10 V? | Go to step 2. | Check the harness for an open or short between the key warning switch and fuse. |
| 2 CHECK KEY WARNING SWITCH. 1) Insert the ignition key into the ignition switch. (OFF or ACC) 2) Measure the resistance between key warning switch connector terminals. <i>Connector & terminal</i> <i>No. 3 — No. 4:</i> | Is the resistance less than 1 Ω ? | Go to step 3. | Replace the key warning switch. |
| 3 CHECK KEY WARNING SWITCH. 1) Remove the ignition key from the ignition switch. 2) Measure the resistance between key warning switch connector terminals. <i>Connector & terminal</i> <i>No. 3 — No. 4:</i> | Is the resistance more than 1 M Ω ? | Go to step 4. | Replace the key warning switch. |
| 4 CHECK HARNESS BETWEEN KEY WARNING SWITCH AND BODY INTEGRATED UNIT. 1) Disconnect the harness connector from key warning switch. 2) Disconnect the harness connector from body integrated unit. 3) Measure the resistance between key warning switch harness connector terminal and body integrated unit harness connector terminal. <i>Connector & terminal</i> <i>(B350) No. 4 — (B281) No. 7:</i> | Is the resistance less than 10 Ω ? | Replace the body integrated unit <Ref. to SL-55, Body Integrated Unit.> and replace all the ignition keys (including transponder). Execute the registration procedure next. Refer to the "REGISTRATION MANUAL FOR IMMOBILIZER". | Repair the harness between key warning switch and body integrated unit. |