

Combination Base Switch Assembly

LIGHTING SYSTEM

9. Combination Base Switch Assembly

A: REMOVAL

- 1) Remove the driver's airbag module. <Ref. to AB-17, REMOVAL, Driver's Airbag Module.>
- 2) Remove the steering wheel. <Ref. to PS-14, REMOVAL, Steering Wheel.>
- 3) Remove the screws and remove the steering column lower cover.

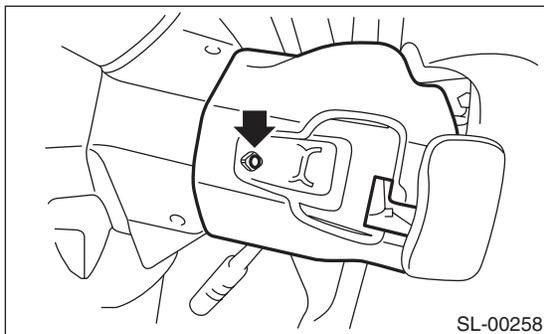

- 4) Remove the combination switch. <Ref. to LI-9, REMOVAL, Combination Switch (Light).> <Ref. to WW-6, REMOVAL, Combination Switch (Wiper).>
- 5) Remove the four screws and remove the roll connector.
- 6) Remove the three screws.

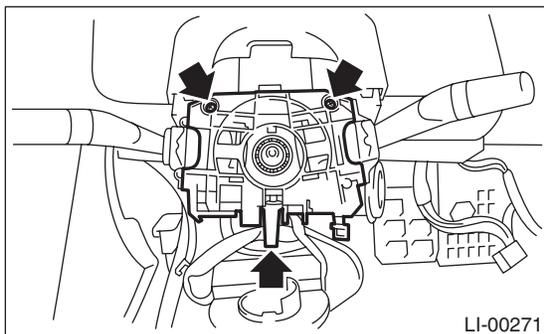

- 7) Disconnect the connector and remove the combination base switch assembly.

B: INSTALLATION

- 1) Install in the reverse order of removal.
- 2) Before installing the steering wheel, be sure to adjust the direction of roll connector with steering. <Ref. to AB-26, ADJUSTMENT, Roll Connector.>

C: INSPECTION

1. COMBINATION BASE SWITCH ASSEMBLY

Inspect the combination base switch assembly and roll connector for cracks or deformation. If any damage is found, replace with a new part.

2. PARKING SWITCH

Measure the resistance between parking switch terminals.

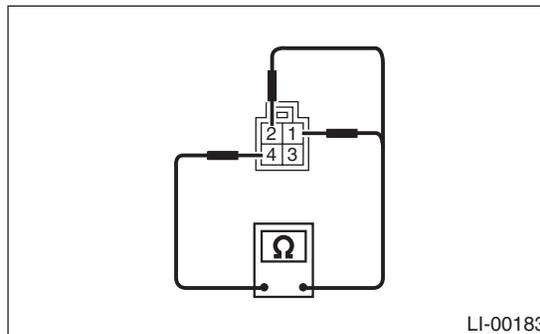

Switch position	Terminal No.	Standard
OFF	2 and 4	Less than 1 Ω
ON	1 and 4	Less than 1 Ω