

## 26. Interior Light System

### A: WIRING DIAGRAM

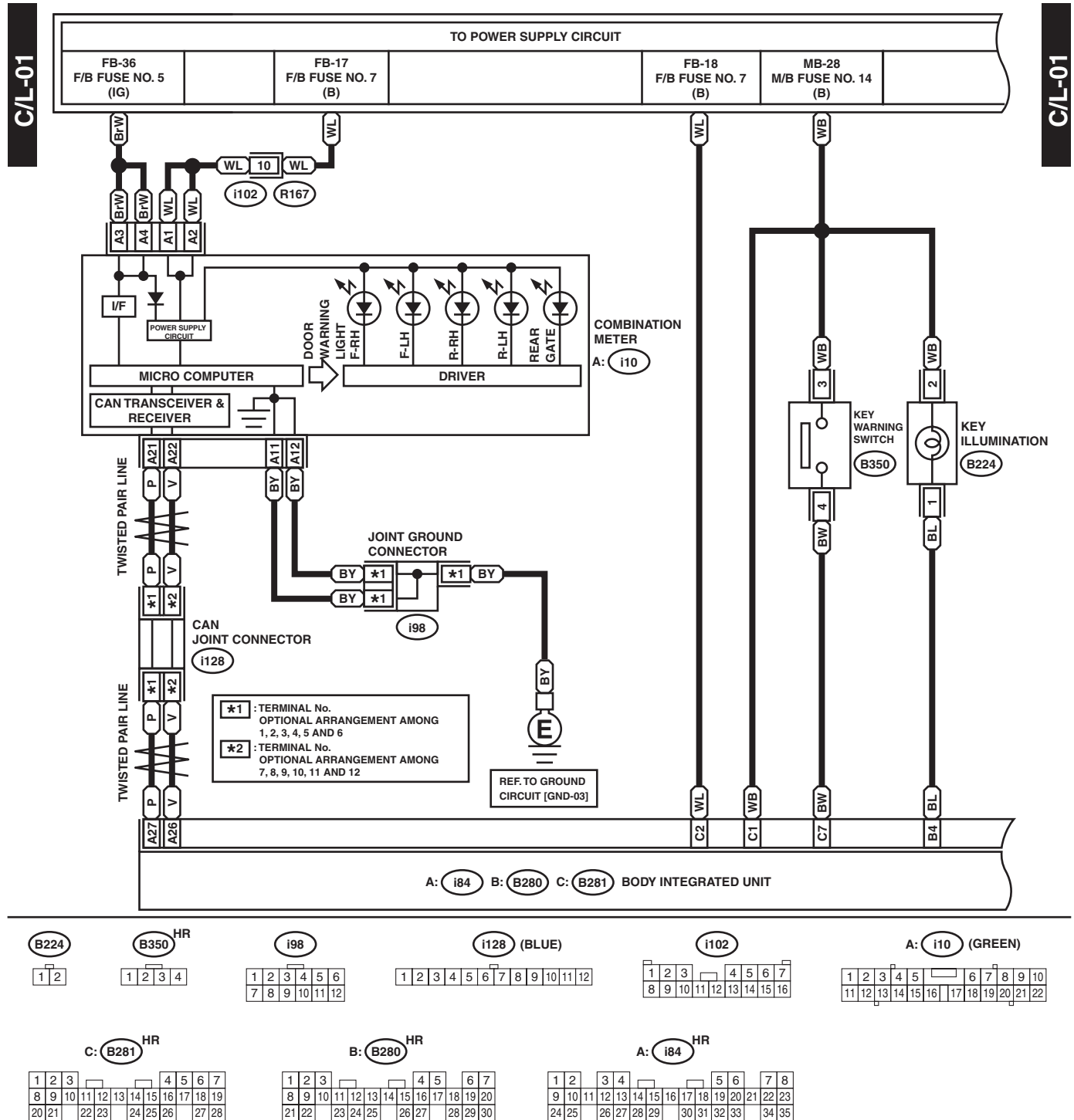

# Interior Light System

WIRING SYSTEM

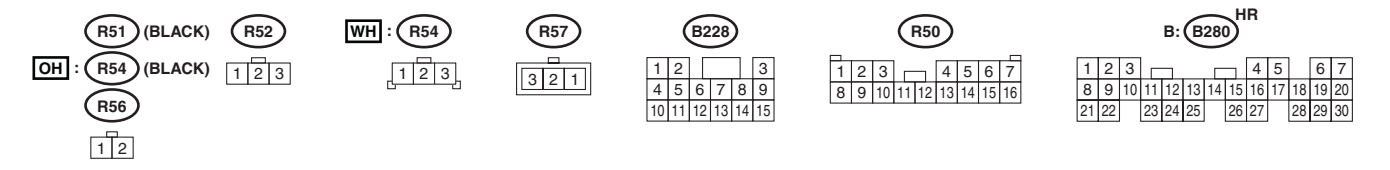
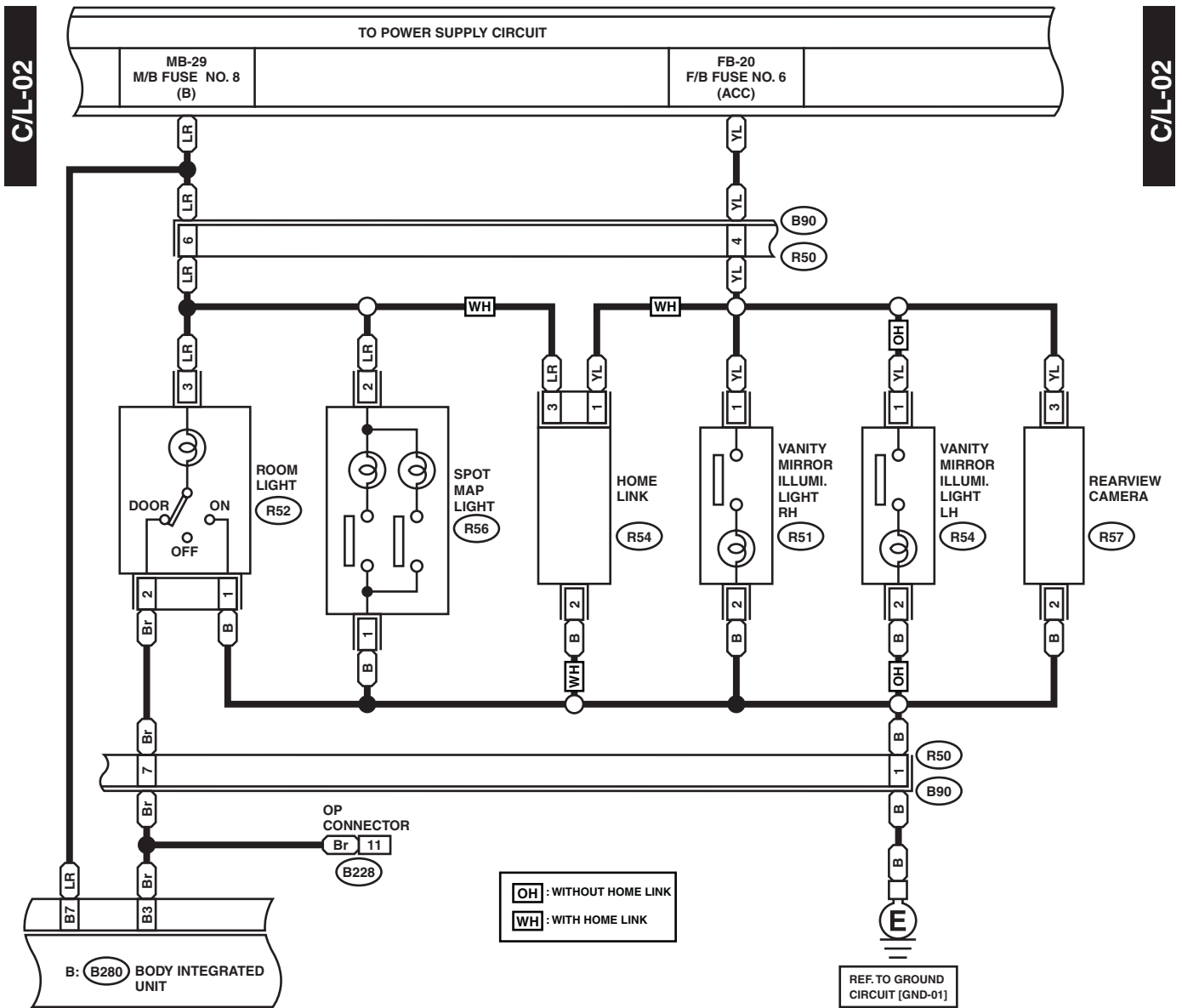

WI-11953

# Interior Light System

WIRING SYSTEM

C/L-03

C/L-03

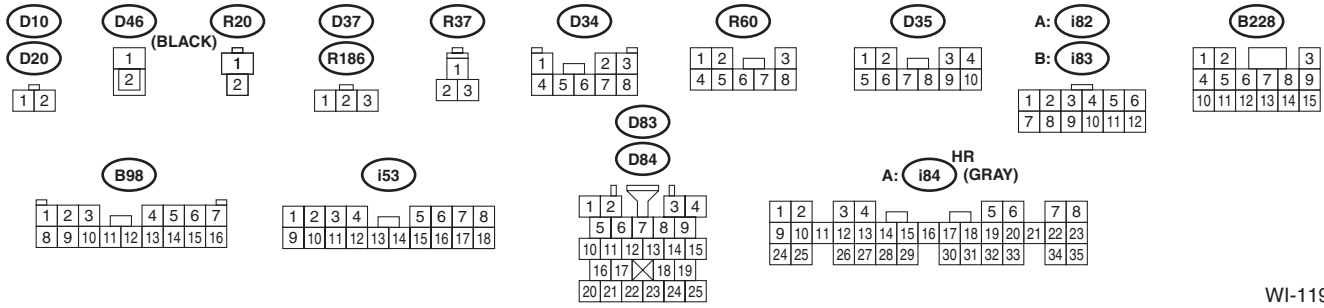
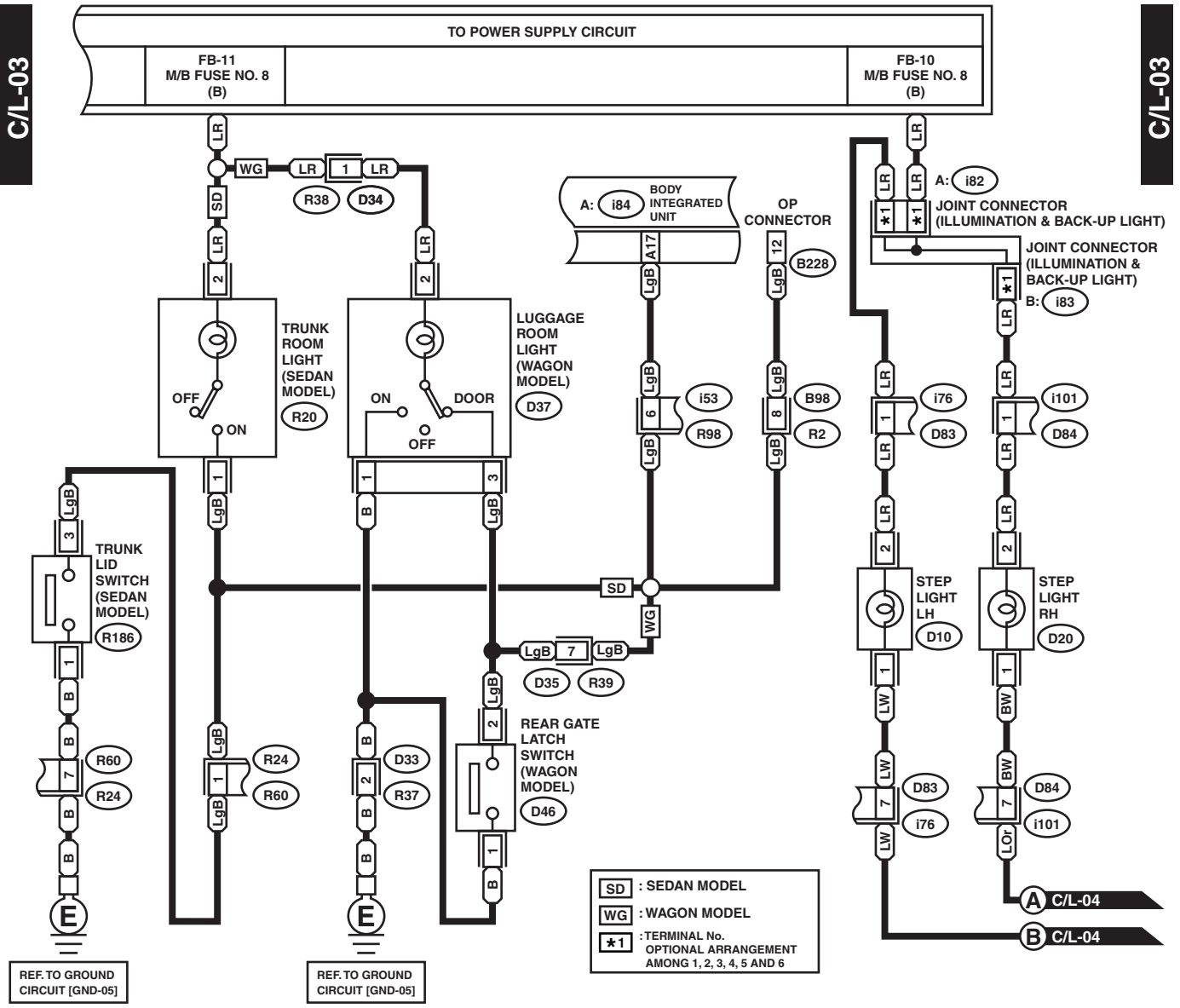

WI-11954

# Interior Light System

WIRING SYSTEM

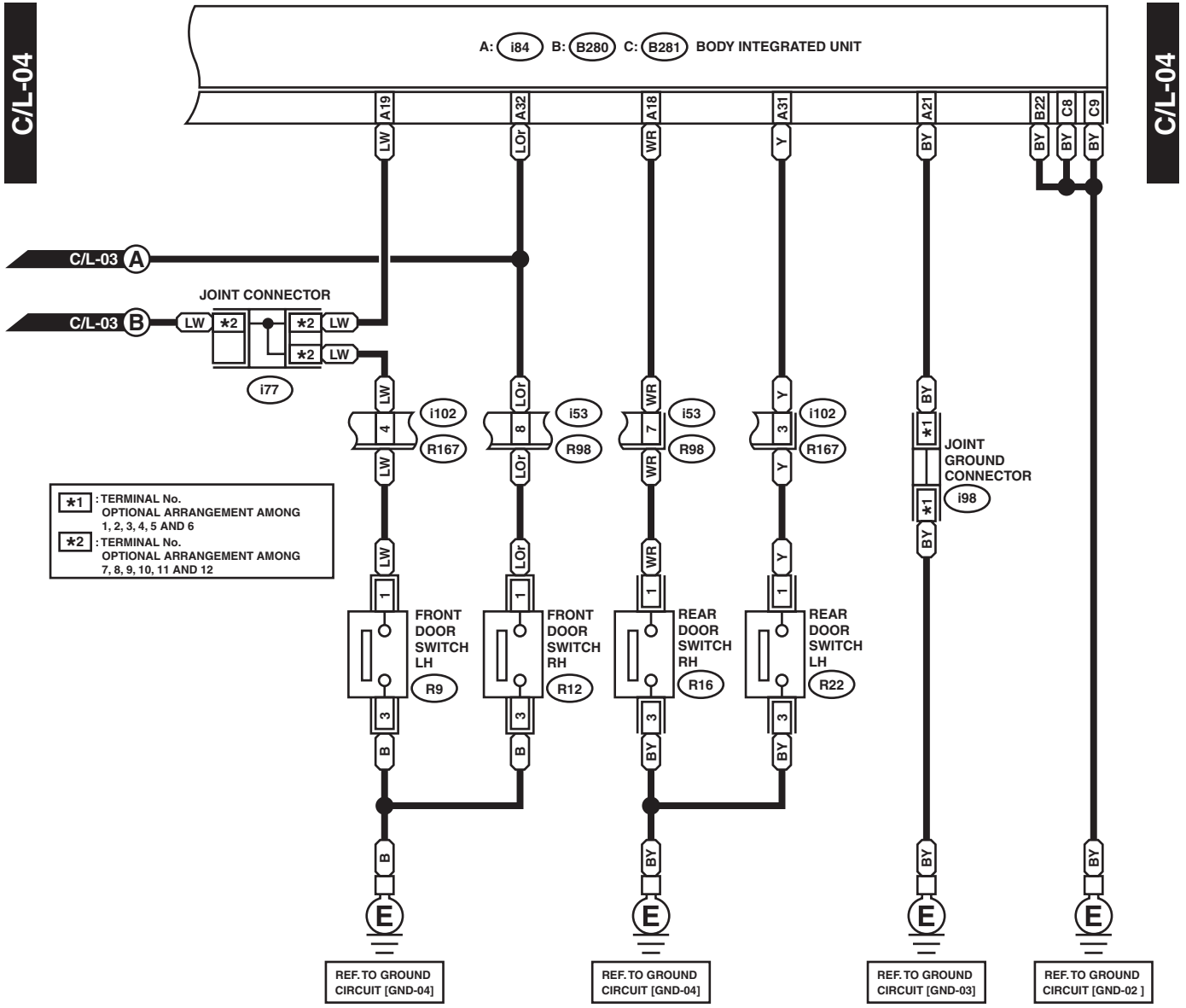

★1 : TERMINAL No. OPTIONAL ARRANGEMENT AMONG 1, 2, 3, 4, 5 AND 6  
 ★2 : TERMINAL No. OPTIONAL ARRANGEMENT AMONG 7, 8, 9, 10, 11 AND 12

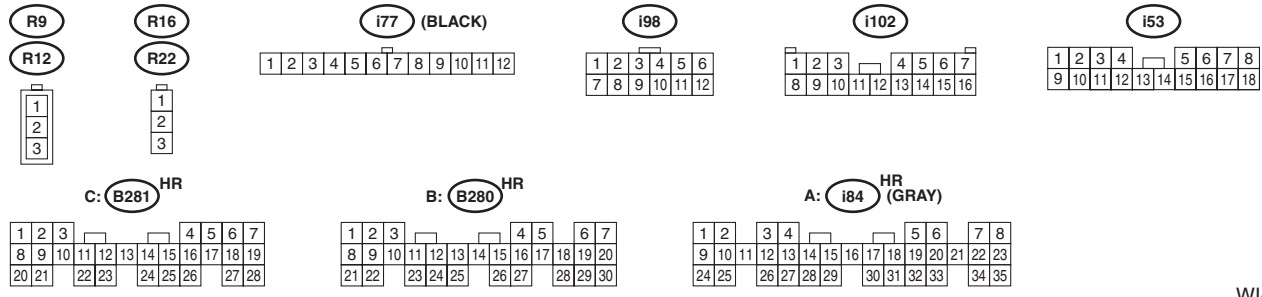

WI-11955