

3. Power Supply Circuit

A: WIRING DIAGRAM

P-SUP-01

P-SUP-01

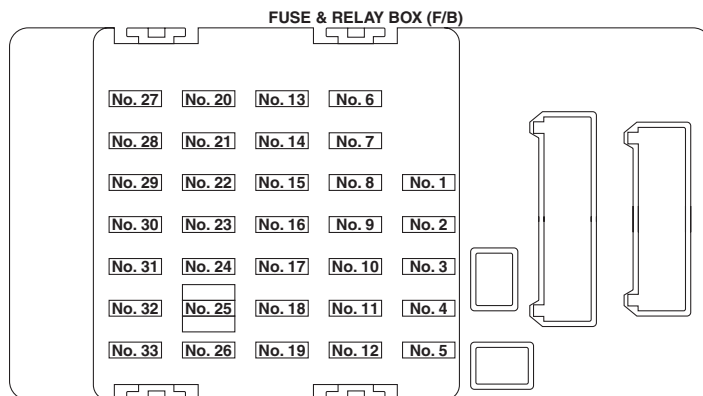
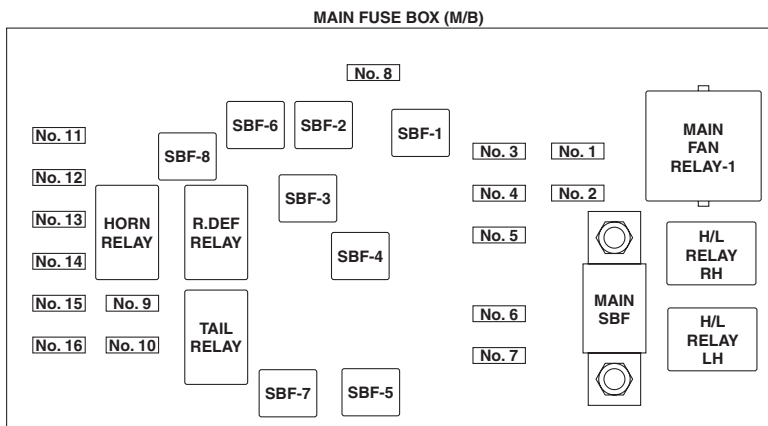

Power Supply Circuit

WIRING SYSTEM

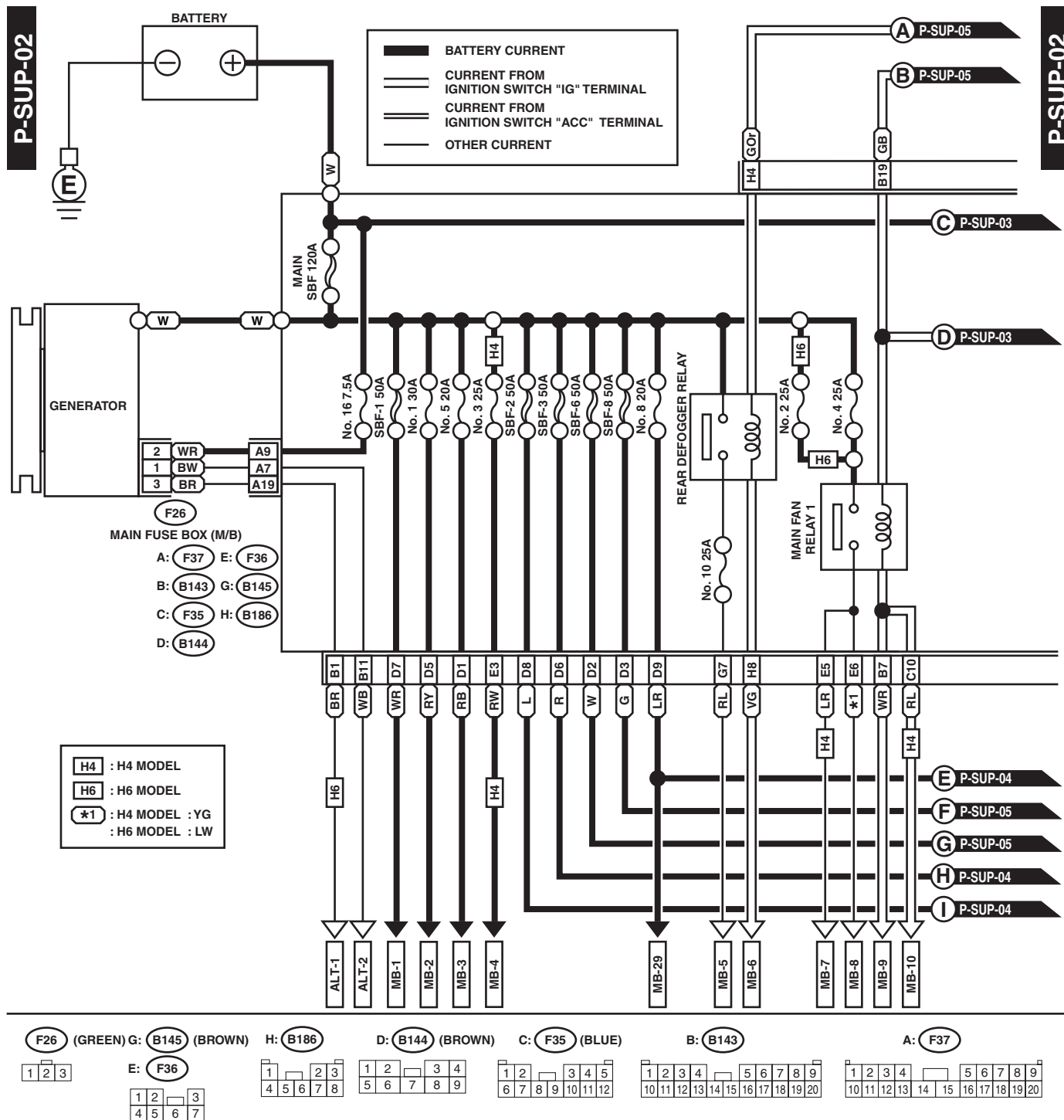

WI-09687

Power Supply Circuit

WIRING SYSTEM

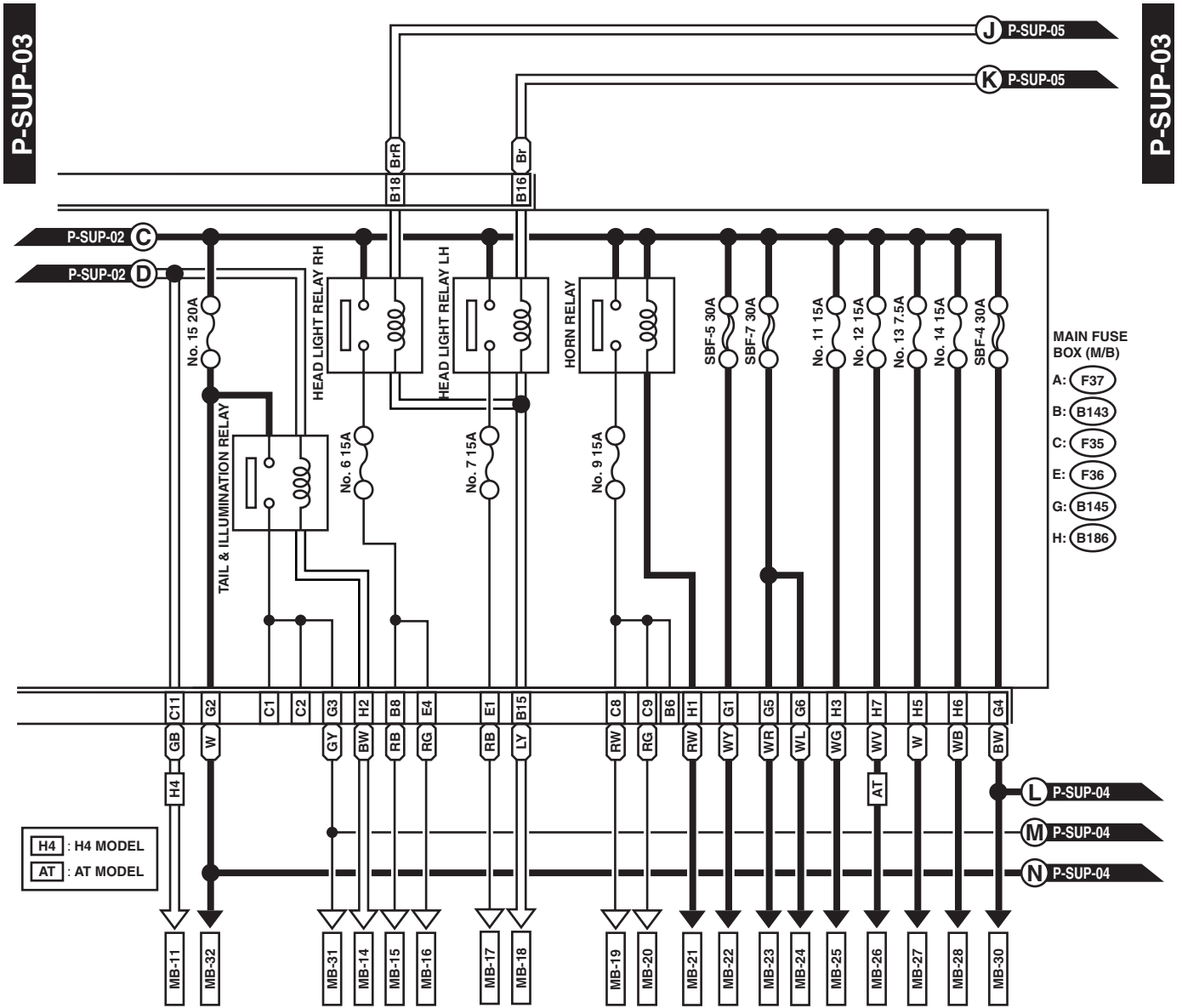

- MAIN FUSE BOX (M/B)
- A: (F37)
 - B: (B143)
 - C: (F35)
 - E: (F36)
 - G: (B145)
 - H: (B186)

- G: (B145) (BROWN)
- E: (F36)
- | | | | |
|---|---|---|---|
| 1 | 2 | 3 | |
| 4 | 5 | 6 | 7 |

- H: (B186)
- | | | | | |
|---|---|---|---|---|
| 1 | 2 | 3 | | |
| 4 | 5 | 6 | 7 | 8 |

- C: (F35) (BLUE)
- | | | | | | | |
|---|---|---|---|----|----|----|
| 1 | 2 | 3 | 4 | 5 | | |
| 6 | 7 | 8 | 9 | 10 | 11 | 12 |

- B: (B143)
- | | | | | | | | | | | |
|----|----|----|----|----|----|----|----|----|----|----|
| 1 | 2 | 3 | 4 | 5 | 6 | 7 | 8 | 9 | | |
| 10 | 11 | 12 | 13 | 14 | 15 | 16 | 17 | 18 | 19 | 20 |

- A: (F37)
- | | | | | | | | | | | |
|----|----|----|----|----|----|----|----|----|----|----|
| 1 | 2 | 3 | 4 | 5 | 6 | 7 | 8 | 9 | | |
| 10 | 11 | 12 | 13 | 14 | 15 | 16 | 17 | 18 | 19 | 20 |

H4 : H4 MODEL
AT : AT MODEL

WI-09688

Power Supply Circuit

WIRING SYSTEM

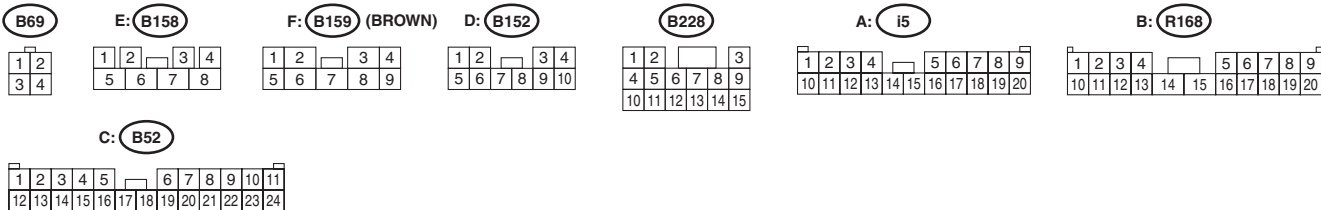
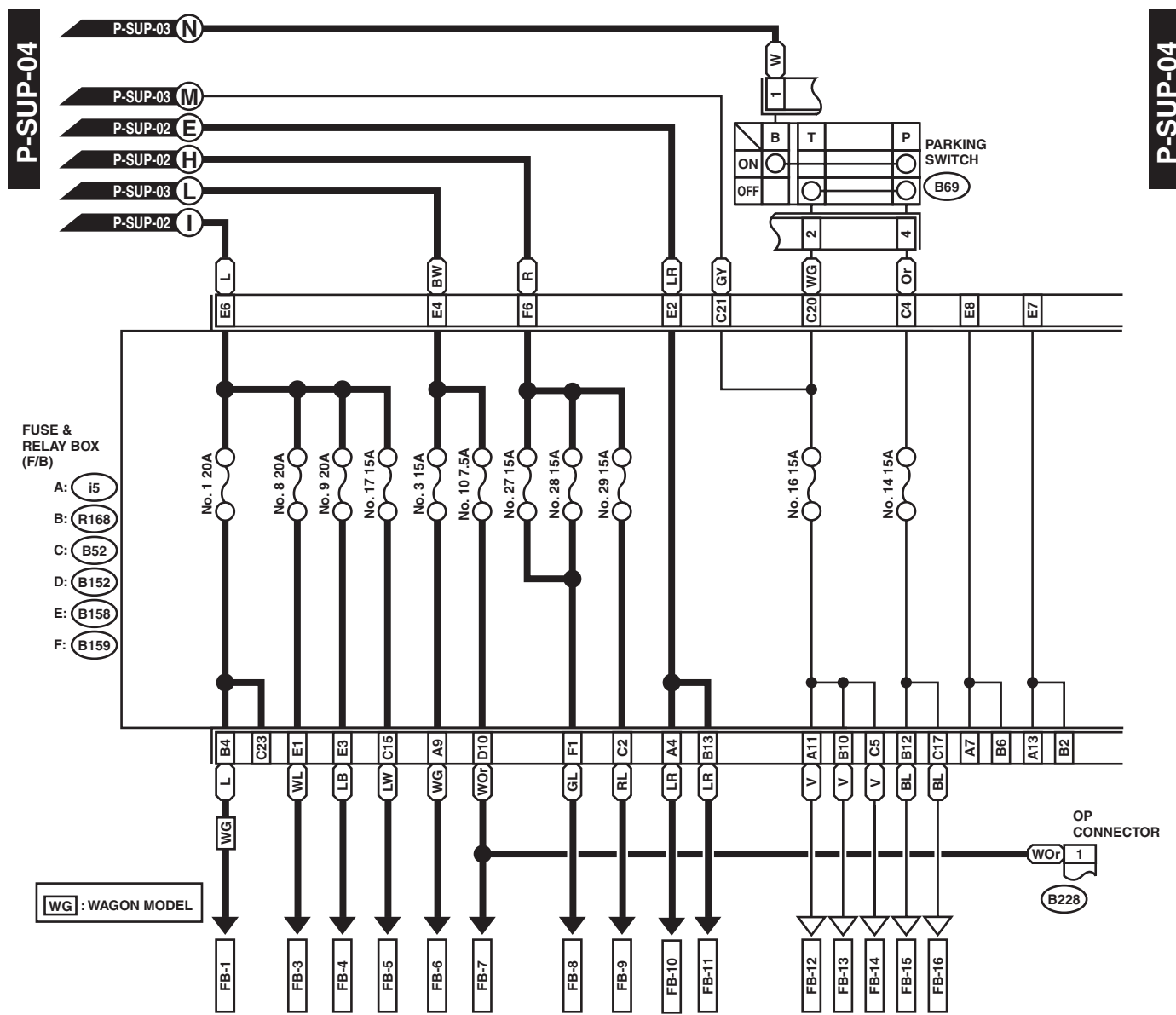

WI-09689

Power Supply Circuit

WIRING SYSTEM

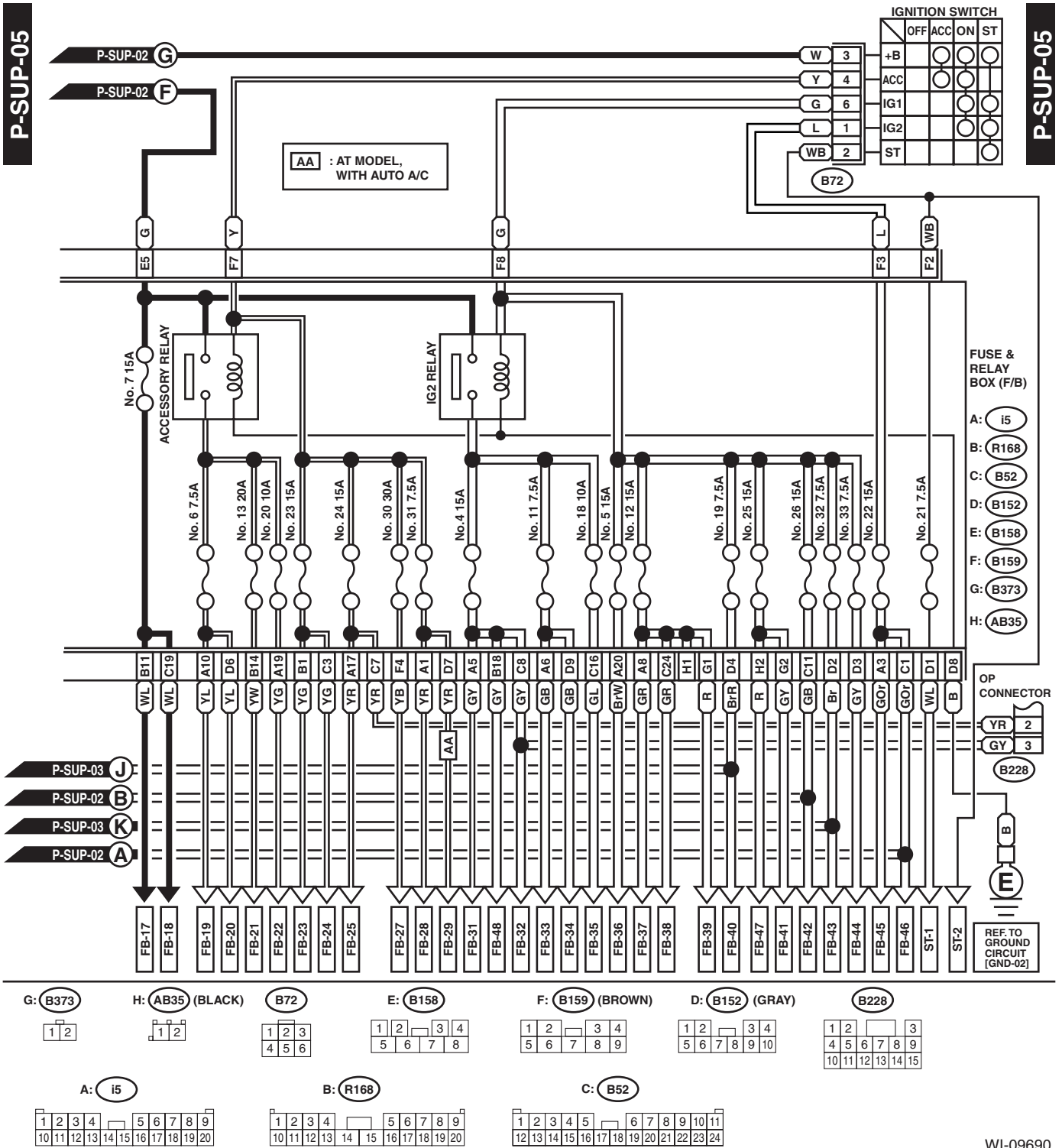

WI-09690

Power Supply Circuit

WIRING SYSTEM

| No. | Load |
|-------|---|
| MB-1 | ABS control module VDC control module |
| MB-2 | ABS control module VDC control module |
| MB-4 | Sub fan relay |
| MB-5 | A/C control panel Mirror heater relay Rear defogger |
| MB-6 | Body integrated unit |
| MB-7 | Main fan relay 2 |
| MB-8 | PWM controller Main fan motor |
| MB-9 | ECM |
| MB-10 | Main fan relay 2 |
| MB-11 | Main fan relay 2 |
| MB-14 | OP connector Lighting switch |
| MB-15 | Combination meter |
| MB-16 | Headlight RH |
| MB-17 | Headlight LH |
| MB-18 | OP connector Daytime running light control module |
| MB-19 | Horn (HI) |
| MB-20 | Horn (LO) |
| MB-21 | Horn switch Body integrated unit |
| MB-22 | Oxygen sensor relay Main relay |
| MB-23 | Oxygen sensor relay Main relay |
| MB-24 | Electronic throttle control relay |
| MB-25 | Fuel pump relay |
| MB-26 | TCM |
| MB-27 | ECM Data link connector |
| MB-28 | Key warning switch Key illumination Key actuator Turn signal and hazard unit Body integrated unit |
| MB-29 | Auto A/C control module Spot map light Body integrated unit Home link Room light |
| MB-30 | Power window circuit breaker |
| MB-31 | F/B fuse No. 16 |
| MB-32 | Parking light switch |
| ALT-1 | ECM |
| ST-1 | ECM Starter relay Clutch switch (MT model) |
| ST-2 | Starter relay |
| FB-1 | Trailer connector |
| FB-3 | Stop light & brake switch |

| No. | Load |
|-------|---|
| FB-4 | Mirror heater relay Wiper deicer relay |
| FB-5 | Seat heater relay |
| FB-6 | Body integrated unit |
| FB-7 | OP connector |
| FB-8 | Blower fan relay |
| FB-9 | Front fog light relay |
| FB-10 | Audio Keyless entry control module Step light LH Step light RH Clock TV monitor |
| FB-11 | Trunk room light (Sedan model) Navigation control module Luggage room light (Wagon model) |
| FB-12 | Clock TV monitor |
| FB-13 | Navigation control module Seat heater switch |
| FB-14 | OP connector Lighting switch |
| FB-17 | TPM control module Impact sensor Combination meter |
| FB-18 | Body integrated unit |
| FB-19 | Remote control mirror switch |
| FB-20 | Seat heater relay Vanity mirror illumination LH Vanity mirror illumination RH |
| FB-21 | Front accessory power supply socket Rear accessory power supply socket |
| FB-22 | Front accessory power supply socket |
| FB-23 | Rear wiper motor |
| FB-24 | Body integrated unit Rear washer motor |
| FB-25 | Audio Navigation control module Clock TV monitor |
| FB-27 | Front washer motor Front wiper switch Front wiper motor |
| FB-28 | Body integrated unit |
| FB-29 | TCM Auto A/C control module |
| FB-31 | TV monitor |
| FB-32 | ECM OP connector Clutch switch (MT/Cruise) Sunroof control unit Open/close and tilt switch Seat belt warning light Data link connector Line end check connector Wiper deicer relay Stop light and brake switch |

Power Supply Circuit

WIRING SYSTEM

| No. | Load |
|-------|--|
| FB-33 | Clock |
| FB-34 | Turn signal and hazard unit |
| FB-35 | Inhibitor switch (4AT model) Daytime running light control module Back-up light switch (MT model) Back-up light relay (5AT model) |
| FB-36 | Combination meter |
| FB-37 | Body integrated unit |
| FB-38 | ECM P-VIGN relay (5AT model) TCM Ignition coil Fuel pump relay Rear vehicle speed sensor (4AT model) |
| FB-39 | Airbag control module |
| FB-41 | Airbag control module |
| FB-42 | Power window relay |
| FB-44 | ABS control module VDC control module |
| FB-45 | A/C control panel |
| FB-46 | A/C relay FRESH/RECIRC actuator Auto A/C control module Sub fan relay Pressure switch Blower fan relay |
| FB-47 | Occupant detection control module |
| FB-48 | TPM control module Impact sensor |