

2.2L 4-CYL & 2.2L 4-CYL TURBO - VIN [6]

Article Text

1992 Subaru Legacy

For Canadian Tire 777 Niagara Street, Welland Ontario (905) 732-7501 Ext. 325

Copyright © 1997 Mitchell International

Saturday, February 20, 1999 04:12PM

ARTICLE BEGINNING

1992 SUBARU ENGINES
2.2L & 2.2L Turbo 4-Cylinder

Legacy

* PLEASE READ THIS FIRST *

NOTE: For engine repair procedures not covered in this article, see ENGINE OVERHAUL PROCEDURES - GENERAL INFORMATION article in the GENERAL INFORMATION section.

ENGINE IDENTIFICATION

Engine can be identified by 6th character of Vehicle Identification Number (VIN). Legacy Turbo models have a "7" as the 7th digit of the VIN.

The VIN is stamped on a metal plate located on front right side of firewall. Identification number of engine is stamped on a machined pad on right front of engine cylinder block.

ENGINE IDENTIFICATION CODES TABLE

Application	(1) VIN Code
Legacy	
2.2L 4-Cylinder	6

(1) - Legacy turbo models have a "7" as the 7th character of the VIN.

ADJUSTMENTS

VALVE CLEARANCE ADJUSTMENT

Engine has hydraulic lifters. Valve adjustment is not required.

REMOVAL & INSTALLATION

NOTE: For reassembly reference, label all electrical connectors, vacuum hoses and fuel lines before removal. Also place mating marks on engine hood and other major assemblies before removal.

FUEL PRESSURE RELEASE

To release fuel pressure, disconnect fuel pump wiring

2.2L 4-CYL & 2.2L 4-CYL TURBO - VIN [6]

Article Text (p. 2)

1992 Subaru Legacy

For Canadian Tire 777 Niagara Street, Welland Ontario (905) 732-7501 Ext. 325

Copyright © 1997 Mitchell International

Saturday, February 20, 1999 04:12PM

connector. Start engine, and operate it until it stalls. Crank engine for an additional 5 seconds. With ignition off, reconnect fuel pump wiring connector.

ENGINE

NOTE: Removal procedure leaves transaxle in vehicle.

Removal

1) Release fuel pressure. See FUEL PRESSURE RELEASE. Drain cooling system. Disconnect battery cable, and remove battery. Disconnect upper and lower radiator and heater hoses. Remove radiator. Disconnect electrical connectors, vacuum hoses and fuel lines.

NOTE: Discharge A/C system using approved refrigerant recovery/recycling equipment.

2) Disconnect accelerator cable, cruise control cable (if equipped) and hill holder cable (M/T models) at clutch release fork. Remove accessory drive belts. Remove power steering pump with hoses attached. Discharge A/C system, and disconnect hoses.

3) Remove center exhaust pipe and heat shield. Remove air cleaner case and hoses. Disconnect engine mount from front crossmember. Remove nuts attaching lower engine to transaxle. Remove timing hole cover.

4) Disconnect drive plate from torque converter. Remove engine torque rod. Support engine using hoist. Support transaxle using floor jack. Remove bolts attaching upper side of engine to transmission. Remove engine.

Installation

To install, reverse removal procedure. Adjust all control cables. Check all fluid levels.

INTAKE MANIFOLD

NOTE: Fuel pressure must be released if fuel lines or fuel system components are removed. See FUEL PRESSURE RELEASE.

Removal & Installation

Release fuel pressure. See FUEL PRESSURE RELEASE. Remove "V" belt. Remove power steering pump. Remove alternator and bracket. Disconnect PCV and blow-by hoses. Disconnect spark plug caps. Remove crank angle and cam angle sensors. Disconnect oil pressure switch connector. Remove knock sensor. Remove intake manifold. To install, reverse removal procedure. Replace all "O" rings.

EXHAUST MANIFOLD

NOTE: Exhaust manifold is integral with cylinder head.

CYLINDER HEAD

2.2L 4-CYL & 2.2L 4-CYL TURBO - VIN [6]

Article Text (p. 3)

1992 Subaru Legacy

For Canadian Tire 777 Niagara Street, Welland Ontario (905) 732-7501 Ext. 325

Copyright © 1997 Mitchell International

Saturday, February 20, 1999 04:12PM

Removal

Drain coolant. Remove timing belts and camshaft sprocket. See TIMING BELT. Remove intake manifold and exhaust pipe. Remove cylinder head bolts in reverse order of tightening sequence. See Fig. 1. Remove cylinder head and gasket.

Inspection

Check cylinder head warpage and height. Resurface head if warpage exceeds specification. See CYLINDER HEAD table under ENGINE SPECIFICATIONS at end of article. Replace cylinder head if it is not within specification after resurfacing.

Installation

1) Ensure mating surfaces are clean and dry. Install head gasket. Coat head bolt threads with oil. Tighten bolts to specification using proper sequence. See Fig. 1. See TORQUE SPECIFICATIONS table at end of article.

2) To install remaining components, reverse removal procedure. Tighten bolts to specification. See TORQUE SPECIFICATIONS table.

CAUTION: After initial start-up, recheck cylinder head bolt torque after running engine at normal operating temperature. Retighten head bolts when engine is dead COLD.

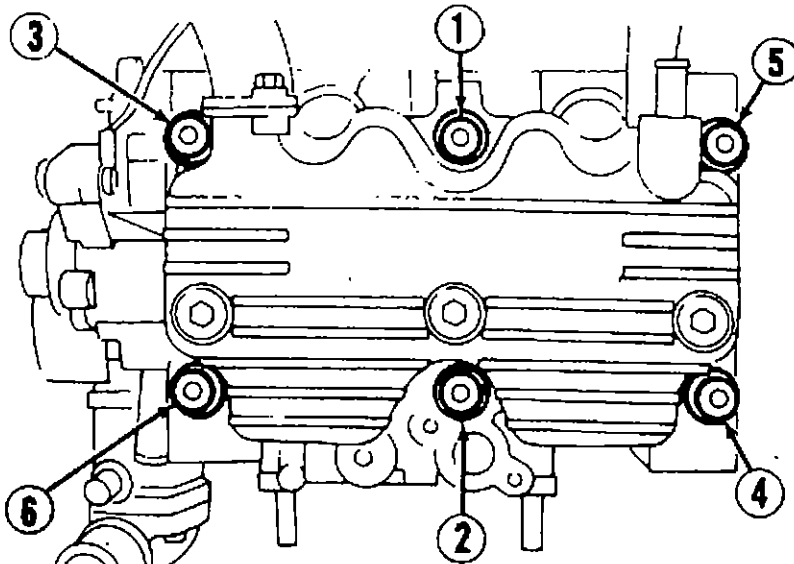

Fig. 1: Cylinder Head Bolt Tightening Sequence
Courtesy of Subaru of America, Inc.

TIMING BELT R & I

Removal

1) Remove alternator drive belt. Remove crankshaft pulley bolt. Remove crankshaft pulley. If engine is removed from vehicle, crankshaft can be held using Flywheel Stopper (498277000) for M/T

2.2L 4-CYL & 2.2L 4-CYL TURBO - VIN [6]

Article Text (p. 4)

1992 Subaru Legacy

For Canadian Tire 777 Niagara Street, Welland Ontario (905) 732-7501 Ext. 325

Copyright © 1997 Mitchell International

Saturday, February 20, 1999 04:12PM

models or Drive Plate Stopper (498497000) for A/T models.

2) Remove front, left and right timing belt covers. See Fig. 2. If timing belt is to be reused, mark belt to indicate original direction of rotation before removal. Use Crankshaft Socket (499987500) to turn crankshaft pulley.

3) Align crankshaft and camshaft timing notches with corresponding notches on timing cover and engine block. See Fig. 3. Use White paint to mark timing belt in relation to sprocket timing marks. See Fig. 4. Loosen tensioner adjuster mounting bolts. Remove belt idler. Remove belt idler No. 2. Remove timing belt.

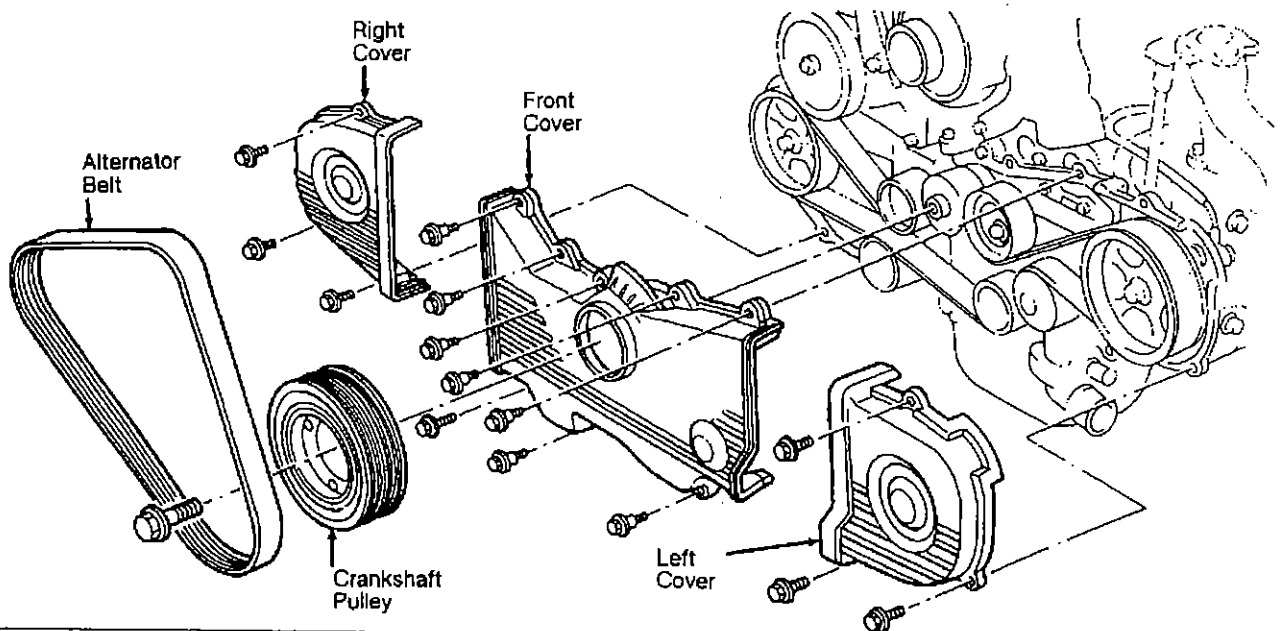

Fig. 2: Removing Front, Right & Left Timing Belt Covers
Courtesy of Subaru of America, Inc.

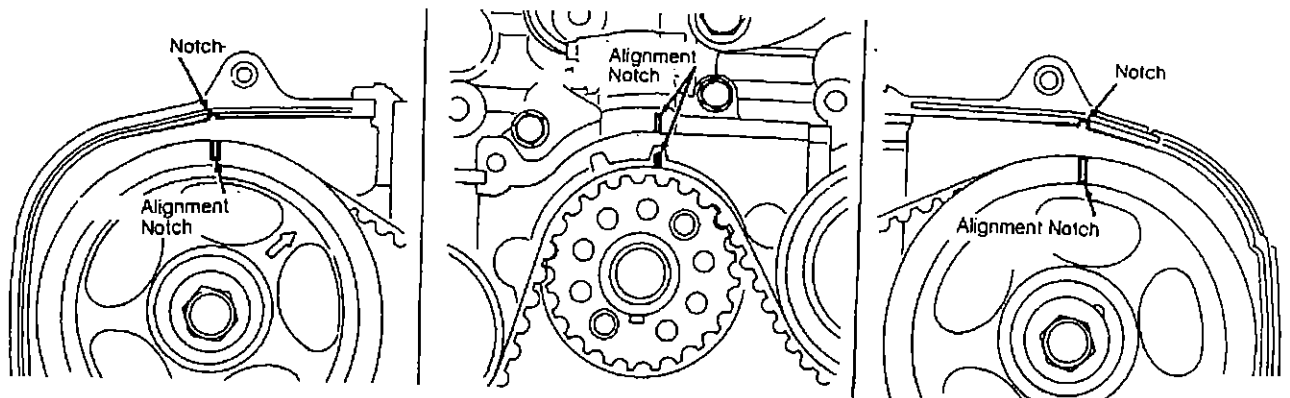

Fig. 3: Aligning Camshaft & Crankshaft Pulley Timing Marks
Courtesy of Subaru of America, Inc.

2.2L 4-CYL & 2.2L 4-CYL TURBO - VIN [6]

Article Text (p. 5)

1992 Subaru Legacy

For Canadian Tire 777 Niagara Street, Welland Ontario (905) 732-7501 Ext. 325

Copyright © 1997 Mitchell International

Saturday, February 20, 1999 04:12PM

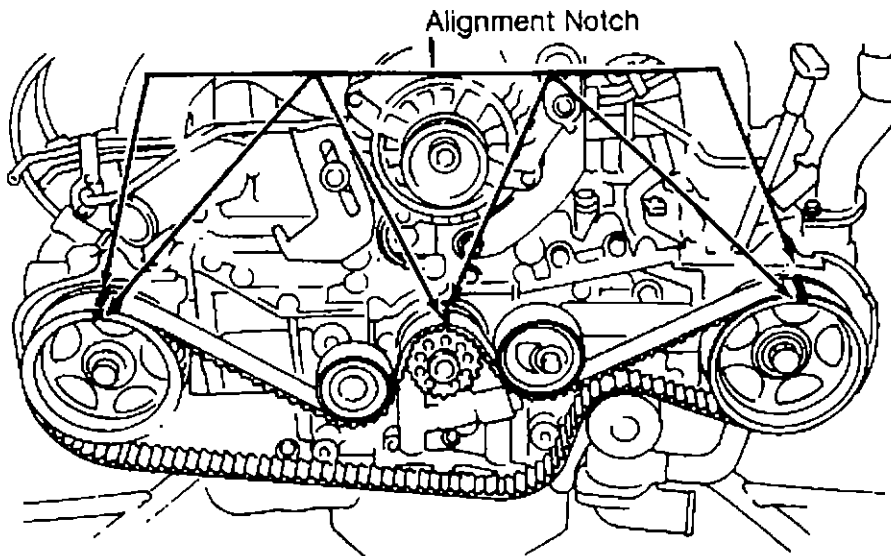

Fig. 4: Removing & Installing Timing Belt
Courtesy of Subaru of America, Inc.

Inspection

1) Inspect timing belt for wear on rounded edges of drive teeth. Inspect belt for signs of oil contamination. Replace belt if it is damaged or contaminated. Inspect belt tension adjuster oil seals for leaks. Inspect rod ends for abnormal wear and scratches. Timing belt bend radius must be greater than 2.36" (60.0 mm). See Fig. 5.

2) Slight trace of oil at rod oil seal does not indicate a problem. While holding tensioner using both hands, push rod section against floor or wall using a force of 33-110 lbs. (15-50 kg) to ensure rod section does not move.

3) If rod section moves, replace tension adjuster with a NEW one. Measure extension of rod beyond body. Rod extension should be .606-.646" (15.40-16.40 mm). Replace belt tension adjuster if extension of rod is not as specified. Inspect belt tensioner and belt adjuster rod mating surface. Check spacer and tensioner bushing.

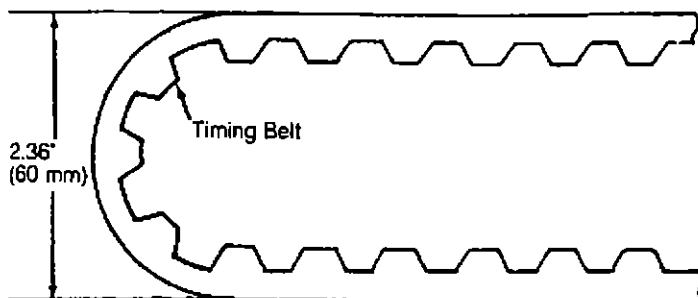

Fig. 5: Measuring Timing Belt Bend Radius
Courtesy of Subaru of America, Inc.

2.2L 4-CYL & 2.2L 4-CYL TURBO - VIN [6]

Article Text (p. 6)

1992 Subaru Legacy

For Canadian Tire 777 Niagara Street, Welland Ontario (905) 732-7501 Ext. 325

Copyright © 1997 Mitchell International

Saturday, February 20, 1999 04:12PM

CAUTION: DO NOT allow press pressure to exceed 2205 lbs. (992 kg).
DO NOT release pressure until stopper pin is completely installed.

Installation

1) Ensure timing marks are aligned. Using a press, align holes in belt tension adjuster rod and adjuster body, and push rod into body. DO NOT allow press pressure to exceed 2205 lbs. (992 kg). Install a stopper pin with a diameter of .059" (1.50 mm) into holes in adjuster body and rod. See Fig. 6.

2) Temporarily tighten mount bolts while tension adjuster is pushed completely right. Install belt tensioner. Ensure belt direction of rotation is correct.

3) Install timing belt, being careful not to move sprockets. Install belt idler No. 2 and belt idler. Loosen tension adjuster mount bolts and push tension adjuster completely left. Tighten adjuster mount bolts.

4) Ensure marks on timing belt and sprockets align. See Fig. 4. Remove stopper from tension adjuster. Remove rocker covers, and ensure valve lash adjuster does not contain air.

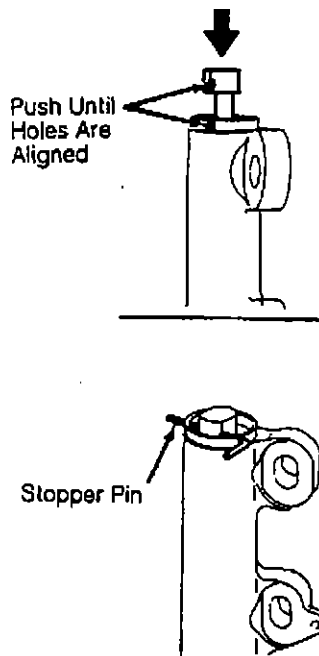

Fig. 6: Installing Tension Adjuster Rod Stopper Pin
Courtesy of Subaru of America, Inc.

ROCKER ARM ASSEMBLY

Removal & Installation

1) Disconnect PCV hose, and remove rocker cover. Remove rocker bolts No. 2-4 in order. See Fig. 7. Loosen, but DO NOT remove, bolt No. 1. Remove bolts No. 5-8. Remove rocker arm assembly.

2) Upon removal, ensure rocker arm assembly air vent is facing upward or submerge rocker arm assembly in clean engine oil.

2.2L 4-CYL & 2.2L 4-CYL TURBO - VIN [6]

Article Text (p. 7)

1992 Subaru Legacy

For Canadian Tire 777 Niagara Street, Welland Ontario (905) 732-7501 Ext. 325

Copyright © 1997 Mitchell International

Saturday, February 20, 1999 04:12PM

3) To install, reverse removal procedure. DO NOT allow rocker arm assembly to gouge dowel/alignment pins. Tighten bolts in sequence and to specification. See Fig. 7. See TORQUE SPECIFICATIONS table at end of article.

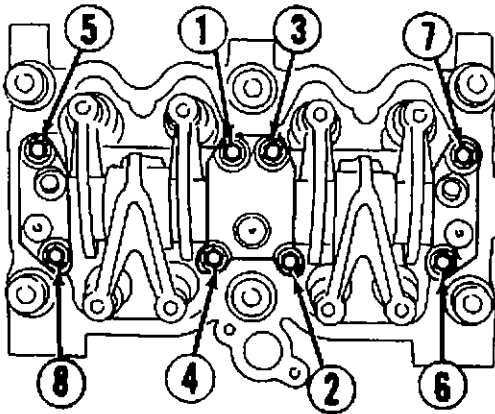

Fig. 7: Rocker Bolt Tightening Sequence
Courtesy of Subaru of America, Inc.

CAMSHAFT

Removal

Remove timing belt, camshaft sprockets and related parts. See TIMING BELT. On left camshaft, remove cam angle sensor and oil gauge guide mounting bolt. Remove left camshaft support and "O" ring. Remove left camshaft. On right camshaft, remove oil seal only if necessary. Remove camshaft.

Inspection

1) Measure bend. Bend limit is .001" (.03 mm). Check cam face condition. Remove minor burrs by grinding using oil stone. Check cam height and journal for damage wear.

2) Measure outside diameter of camshaft journal and inside diameter of cylinder head journal to determine camshaft oil clearance. If clearance is not as specified, replace camshaft or cylinder head as necessary. See CAMSHAFT table under ENGINE SPECIFICATIONS at end of article.

3) Measure camshaft end play. See CAMSHAFT table. If end play is not as specified, replace camshaft support.

Installation

1) Apply a coat of clean engine oil to both camshaft journals. Install camshaft journal. Install "O" ring to camshaft support. Install camshaft support.

2) Apply grease to NEW oil seal lips. Using Oil Seal Guide (499597000) and Oil Seal Installer (499587100), install oil seal on camshaft support. To complete installation, install rocker cover, timing belt, camshaft sprockets and related parts. Perform necessary adjustments.

2.2L 4-CYL & 2.2L 4-CYL TURBO - VIN [6]

Article Text (p. 8)

1992 Subaru Legacy

For Canadian Tire 777 Niagara Street, Welland Ontario (905) 732-7501 Ext. 325

Copyright © 1997 Mitchell International

Saturday, February 20, 1999 04:12PM

OIL PAN

Removal & Installation

Drain oil. Remove oil pan bolts. Remove oil pan and gasket. To install, reverse removal procedure using NEW gasket. Tighten bolts to specification. See TORQUE SPECIFICATIONS table at end of article.

OVERHAUL

CYLINDER HEAD

Valve Springs

Measure free length of valve springs. Check spring tension at specified height. Replace springs if they are not within specification. Check valve spring for squareness. See VALVES & VALVE SPRINGS table under ENGINE SPECIFICATIONS at end of article.

Valve Stem Oil Seals

With valves removed, remove oil seals from cylinder head. Note location of oil seals. Intake valve stem seal is Black with White spring. Exhaust valve stem seal is Brown with White spring. Coat seals with oil. Using Valve Stem Oil Seal Guide (498857100), install valve stem oil seal.

Valve Guides

1) Check clearance between valve guide and stem. Clearance is checked by measuring outside diameter of valve stem and inside diameter of valve guide using an outside and inside micrometer.

2) If clearance is not as specified, replace valve guide. See CYLINDER HEAD table under ENGINE SPECIFICATIONS at end of article. To replace valve guide, position cylinder head with combustion chamber facing upward. Insert Valve Guide Remover (499767200) into valve guide and press down to remove valve guide.

3) Invert cylinder head and place Valve Guide Adjuster (499767000) in position shown. See Fig. 8. Coat NEW valve guide with engine oil. Insert Valve Guide Remover (499767200) into NEW valve guide. Press in until valve guide upper end is flush with upper surface of valve guide adjuster.

4) Check valve protrusion. Valve guide protrusion should be .69-.71" (17.5-18.0 mm). Ream inside of valve guide using Valve Guide Reamer (499767400). Ensure all chips and metal particles are cleaned from valve guide. Recheck contact between valve and valve seat after replacing valve guide.

2.2L 4-CYL & 2.2L 4-CYL TURBO - VIN [6]

Article Text (p. 9)

1992 Subaru Legacy

For Canadian Tire 777 Niagara Street, Welland Ontario (905) 732-7501 Ext. 325

Copyright © 1997 Mitchell International

Saturday, February 20, 1999 04:12PM

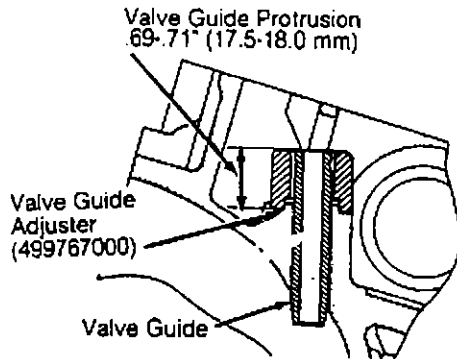

Fig. 8: Positioning Valve Guide Adjuster On Cylinder Head
Courtesy of Subaru of America, Inc.

Valve Seat

Inspect intake and exhaust valve seats. When valve guides are replaced, correct contact surfaces with valve seat cutter if surfaces are defective. See CYLINDER HEAD table under ENGINE SPECIFICATIONS at end of article.

Valves

Measure valve stem diameter and valve margin. Replace valves if they are not within specification. See VALVES & VALVE SPRINGS table under ENGINE SPECIFICATIONS at end of article. Recheck valve margin after grinding valves.

VALVE TRAIN

Rocker Arm Shaft Assembly

Check oil clearance between valve rocker arm and shaft. Clearance should be .0008-.0032" (.020-.081 mm) with a limit of .004" (.10 mm). Replace valve rocker or shaft if clearance is not as specified.

Lash Adjuster

1) Dip valve lash adjuster in engine oil. Push check ball in using .08" (2 mm) diameter round bar. With check ball pushed in, manually move plunger up and down at one-second intervals until air bubbles disappear.

2) After air bubbles disappear, remove bar and quickly push plunger in to ensure it is locked. If plunger does not lock properly, replace valve lash adjuster. Always leave valve lash adjuster in engine oil until it is ready for installation.

CYLINDER BLOCK ASSEMBLY

Cylinder Block Disassembly

1) Set up cylinder block so cylinders No. 1 and 3 are on upper side. Remove cylinder block connecting bolts. Separate left and right cylinder blocks. DO NOT allow connecting rod to fall and damage block.

2.2L 4-CYL & 2.2L 4-CYL TURBO - VIN [6]

Article Text (p. 10)

1992 Subaru Legacy

For Canadian Tire 777 Niagara Street, Welland Ontario (905) 732-7501 Ext. 325

Copyright © 1997 Mitchell International

Saturday, February 20, 1999 04:12PM

2) Remove rear oil seal. Remove crankshaft together with connecting rod. Remove crankshaft bearings from cylinder block using hammer handle. Ensure bearings are marked for proper location. Draw out each piston from cylinder block.

Crankshaft & Connecting Rod Removal

1) Separate cylinder block. See CYLINDER BLOCK DISASSEMBLY. Remove connecting rod cap. Remove connecting rod bearing. Note connecting rod cap and bearing locations.

2) Remove piston rings and oil ring. Mark rings for proper order/location. Remove circlip from piston pin. Remove piston pin. Separate piston from connecting rod.

Crankshaft & Connecting Rod Inspection

1) Inspect crankshaft for cracks. Check crankshaft runout at center journal and journal out-of-round. Repair or replace crankshaft if it is not within specification. See CRANKSHAFT, MAIN & CONNECTING ROD BEARINGS table under ENGINE SPECIFICATIONS at end of article.

2) Check connecting rod for bend and twist. Measure crankpin and piston pin bore inside diameter. Replace connecting rod if it is not within specification. See CONNECTING RODS table under ENGINE SPECIFICATIONS at end of article.

Crankshaft & Connecting Rod Installation

1) Lubricate and install bearings in connecting rod. Install connecting rod in proper cylinder location with identification mark toward front of crankshaft with matching numbers aligned.

2) Apply oil to connecting rod bolt threads before tightening nut. Check rod bearing oil clearance using Plastigage method. Replace rod bearings to obtain correct clearance. See CRANKSHAFT, MAIN & CONNECTING ROD BEARINGS table under ENGINE SPECIFICATIONS at end of article.

3) Install main bearings in cylinder block. Install crankshaft in left side of cylinder block. Using feeler gauge, measure crankshaft end play between center bearing and crankshaft.

4) Replace bearing if end play is not within specification. See CRANKSHAFT, MAIN & CONNECTING ROD BEARINGS table. Install right side of cylinder block to check oil clearance using Plastigage method.

5) Tighten bolts to specification. See TORQUE SPECIFICATIONS table at end of article. Check main bearing oil clearance. Replace main bearings to obtain correct clearance. See CRANKSHAFT, MAIN & CONNECTING ROD BEARINGS table. Reassemble cylinder block.

Piston & Rod Assembly Removal

Remove crankshaft and rod assembly. See CRANKSHAFT & CONNECTING ROD REMOVAL. Note direction of piston installation and cylinder location. Using soft hammer, drive pistons from cylinder block.

Piston & Rod Assembly Inspection

1) Inspect piston for cracks or damage in ring areas. Check ring side clearance. Measure piston pin O.D. and piston pin bore I.D.

2.2L 4-CYL & 2.2L 4-CYL TURBO - VIN [6]

Article Text (p. 11)

1992 Subaru Legacy

For Canadian Tire 777 Niagara Street, Welland Ontario (905) 732-7501 Ext. 325

Copyright © 1997 Mitchell International

Saturday, February 20, 1999 04:12PM

Replace piston if measurements are not within specification.

2) See PISTONS, PINS & RINGS and CONNECTING RODS tables under ENGINE SPECIFICATIONS at end of article. Ensure piston pin can be installed in piston at 68°F (20°C). Replace components if piston pin cannot be installed.

Piston & Rod Assembly Installation

1) Ensure piston ring end gap and side clearance are within specification. See PISTONS, PINS & RINGS table under ENGINE SPECIFICATIONS at end of article. Install rings on piston with "R" mark toward top of piston. Lubricate piston, rings and cylinder bore with engine oil.

2) Properly space ring end gaps on piston. See Fig. 9. Bend pawl of upper rail over and install it in piston hole. Install piston into cylinder bore.

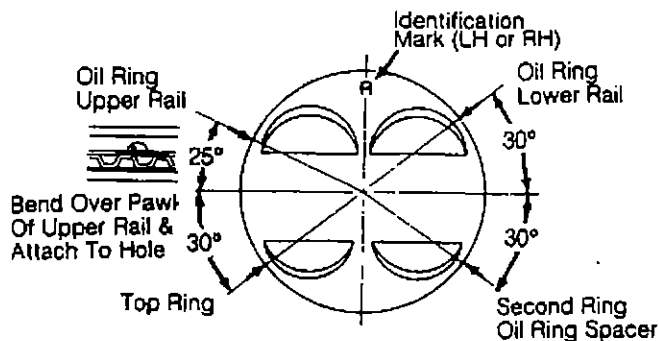

Fig. 9: Positioning Piston Rings
Courtesy of Subaru of America, Inc.

Piston & Piston Pin Inspection

1) Check piston, piston pins and piston ring grooves for damage, cracks and wear. Replace components as necessary. Measure piston-to-cylinder clearance. See PISTONS, PINS & RINGS table under ENGINE SPECIFICATIONS at end of article.

2) If clearance is not as specified, replace piston or bore cylinder and use an oversized piston. Ensure piston pin can be inserted into piston hole using thumb pressure at 68°F (20°C). Replace pin if it is defective.

Piston & Piston Pin Replacement

1) Turn cylinder block so cylinders No. 1 and 2 face up. Turn crankshaft so cylinders No. 1 and 2 connecting rods are set at bottom dead center. Apply engine oil to pistons and cylinders. Insert pistons into cylinders.

2) Coat Piston Pin Guide (498747100) with oil. Insert guide into service hole to align piston pin hole with connecting rod small end. Coat piston pin with oil, and insert piston pin into piston and connecting rod through service hole. Install circlip. Install service hole plug and gasket.

3) Invert cylinder block so cylinders No. 3 and 4 face up. Turn crankshaft so cylinders No. 3 and 4 connecting rods are set at

2.2L 4-CYL & 2.2L 4-CYL TURBO - VIN [6]

Article Text (p. 12)

1992 Subaru Legacy

For Canadian Tire 777 Niagara Street, Welland Ontario (905) 732-7501 Ext. 325

Copyright © 1997 Mitchell International

Saturday, February 20, 1999 04:12PM

bottom dead center. Apply engine oil to pistons and cylinders. To complete installation, repeat step 2).

ENGINE OILING

ENGINE LUBRICATION SYSTEM

Oil pressure is provided by a trochoid-type pump driven by timing belt. Pressure relief valve is located in oil pump body.

Crankcase Capacity

Crankcase capacity is 5.0 qts. (4.7L) with filter replacement.

Oil Pressure

With engine at normal operating temperature, pressure should be 14 psi (1.0 kg/cm²) at 600 RPM and 43 psi (3.0 kg/cm²) at 5000 RPM.

OIL PUMP

Removal

Disconnect negative battery cable. Drain engine oil. Remove timing belt covers, drive belt and related parts. See TIMING BELT under REMOVAL & INSTALLATION. Remove belt tensioner bracket. Remove water pump. Remove oil pump assembly and gasket.

Disassembly & Inspection

1) Disassemble pump. See Fig. 10. Measure tip clearance of rotors. See OIL PUMP SPECIFICATIONS table. If clearance is not as specified, replace rotors as a matched set.

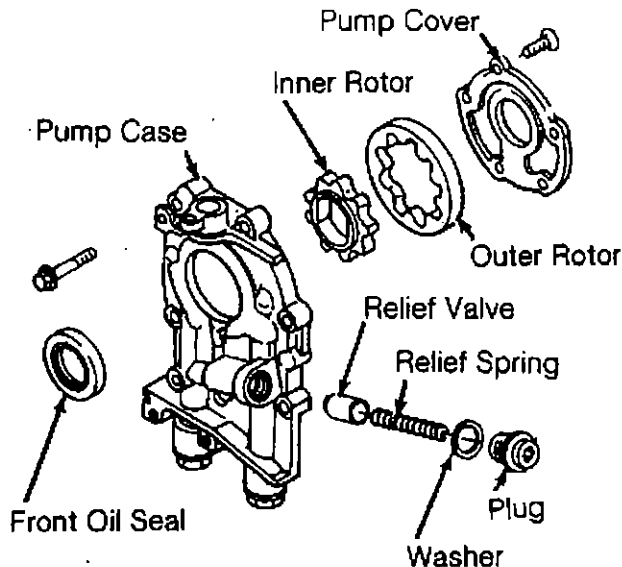

Fig. 10: Identifying Oil Pump Components
Courtesy of Subaru of America, Inc.

2.2L 4-CYL & 2.2L 4-CYL TURBO - VIN [6]

Article Text (p. 13)

1992 Subaru Legacy

For Canadian Tire 777 Niagara Street, Welland Ontario (905) 732-7501 Ext. 325

Copyright © 1997 Mitchell International

Saturday, February 20, 1999 04:12PM

OIL PUMP SPECIFICATIONS TABLE

Application	In. (mm)
Inner Rotor-To-Pump	
Case Side Clearance0008-.0028 (.020-.070)
Inner Rotor Tip-To-Outer	
Rotor Clearance (1)	.0016-.0055 (.040-.140)
Outer Rotor-To-Case Clearance (2)	.004-.007 (.10-.18)
Relief Valve Spring (3)	
Free Length	2.92 (74.2)
Installed Length	2.21 (56.1)

- (1) - Service limit is .007" (.18 mm).
(2) - Service limit is .008" (.20 mm).
(3) - Relief valve spring installed load is 18.32 lbs. (8.31 kg)

2) Measure clearance between outer rotor and oil pump cylinder block rotor housing. If case clearance is not as specified, replace rotor. See OIL PUMP SPECIFICATIONS table.

3) Measure clearance between oil pump inner rotor and pump cover. If clearance is not as specified, replace rotor or pump body. See OIL PUMP SPECIFICATIONS table:

4) Check oil relief valve and relief spring for wear and damage. Check oil pump case for worn shaft hole, clogged oil passage, worn rotor chamber and cracks. Check oil seal lips for deformation, hardening and wear. Replace components as necessary.

Reassembly & Installation

Install front oil seal using Oil Seal Installer (499587100). Install inner and outer rotors, oil relief valve, relief spring and oil pump cover. See Fig. 10. To complete installation, reverse removal procedure. Replace "O" ring.

WATER PUMP R & I

Removal

1) Disconnect negative battery cable. Drain engine coolant. Disconnect radiator outlet hose clamp. See Fig. 11. Remove radiator/fan assembly as a unit. See Fig. 12.

2.2L 4-CYL & 2.2L 4-CYL TURBO - VIN [6]

Article Text (p. 14)

1992 Subaru Legacy

For Canadian Tire 777 Niagara Street, Welland Ontario (905) 732-7501 Ext. 325

Copyright © 1997 Mitchell International

Saturday, February 20, 1999 04:12PM

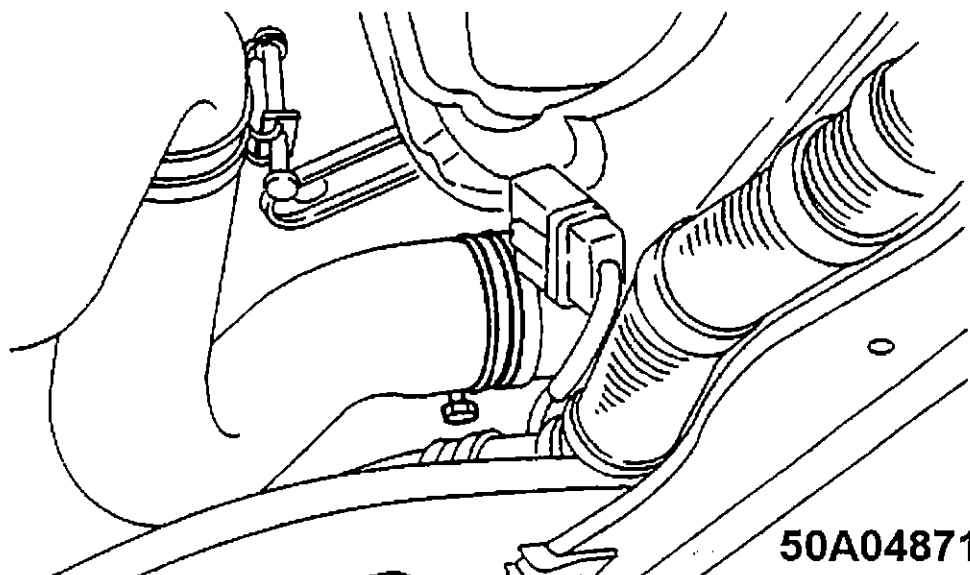

Fig. 11: Radiator Outlet Hose Identification
Courtesy of Subaru of America, Inc.

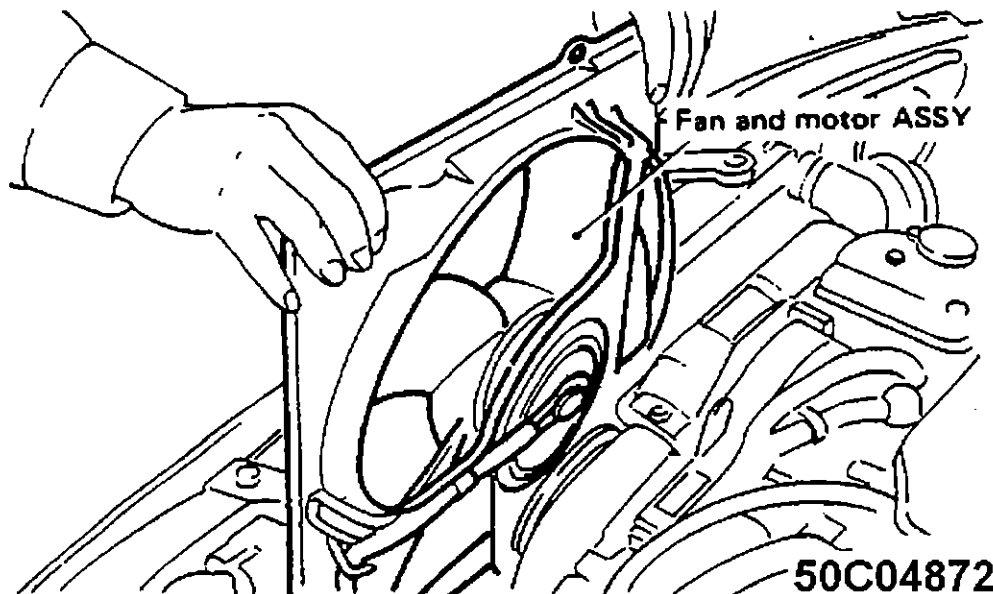

Fig. 12: Removing Radiator/Fan Assembly
Courtesy of Subaru of America, Inc.

2) Remove "V" belts and timing belt. See TIMING BELT R & I in this article. Remove belt tensioner adjuster. Remove camshaft angle sensor. Remove water pump. Remove oil pump assembly and gasket. Remove left camshaft pulley. See Fig. 13. Remove left side rear timing belt cover. See Fig. 14.

2.2L 4-CYL & 2.2L 4-CYL TURBO - VIN [6]

Article Text (p. 15)

1992 Subaru Legacy

For Canadian Tire 777 Niagara Street, Welland Ontario (905) 732-7501 Ext. 325

Copyright © 1997 Mitchell International

Saturday, February 20, 1999 04:12PM

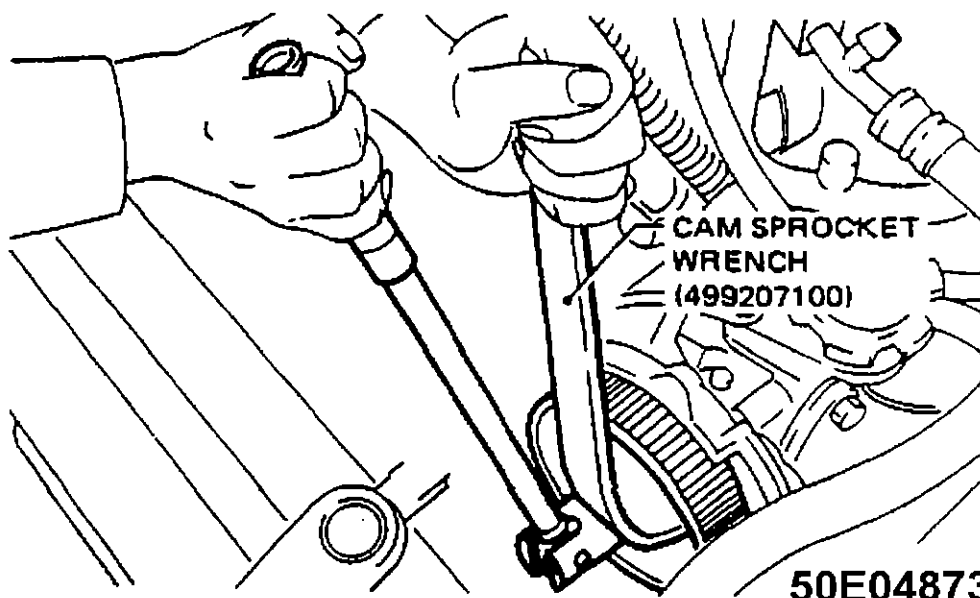

50E04873

Fig. 13: Removing Left Camshaft Pulley
Courtesy of Subaru of America, Inc.

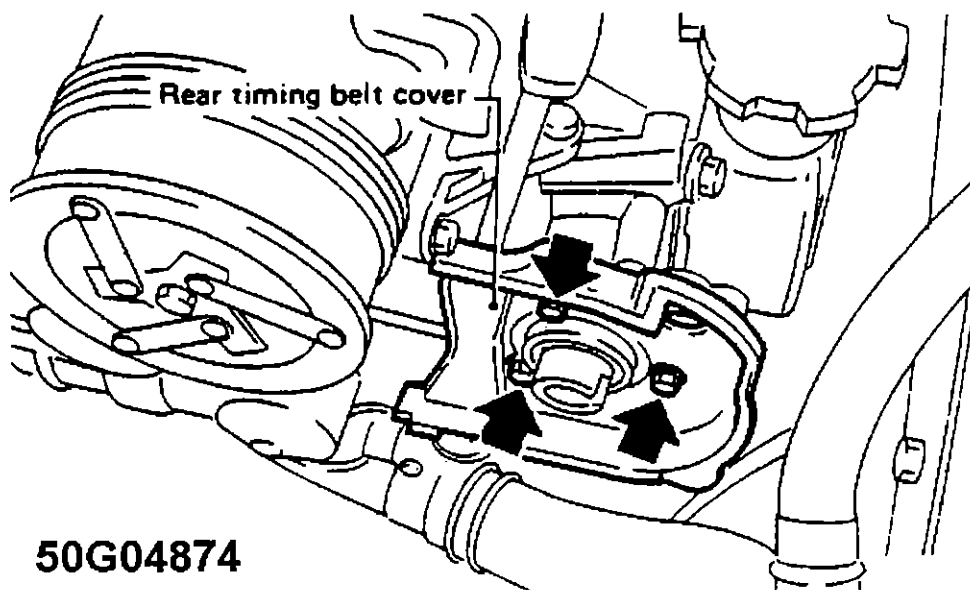

50G04874

Fig. 14: Removing Left Side Rear Timing Belt Cover
Courtesy of Subaru of America, Inc.

3) Remove belt tensioner bracket. Disconnect radiator hose and heater hose from water pump. Remove water pump attaching bolts and water pump. See Fig. 15.

2.2L 4-CYL & 2.2L 4-CYL TURBO - VIN [6]

Article Text (p. 16)

1992 Subaru Legacy

For Canadian Tire 777 Niagara Street, Welland Ontario (905) 732-7501 Ext. 325

Copyright © 1997 Mitchell International

Saturday, February 20, 1999 04:12PM

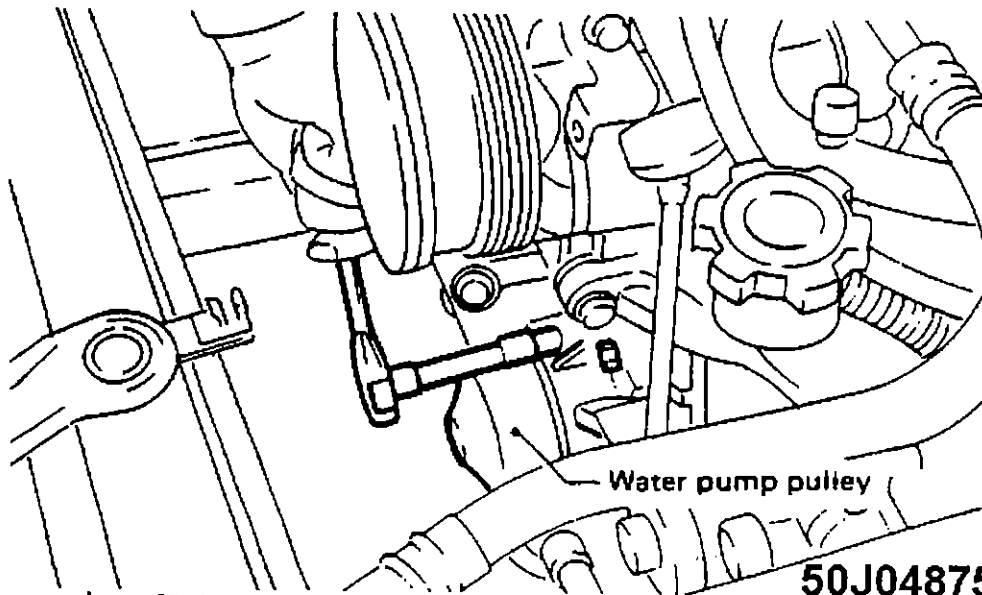

Fig. 15: Removing Water Pump
Courtesy of Subaru of America, Inc.

Inspection

1) Check water pump for smooth operation. Check water pump pulley for any problems. Using dial indicator, check the runout of the impeller while rotating the pulley. See WATER PUMP SPECIFICATIONS table below. If runout is not as specified, replace water pump.

2) Measure clearance between impeller and water pump housing. If clearance is not as specified, replace rotor. See WATER PUMP SPECIFICATIONS table below.

WATER PUMP SPECIFICATIONS

Application	In. (mm)
Maximum Runout020 (.5)
Impeller-to-Housing Clearance	
Standard020-.028 (.5-.7)
Limit039 (1.0)

2.2L 4-CYL & 2.2L 4-CYL TURBO - VIN [6]

Article Text (p. 17)

1992 Subaru Legacy

For Canadian Tire 777 Niagara Street, Welland Ontario (905) 732-7501 Ext. 325

Copyright © 1997 Mitchell International

Saturday, February 20, 1999 04:12PM

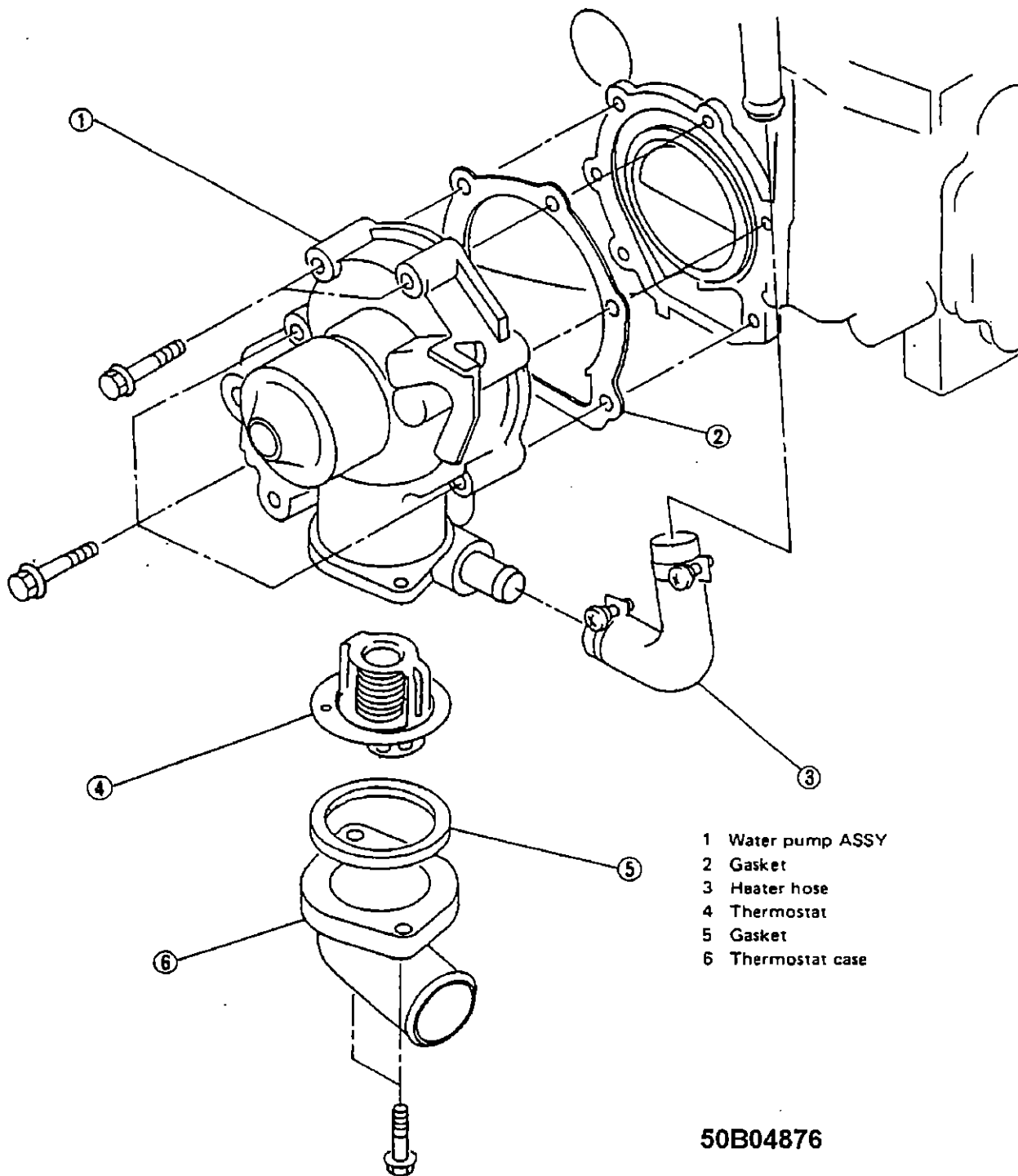

Fig. 16: Water Pump Components
Courtesy of Subaru of America, Inc.

Installation

Install water pump using new gaskets and seals. To complete installation, reverse removal procedure. Check for leaks or abnormal noise. If leaks or excessive noise exists, replace water pump.

2.2L 4-CYL & 2.2L 4-CYL TURBO - VIN [6]

Article Text (p. 18)

1992 Subaru Legacy

For Canadian Tire 777 Niagara Street, Welland Ontario (905) 732-7501 Ext. 325

Copyright © 1997 Mitchell International

Saturday, February 20, 1999 04:12PM

TORQUE SPECIFICATIONS

TORQUE SPECIFICATIONS TABLE

Application	Ft. Lbs. (N.m)
Camshaft Sprocket Bolt	55-61 (75-83)
Camshaft Support Bolt	12 (16)
Connecting Rod Cap Nut	32-34 (43-46)
Crankshaft Pulley Bolt	69-76 (93-103)
Cylinder Block Bolt (Left-To-Right)	17-20 (23-27)
Cylinder Block Service Hole Plug	46-56 (62-76)
Cylinder Head Bolt (1)	33-37 (45-50)
Drive Plate Reinforcement Bolt	51-55 (69-75)
Flywheel Bolt	51-55 (69-75)
Timing Belt Idler Bolt	26-32 (35-43)
Timing Belt Tension Adjuster Bolt	17-20 (23-27)
Timing Belt Tensioner Bracket Bolt	17-20 (23-27)

INCH Lbs. (N.m)

Oil Pan Bolt	44 (5.0)
Oil Pump Bolt	58 (6.4)
Rocker Cover Bolt	44 (5.0)
Rocker Shaft Support Bolt	
Long	108 (12.2)
Short	44 (5.0)
Thermostat-to-Water Pump Bolt	52-61 (6-7)
Timing Belt Cover Bolt	44 (5.0)
Water Pump Bolt	89-124 (10.0-14.0)

- (1) - Using NEW head gasket, tighten head bolts to 21 ft. lbs. (29 N.m) and then to 51 ft. lbs. (69 N.m). Back out head bolts 180 degrees and then another 180 degrees. On non-turbo engines, tighten bolts No. 1 and 2 to 25 ft. lbs. (34 N.m). Tighten bolts No. 3, 4, 5 and 6 to 11 ft. lbs. (15 N.m). On turbo engines, tighten bolts No. 1 and 2 to 27 ft. lbs. (36 N.m). Tighten bolts No. 3, 4, 5, and 6 to 14 ft. lbs. (20 N.m). On all engines, tighten bolts an additional 180 degrees in 2 equal steps. See Fig. 1.

ENGINE SPECIFICATIONS

GENERAL ENGINE SPECIFICATIONS

GENERAL SPECIFICATIONS TABLE

Application	Specification
-------------	---------------

2.2L 4-CYL & 2.2L 4-CYL TURBO - VIN [6]

Article Text (p. 19)

1992 Subaru Legacy

For Canadian Tire 777 Niagara Street, Welland Ontario (905) 732-7501 Ext. 325

Copyright © 1997 Mitchell International

Saturday, February 20, 1999 04:13PM

Displacement	135 Cu. In. (2.2L)
Bore	3.82" (97.0 mm)
Stroke	2.95" (75.0 mm)
Compression Ratio	
Non-Turbo	9.5:1
Turbo	8.0:1
Fuel System	PFI
Horsepower @ RPM	
Non-Turbo	130 @ 5600
Turbo	160 @ 5600
Torque Ft. Lbs. @ RPM	
Non-Turbo	137 @ 4400
Turbo	181 @ 2800
Turbo Boost Pressure (Maximum)	8.7 psi

CRANKSHAFT, MAIN & CONNECTING ROD BEARINGS SPECIFICATIONS

CRANKSHAFT, MAIN & CONNECTING ROD BEARINGS SPECIFICATIONS TABLE

Application	In. (mm)
Crankshaft	
End Play	
Standard	.0012-.0045 (.030-.115)
Service Limit	.0098 (.250)
Runout	.0014 (.035)
Main Bearings	
Journal Diameter	2.3616-2.3622 (59.984-60.000)
Journal Out-Of-Round	.0012 (.030)
Journal Grinding Limit	.0098 (.250)
Journal Taper	
Standard	.0002 (.005)
Service Limit	.0004 (.010)
Oil Clearance	
Except Journals No. 1 & 5	
Standard	.0004-.0012 (.010-.030)
Service Limit	.0014 (.035)
Journals No. 1 & 5	
Standard	.0004-.0012 (.010-.030)
Service Limit	.0016 (.040)
Connecting Rod Bearings	
Journal Diameter	2.0466-2.0472 (51.984-52.000)
Journal Out-Of-Round	.0012 (.030)
Journal Grinding Limit	.0098 (.250)
Journal Taper Limit	.0004 (.010)
Oil Clearance	

2.2L 4-CYL & 2.2L 4-CYL TURBO - VIN [6]

Article Text (p. 20)

1992 Subaru Legacy

For Canadian Tire 777 Niagara Street, Welland Ontario (905) 732-7501 Ext. 325

Copyright © 1997 Mitchell International

Saturday, February 20, 1999 04:13PM

Standard	.00060-.00170
	(.0158-.0438)
Service Limit	.002 (.05)

CONNECTING RODS SPECIFICATIONS

CONNECTING RODS SPECIFICATIONS TABLE

Application	In. (mm)
Bore Diameter	
Crankpin Bore	2.1050-2.1060 (53.476-53.501)
Piston Pin Bore	.9062-.9064 (23.017-23.023)
Side Play	
Standard	.0028-.0130 (.070-.330)
Service Limit	.016 (.40)

PISTONS, PINS & RINGS SPECIFICATIONS

PISTONS, PINS & RINGS SPECIFICATIONS TABLE

Application	In. (mm)
Pistons	
Clearance	.0004-.0012 (.010-.030)
Diameter (1)	
Standard	
A	3.8144-3.8148 (96.885-96.895)
B	3.8140-3.8144 (96.875-96.885)
C	3.8136-3.8140 (96.865-96.875)
Pins	
Diameter	.9053-.9055 (22.994-23.000)
Piston Fit	(2)
Piston-To-Pin Clearance	.0002-.0003 (.004-.008)
Rings	
No. 1	
Non-Turbo	
End Gap	
Standard	.0079-.0138 (.200-.350)
Service Limit	.039 (1.00)
Side Clearance	
Standard	.0016-.0031 (.041-.080)
Service Limit	.0059 (.150)
Turbo	
End Gap	
Standard	.0079-.0098 (.200-.250)
Service Limit	.035 (.90)
Side Clearance	
Standard	.0016-.0031 (.041-.080)
Service Limit	.0059 (.150)

2.2L 4-CYL & 2.2L 4-CYL TURBO - VIN [6]

Article Text (p. 21)

1992 Subaru Legacy

For Canadian Tire 777 Niagara Street, Welland Ontario (905) 732-7501 Ext. 325

Copyright © 1997 Mitchell International

Saturday, February 20, 1999 04:13PM

No. 2

End Gap

Standard0146-.0205 (.370-.520)

Service Limit039 (1.00)

Side Clearance

Standard0012-.0028 (.030-.070)

Service Limit0059 (.150)

No. 3 (Oil)

End Gap

Standard008-.028 (.20-.70)

Service Limit059 (1.50)

Side Clearance

..... 0 (0)

(1) - Measure at .59" (15.0 mm) from bottom of skirt.

(2) - Thumb press fit at 68°F (20°C).

CYLINDER BLOCK SPECIFICATIONS

CYLINDER BLOCK SPECIFICATIONS TABLE

Application	In. (mm)
Cylinder Bore	
Standard Diameter	
A	3.8151-3.8155 (96.905-96.915)
B	3.8148-3.8151 (96.895-96.905)
C	3.8144-3.8148 (96.885-96.895)
Maximum Taper002 (.05)
Maximum Deck Warpage002 (.05)
Maximum Boring Limit020 (.50)
Maximum Surface Grinding Limit004 (.10)
Out-Of-Round	
Standard0004 (.010)
Service Limit0020 (.050)

VALVES & VALVE SPR SPECIFICATIONS

VALVES & VALVE SPR SPECIFICATIONS TABLE

Application	Specification
Intake Valves	
Face Angle	45°
Head Diameter	(1)
Minimum Margin	
Standard039" (1.00 mm)
Service Limit031" (0.80 mm)
Stem Diameter	
Standard2343-.2348" (5.950-5.965 mm)
Exhaust Valves	

2.2L 4-CYL & 2.2L 4-CYL TURBO - VIN [6]

Article Text (p. 22)

1992 Subaru Legacy

For Canadian Tire 777 Niagara Street, Welland Ontario (905) 732-7501 Ext. 325

Copyright © 1997 Mitchell International

Saturday, February 20, 1999 04:13PM

Face Angle	45°
Head Diameter	(1)
Minimum Margin	
Standard047" (1.20 mm)
Service Limit031" (0.80 mm)
Stem Diameter	
Standard2341-.2346" (5.945-5.960 mm)
Valve Springs	
Free Length	1.8173" (46.160 mm)
Out-Of-Square079" (2.00 mm)
	Lbs. @ In. (kg @ mm)
Pressure	
Valve Closed	42.8-49.4 @ 1.457 (19.4-22.4 @ 37.00)
Valve Open	90.2-103.9 @ 1.150 (40.9-47.1 @ 29.20)

(1) - Information is not available from manufacturer.

CYLINDER HEAD SPECIFICATIONS

CYLINDER HEAD SPECIFICATIONS TABLE

Application	Specification
Cylinder Head	
Height	3.870" (98.30 mm)
Maximum Warpage	(1) .002" (.05 mm)
Valve Seats	
Intake Valve	
Seat Angle	45°
Seat Width	
Standard028 (.70)
Service Limit055" (1.40 mm)
Exhaust Valve	
Seat Angle	45°
Seat Width	
Standard039" (1.00 mm)
Service Limit071" (1.80 mm)
Valve Guides	
Intake Valve	
Valve Guide I.D.2362-.2367" (6.000-6.012 mm)
Valve Guide Installed Height689-.709"
	(17.50-18.00 mm)
Valve Stem-To-Guide	
Oil Clearance	
Standard0014-.0024" (.035-.062 mm)
Service Limit006" (.15 mm)
Exhaust Valve	
Valve Guide I.D.2362-.2367" (6.000-6.012 mm)
Valve Guide Installed Height ..	.689-.709" (17.5-18.0 mm)
Valve Stem-To-Guide	

2.2L 4-CYL & 2.2L 4-CYL TURBO - VIN [6]

Article Text (p. 23)

1992 Subaru Legacy

For Canadian Tire 777 Niagara Street, Welland Ontario (905) 732-7501 Ext. 325

Copyright © 1997 Mitchell International

Saturday, February 20, 1999 04:13PM

Oil Clearance

Standard0016-.0026" (.040-.067 mm)
Service Limit006" (.15 mm)

(1) - Maximum resurface limit is .004" (0.10 mm).

CAMSHAFT SPECIFICATIONS

CAMSHAFT SPECIFICATIONS TABLE

Application	In. (mm)
End Play	
Standard	.0012-.0102 (.030-.260)
Service Limit	.00138 (.0350)
Journal Runout	.0010 (.025)
Oil Clearance	
Standard	.0022-.0035 (.055-.090)
Service Limit	.0039 (.100)
Lobe Height	
Non-Turbo	
Standard	1.2702-1.2781 (32.264-32.464)
Service Limit	1.2642 (32.110)
Turbo	
Standard	1.2711-1.2750 (32.286-32.386)
Service Limit	1.2641 (32.04)

END OF ARTICLE

INTERFERENCE VERIFICATION CHECK FOR OHC ENGINE

Article Text

1992 Subaru Legacy

For Canadian Tire 777 Niagara Street, Welland Ontario (905) 732-7501 Ext. 325

Copyright © 1997 Mitchell International

Saturday, February 20, 1999 04:42PM

ARTICLE BEGINNING

Maintenance & Service Information
1983-93 Subaru

TIMING BELT INTERFERENCE VERIFICATION INFORMATION

TIMING BELT INTERFERENCE CAUTION

NOTE: CAMSHAFT DRIVE BELTS OR TIMING BELTS - The condition of camshaft drive belts should always be checked on vehicles which have more than 50,000 miles. Although some manufacturers do not recommend replacement at a specified mileage, others require it at 60,000-100,000 miles. A camshaft drive belt failure may cause extensive damage to internal engine components on most engines, although some designs do not allow piston-to-valve contact. These designs are often called "Free Wheeling". Many manufacturers changed their maintenance and warranty schedules in the mid-1980's to reflect timing belt inspection and/or replacement at 50,000-60,000 miles. Most service interval schedules shown in this section reflect these changes. Belts or components should be inspected and replaced if any of the following conditions exist:

- * Crack Or Tears In Belt Surface
- * Missing, Damaged, Cracked Or Rounded Teeth
- * Oil Contamination
- * Damaged Or Faulty Tensioners
- * Incorrect Tension Adjustment

TIMING BELT INTERFERENCE CHECK MENU

TIMING BELT INTERFERENCE VERIFICATION

(DAMAGE TO PISTON AND/OR VALVES CAUSED BY TIMING BELT FAILURE)

Application (Model & Engine)	Recommended Replacement Interval Miles (Kilometers)	(1) Check For Possible Damage: Yes/No
1.2L 3-Cyl.	None	N/A
1.6L 4-Cyl.	None	N/A
1.8L 4-Cyl.	None	N/A
2.2L 4-Cyl.	None	N/A
2.7L 6-Cyl.	None	N/A

- (1) - Yes = Check for possible damage to piston(s) or valve(s) if there has been a timing belt failure.
No = Manufacturer does not recommend piston or valve inspection in the event of a timing belt failure.
N/A = Timing belt failure information not available or not specified by the manufacturer.

C - SPECIFICATIONS

Article Text

1992 Subaru Legacy

For Canadian Tire 777 Niagara Street, Welland Ontario (905) 732-7501 Ext. 325

Copyright © 1997 Mitchell International

Monday, February 22, 1999 01:44PM

ARTICLE BEGINNING

1992 ENGINE PERFORMANCE
Subaru Service & Adjustment Specifications

Justy, Legacy, Loyale, SVX

INTRODUCTION

Use this article to quickly find specifications related to servicing and on-vehicle adjustments. This is a quick-reference article to use when you are familiar with an adjustment procedure and only need a specification.

CAPACITIES

BATTERY SPECIFICATIONS TABLE

Application	Amp Hr. Rating
Justy	52
Legacy	99 Or 111
Loyale	78 Or 111
SVX	133

FLUID CAPACITIES TABLE

Application	Quantity
Justy	
Cooling System (Including Heater)	
Carbureted	4.9 Qts. (4.6L)
PFI	5.2 Qts. (4.9L)
Crankcase (Includes Filter)	3.0 Qts. (2.8L)
ECVT Transaxle (Dexron-II)	
FWD	3.5 Qts. (3.3L)
4WD	4.4 Qts. (4.2L)
Manual Transaxle (SAE 85W-90)	
FWD	2.5 Qts. (2.4L)
4WD	3.6 Qts. (3.4L)
Power Steering	1.5 Pts. (0.7L)
Rear Differential (4WD)	1.7 Pts. (0.8L)
Legacy	
Automatic Transaxle (Dexron-II)	
Non-Turbo	8.8 Qts. (8.3L)
Turbo	9.4 Qts. (8.9L)
Automatic Transaxle Differential	1.5 Qts. (1.4L)
Cooling System (Including Heater)	
Non-Turbo	6.3 Qts. (6.0L)

C - SPECIFICATIONS

Article Text (p. 2)

1992 Subaru Legacy

For Canadian Tire 777 Niagara Street, Welland Ontario (905) 732-7501 Ext. 325

Copyright © 1997 Mitchell International

Monday, February 22, 1999 01:44PM

Turbo	7.2 Qts.	(7.0L)
Crankcase (Includes Filter)		
Lower Level	3.7 Qts.	(3.5L)
Upper Level	4.8 Qts.	(4.5L)
Manual Transaxle (SAE 85W-90)		
FWD	3.5 Qts.	(3.3L)
4WD	3.7 Qts.	(3.5L)
Power Steering	1.5 Pts.	(0.7L)
Rear Differential (4WD)	1.7 Pts.	(0.8L)

Loyale

Automatic Transaxle (Dexron-II)		
FWD	6.6 Qts.	(6.2L)
4WD	7.0 Qts.	(6.6L)
Automatic Transaxle Differential	2.5 Pts.	(1.2L)
Cooling System (Including Heater)	5.8 Qts.	(5.5L)
Crankcase (Includes Filter)	4.2 Qts.	(4.0L)
Manual Transaxle (SAE 85W-90)		
FWD	2.7 Qts.	(2.6L)
4WD	3.5 Qts.	(3.3L)
Power Steering	1.5 Pts.	(0.7L)
Rear Differential (4WD)	1.7 Pts.	(0.8L)

SVX

Automatic Transmission	10.0 Qts.	(9.5L)
Automatic Transmission Differential	1.2 Pts.	(0.6L)
Cooling System (Including Heater)	7.2 Qts.	(7.0L)
Crankcase (Including Filter)	5.3 Qts.	(5.0L)
Power Steering	2.2 Pts.	(1.0L)
Rear Differential (4WD)	1.7 Pts.	(0.8L)

QUICK-SERVICE

SERVICE INTERVALS & SPECIFICATIONS

REPLACEMENT INTERVALS TABLE

Component	Interval (Miles)
Air Filter	30,000
Camshaft Timing Belt	60,000
Coolant (Radiator)	30,000
Drive Belt(s)	60,000
ECVT Fluid	30,000
Fuel Filter	30,000
Oil & Filter	3000
Spark Plugs	30,000

BELT ADJUSTMENT TABLE

C - SPECIFICATIONS

Article Text (p. 3)

1992 Subaru Legacy

For Canadian Tire 777 Niagara Street, Welland Ontario (905) 732-7501 Ext. 325

Copyright © 1997 Mitchell International

Monday, February 22, 1999 01:44PM

Application	Deflection - In. (mm)
Justy	
Alternator	
With A/C45-.49 (11.5-12.5)
Without A/C35-.39 (9.0-10.0)
Legacy	
A/C35-.39 (9.0-10.0)
Alternator & P/S35-.43 (9.0-11.0)
Loyale	
Alternator	
With A/C43-.47 (11.0-12.0)
With A/C & P/S30-.34 (7.5-8.5)
With P/S39-.43 (9.0-11.0)
Without A/C & P/S51-.59 (13.0-15.0)
SVX	
A/C28-.32 (7.0-8.0)
Alternator & P/S20-.42 (5.0-6.0)

MECHANICAL CHECKS

ENGINE COMPRESSION

COMPRESSION SPECIFICATIONS TABLE

Application	Specification
Justy	
Compression Pressure	135-156 psi (9.5-11.0 kg/cm ²)
Compression Ratio	9.1:1
Maximum Variation Between Cylinders	28 psi (2.0 kg/cm ²)
Legacy	
Compression Pressure	
Non-Turbo	156-185 psi (11.0-13.0 kg/cm ²)
Turbo	142-171 psi (10.0-12.0 kg/cm ²)
Compression Ratio	
Non-Turbo	9.5:1
Turbo	8.0:1
Maximum Variation Between Cylinders	28 psi (2.0 kg/cm ²)
Loyale	
Compression Pressure	168 psi (11.8 kg/cm ²)
Compression Ratio	9.5:1
Maximum Variation Between Cylinders	28 psi (2.0 kg/cm ²)
SVX	
Compression Pressure	171-206 psi (12.0-14.5 kg/cm ²)

C - SPECIFICATIONS

Article Text (p. 4)

1992 Subaru Legacy

For Canadian Tire 777 Niagara Street, Welland Ontario (905) 732-7501 Ext. 325

Copyright © 1997 Mitchell International

Monday, February 22, 1999 01:44PM

Compression Ratio 10.0:1
Maximum Variation Between Cylinders 28 psi (2.0 kg/cm²)

VALVE CLEARANCE

NOTE: Legacy, Loyale and SVX use hydraulic lash adjusters; adjustments are not required.

VALVE CLEARANCE SPECIFICATIONS TABLE

Application	(1) In. (mm)
Justy	
Intake006 (.15)
Exhaust010 (.25)

(1) - Adjust valves with engine cold.

IGNITION SYSTEM

IGNITION COIL

IGNITION COIL RESISTANCE TABLE

Application	Primary	Secondary
Justy	0.81-0.99	8500-11,000
Legacy		
Hitachi	0.70	13,500
Diamond	0.70	21,000
Loyale	0.84-1.02	8000-12,000
SVX	(2)	(2)

(1) - OHMS @ 68°F (20°C)

(2) - Information is not available from manufacturer.

DISTRIBUTOR SENSORS

NOTE: Information on distributor sensors is not available from manufacturer. See IGNITION CHECKS in F - BASIC TESTING article in the ENGINE PERFORMANCE Section for test procedures.

HIGH TENSION WIRE RESISTANCE

NOTE: Legacy and SVX use Direct Ignition System (DIS).

C - SPECIFICATIONS

Article Text (p. 6)

1992 Subaru Legacy

For Canadian Tire 777 Niagara Street, Welland Ontario (905) 732-7501 Ext. 325

Copyright © 1997 Mitchell International

Monday, February 22, 1999 01:44PM

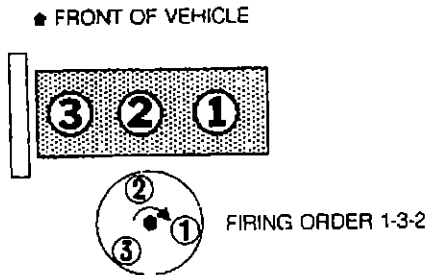
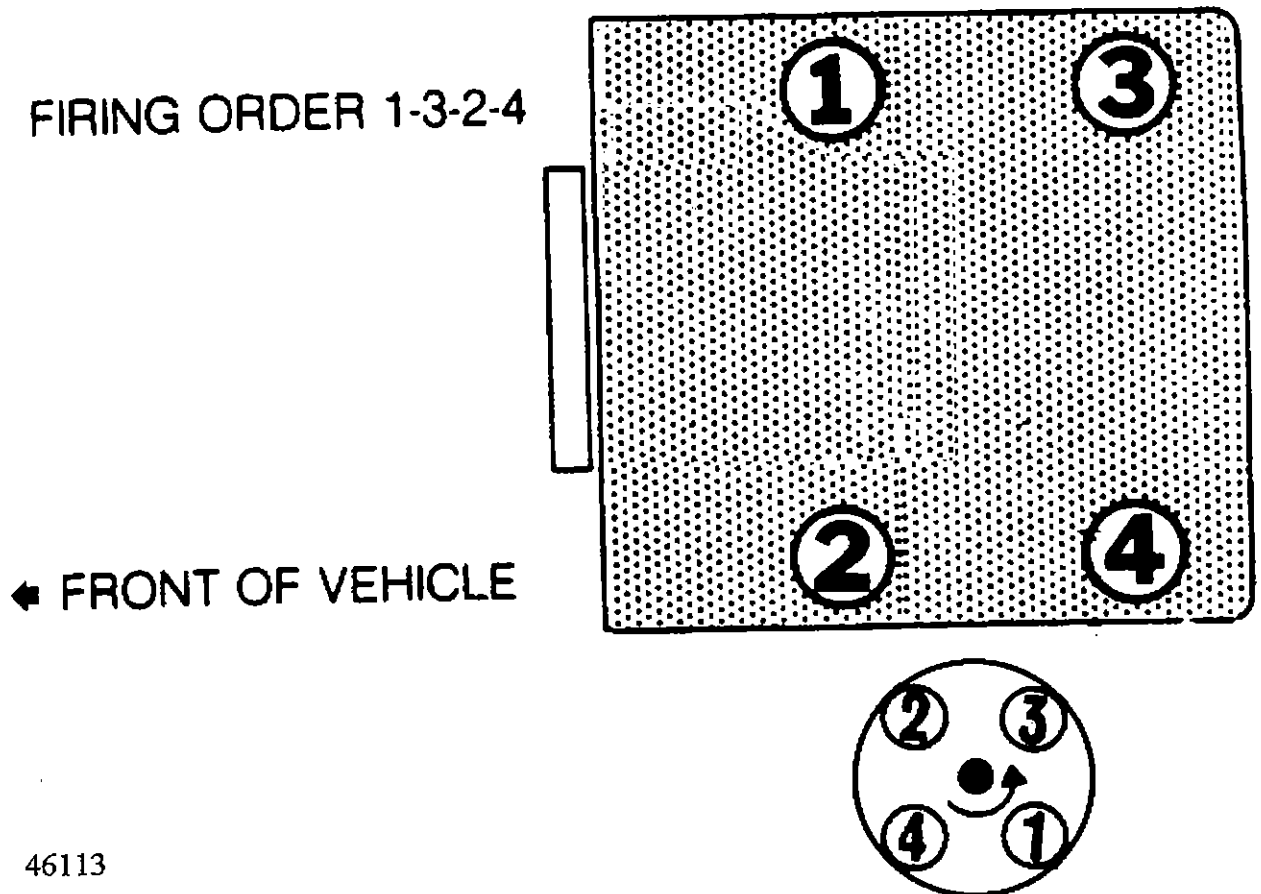

Fig. 1: 3-Cylinder Firing Order & Distributor Rotation



46113

Fig. 2: 4-Cylinder Firing Order & Distributor Rotation

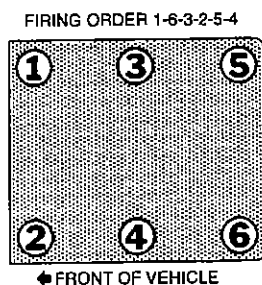

Fig. 3: 6-Cylinder Firing Order

C - SPECIFICATIONS

Article Text (p. 7)

1992 Subaru Legacy

For Canadian Tire 777 Niagara Street, Welland Ontario (905) 732-7501 Ext. 325

Copyright © 1997 Mitchell International

Monday, February 22, 1999 01:44PM

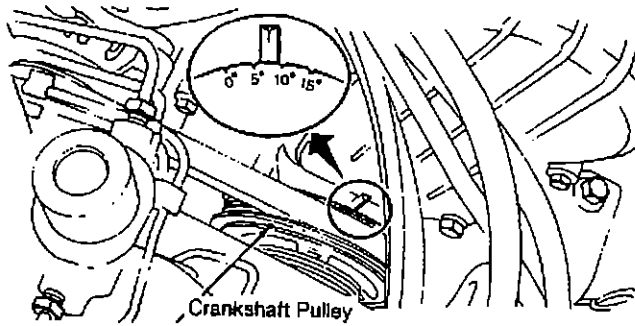

Fig. 4: Locating 3-Cylinder Ignition Timing Mark
Courtesy of Subaru of America, Inc.

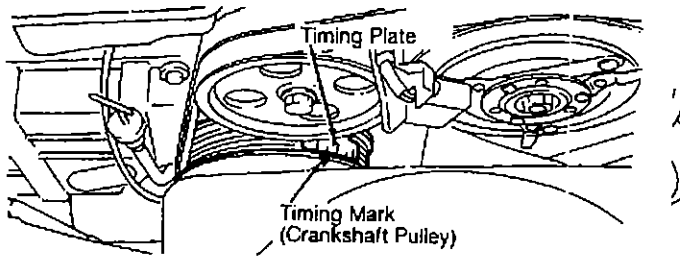

Fig. 5: Locating 4-Cylinder Ignition Timing Mark
Courtesy of Subaru of America, Inc.

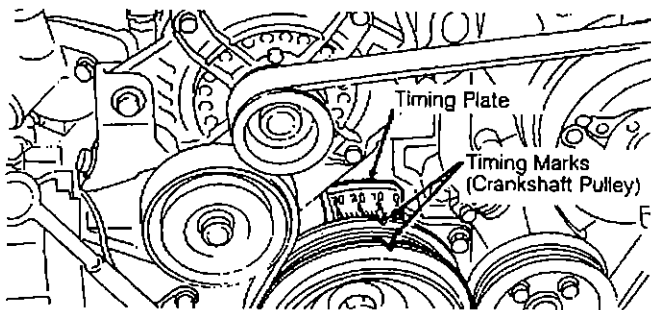

Fig. 6: Locating 6-Cylinder Ignition Timing Marks
Courtesy of Subaru of America, Inc.

IGNITION TIMING

IGNITION TIMING TABLE (1)

Application	Auto. Trans.	Man. Trans.
Justy	(2) 5 @ 800	(2) 5 @ 850
Legacy		
Non-Turbo	12-28 @ 700	18-22 @ 700
Turbo	7-23 @ 700	7-23 @ 700
Loyale	20 @ 700	20 @ 700
SVX	12-28 @ 610	

C - SPECIFICATIONS

Article Text (p. 8)

1992 Subaru Legacy

For Canadian Tire 777 Niagara Street, Welland Ontario (905) 732-7501 Ext. 325

Copyright © 1997 Mitchell International

Monday, February 22, 1999 01:44PM

- (1) - Degrees BTDC @ RPM
- (2) - With test mode connector connected.

DISTRIBUTOR SPECIFICATIONS

NOTE: All models use electronic ignition with spark timing controlled by emission system control unit.

PICK-UP COIL AIR GAP TABLE

Application	In. (mm)
Justy	.008-.016 (.20-.40)

FUEL SYSTEM

FUEL PUMP

NOTE: Fuel pump performance measures fuel pressure and volume availability, not regulated fuel pressure.

FUEL PUMP PERFORMANCE TABLE

Application	Pressure psi (kg/cm ²)	Min. Vol. In 30 Sec. Pts. (L)
Justy		
Carbureted	1.3-2.0 (.09-.14)	.35 (.17)
PFI	(1)	(1)
Legacy	36 (2.5)	1.4 (0.7)
Loyale	36-50 (2.5-3.5)	1.4 (0.7)
SVX	26-30 (1.8-2.1)	(1)

(1) - Information is not available from manufacturer.

REGULATED FUEL PRESSURE TABLE

Application	At Idle psi (kg/cm ²)
Except Justy	36 (2.6)
Justy	31-34 (2.2-2.4)

INJECTOR RESISTANCE

INJECTOR RESISTANCE SPECIFICATIONS TABLE

Application	Ohms
-------------	------

C - SPECIFICATIONS

Article Text (p. 9)

1992 Subaru Legacy

For Canadian Tire 777 Niagara Street, Welland Ontario (905) 732-7501 Ext. 325

Copyright © 1997 Mitchell International

Monday, February 22, 1999 01:44PM

Justy	10.0-18.0
Legacy & SVX	11.0-12.0
Loyale	0.5-2.0

IDLE SPEED & MIXTURE

IDLE SPEED SPECIFICATIONS TABLE

Application	RPM
Justy (1)	
Carbureted	750-850
PFI	650-750
Legacy	
With Accessories Off	600-800
With Accessories On	800-900
Loyale	500-600
SVX	
With Accessories Off	510-710
With Accessories On	750-850

(1) - With test mode and read memory connectors connected.

FAST IDLE SPEED

NOTE: Fast idle speed is not available from manufacturer. See D - ADJUSTMENTS article in the ENGINE PERFORMANCE Section for adjustment procedure.

THROTTLE POSITION SENSOR

NOTE: See D - ADJUSTMENTS article in the ENGINE PERFORMANCE Section for Throttle Position Sensor (TPS) adjustment procedure.

END OF ARTICLE

E - THEORY/OPERATION

Article Text

1992 Subaru Legacy

For Canadian Tire 777 Niagara Street, Welland Ontario (905) 732-7501 Ext. 325

Copyright © 1997 Mitchell International

Monday, February 22, 1999 01:47PM

ARTICLE BEGINNING

1992 ENGINE PERFORMANCE
Subaru Theory & Operation

Justy, Legacy, Loyale, SVX

INTRODUCTION

This article covers basic description and operation of engine performance-related systems and components. Read this article before diagnosing vehicles or systems with which you are not completely familiar.

AIR INDUCTION SYSTEM

TURBOCHARGERS

Legacy uses a water-cooled turbocharger mounted on exhaust crossover pipe. A wastegate assembly is attached to rear of turbine housing. Turbocharger consists of a turbine/compressor assembly, oil supply system, wastegate valve, and wastegate control solenoid valve. Other components include impellers, impeller shaft, bearings and impeller housings.

If intake boost pressure exceeds safe limits, engine damage may result. To prevent excessive intake boost pressure, system uses a pressure-actuated wastegate valve as a limiting device. Wastegate valve opens when intake pressure exceeds a predetermined limit, allowing exhaust gases to by-pass compressor.

Turbocharger operation requires a large quantity of clean oil to prevent bearing failure. Engine oil pressure provides constant lubrication to system.

Wastegate Control Solenoid Valve

Located in pressure line between intake manifold and wastegate valve, this duty solenoid compensates for reduced intake air volume due to high altitude. When Electronic Control Unit (ECU) energizes solenoid, valve closes. This restricts pressure line, eliminating wastegate valve by-pass function. Boost pressure is then unregulated (full volume). This maintains maximum allowable boost under high altitude conditions.

COMPUTERIZED ENGINE CONTROLS

Carbureted

Electronic Fuel Control (EFC) system is a computer-ized fuel, ignition and emission control system designed to maintain fuel economy and reduce vehicle emissions. An Electronic Control Unit (ECU) monitors data from various sensors and controls such functions as carburetor air/fuel mixture ratio, ignition timing and emission

E - THEORY/OPERATION

Article Text (p. 2)

1992 Subaru Legacy

For Canadian Tire 777 Niagara Street, Welland Ontario (905) 732-7501 Ext. 325

Copyright © 1997 Mitchell International

Monday, February 22, 1999 01:47PM

control devices.

Port Fuel Injection (PFI)

PFI system is a computerized fuel, ignition and emission control system designed to maintain fuel economy and reduce vehicle emissions. Fuel is metered to intake system through a separate injector, mounted in intake manifold next to intake valve, for each cylinder. An Electronic Control Unit (ECU) monitors data from various sensors and controls such functions as fuel injector pulse width ("on" time), ignition timing and emission control devices.

Throttle Body Injection (TBI)

TBI system is a computerized fuel, ignition and emission control system designed to maintain fuel economy and reduce vehicle emissions. Fuel is metered to intake system through a single fuel injector, mounted to a throttle body on intake manifold. An Electronic Control Unit (ECU) monitors data from various sensors and controls such functions as fuel injector pulse width ("on" time), ignition timing and emission control devices.

ELECTRONIC CONTROL UNIT (ECU)

All Systems

If a system fault (malfunction) occurs, a built-in fail-safe mechanism within ECU controls fuel and ignition system functions according to preprogrammed values. This allows vehicle to be driven, but performance may not be optimal.

A self-diagnostic function allows ECU to store trouble codes in its memory. If a system fault occurs, CHECK ENGINE light will come on to inform driver of system problems and trouble code will be stored. For further self-diagnostic system information, see G - TESTS W/ CODES article in the ENGINE PERFORMANCE Section.

INPUT DEVICES (CARBURETED)

NOTE: Components are grouped into 2 categories. First category covers INPUT DEVICES, which control or produce voltage signals monitored by ECU. Second category covers OUTPUT SIGNALS, which are components controlled by ECU.

Vehicles are equipped with different combinations of input devices. Not all devices are used on all models. To determine input usage on a specific model, see L - WIRING DIAGRAMS article in the ENGINE PERFORMANCE Section. Available input signals include the following:

A/C-On Signal

When A/C is turned on, ECU receives voltage signal and activates idle-up system. See IDLE SPEED under FUEL SYSTEM (CARBURETED).

Coolant Temperature Sensor

E - THEORY/OPERATION

Article Text (p. 3)

1992 Subaru Legacy

For Canadian Tire 777 Niagara Street, Welland Ontario (905) 732-7501 Ext. 325

Copyright © 1997 Mitchell International

Monday, February 22, 1999 01:47PM

ECU applies reference voltage signal to this thermistor. Resistance value of sensor changes with variations in coolant temperature, causing reference voltage to increase or decrease. Sensor is equipped with 2 terminals. One terminal is used for ECU; other terminal is used for temperature gauge.

Crank Angle Sensor (Engine Speed Sensor)

Crank angle sensor is a magnetic pick-up coil sensing mechanism located in distributor. Sensor provides crankshaft angle and engine RPM inputs to ECU.

Electrical Loads

When headlights, heater blower or rear defogger are turned on, ECU receives voltage signal and activates idle-up system. See IDLE SPEED under FUEL SYSTEM (CARBURETED).

Oxygen (O₂) Sensor

Sensor generates voltage according to exhaust gas oxygen content. Voltage increases when oxygen content is low (rich), and decreases when oxygen content is high (lean). ECU determines air/fuel ratio based on voltage generated.

Vacuum/Pressure Sensor & Vacuum Line Control (VLC) Solenoid Valve

Detects changes in intake manifold vacuum and atmospheric pressure. Solenoid valve, located in line between intake manifold and vacuum/pressure sensor, receives voltage signal from ECU. With no voltage applied to solenoid valve, sensor monitors intake manifold vacuum. With voltage applied to solenoid valve, sensor monitors atmospheric pressure.

Vehicle Speed Sensor

ECU supplies voltage signal to one side of a tiny reed switch located in speedometer assembly. Speedometer cable revolutions open and close reed switch, providing ECU with continuity/no continuity input. ECU converts this signal to vehicle speed.

OUTPUT SIGNALS (CARBURETED)

NOTE: Vehicles are equipped with different combinations of computer-controlled components. Not all components listed below are used on every vehicle. For theory and operation of each output component, refer to indicated system.

Canister Purge Control Solenoid (CPCS) Valve

See FUEL EVAPORATIVE SYSTEM under EMISSION SYSTEMS.

CHECK ENGINE Light

See SELF-DIAGNOSTICS.

Coasting Fuel Cut (CFC) Solenoid

See FUEL CONTROL under FUEL SYSTEM (CARBURETED).

E - THEORY/OPERATION

Article Text (p. 4)

1992 Subaru Legacy

For Canadian Tire 777 Niagara Street, Welland Ontario (905) 732-7501 Ext. 325

Copyright © 1997 Mitchell International

Monday, February 22, 1999 01:47PM

Duty Solenoid Valve (DSV)

See FUEL CONTROL under FUEL SYSTEM (CARBURETED).

EGR Control Solenoid Valve

See EXHAUST GAS RECIRCULATION (EGR) under EMISSION SYSTEMS.

Float Bowl Vent Solenoid (FBVS)

See FUEL EVAPORATIVE SYSTEM under EMISSION SYSTEMS.

Fuel Pump Relay

See FUEL DELIVERY under FUEL SYSTEM (CARBURETED).

High Altitude Compensator (HAC) Solenoid Valve (Federal)

See FUEL CONTROL under FUEL SYSTEM (CARBURETED).

Idle-Up Control Solenoid Valve (ICSV)

See IDLE SPEED under FUEL SYSTEM (CARBURETED).

Power Transistor

See IGNITION SYSTEMS.

Self-Diagnostics

See SELF-DIAGNOSTICS.

Vacuum/Pressure Sensor & Vacuum Line Control (VLC) Solenoid Valve

See INPUT DEVICES (CARBURETED).

INPUT DEVICES (FUEL INJECTED)

NOTE: Components are grouped into 2 categories. First category is INPUT DEVICES, which are components that control or produce voltage signals monitored by ECU. Second category is OUTPUT SIGNALS, which are components controlled by ECU.

Vehicles are equipped with different combinations of input devices. Not all devices are used on all models. To determine input usage on a specific model, see L - WIRING DIAGRAMS article in the ENGINE PERFORMANCE Section. Available input signals include the following:

A/C Switch

Signals ECU of A/C operation.

Airflow Meter (Except Justy)

Hot-wire type airflow meter uses heat transfer between incoming air and a heating resistor (located in air intake), to convert air flowing into engine to an electric signal.

Air Temperature Sensor (Justy)

ECU applies reference voltage signal to air-temperature

E - THEORY/OPERATION

Article Text (p. 5)

1992 Subaru Legacy

For Canadian Tire 777 Niagara Street, Welland Ontario (905) 732-7501 Ext. 325

Copyright © 1997 Mitchell International

Monday, February 22, 1999 01:47PM

sensitive thermistor installed on air cleaner housing. Reference voltage increases and decreases with variations in air temperature.

Atmospheric Pressure Sensor

Sensor is a component part of ECU. ECU uses this signal to compensate for variations in altitude, which affect air/fuel mixture ratios.

Cam Angle Sensor (Legacy)

Sensor is located on camshaft support, on left cylinder bank. Pick-up coil acts as triggering device. Based on signals received from triggering device, ECU distinguishes No. 1 cylinder from other cylinders. ECU then uses these signals to trigger distributorless ignition system and fuel injectors.

Coolant Temperature Sensor

ECU applies reference voltage signal to thermistor. Resistance value of sensor changes with variations in coolant temperature, causing reference voltage to increase or decrease.

Crank Angle & TDC (Cylinder Identification) Sensor Assembly (Justy & Loyale)

Assembly is located in distributor. On Justy, pick-up coil acts as triggering device. On Loyale, optical sensing unit (light emitting diode) acts as triggering device. Based on signals received from triggering device, ECU determines crankshaft angle and identifies No. 1 cylinder. Based on these signals, ECU triggers ignition system and fuel injector(s).

Crank Angle Sensor (Legacy & SVX)

Sensor is installed on oil pump, at front center of cylinder block. Pick-up coil acts as triggering device. Based on signals received from triggering device, ECU determines crankshaft angle. Based on these signals, ECU triggers distributorless ignition system and fuel injectors.

Detonation (Knock) Sensor

Installed on cylinder block, this sensor responds to cylinder block vibrations resulting from detonation. If detonation occurs, a voltage is generated and sent to ECU. Based on voltage received, ECU retards spark timing until detonation stops.

Idle Switch

Switch signals ECU of closed throttle condition.

Inhibitor Switch (A/T)

Switch signals ECU of transmission gear position.

Neutral & Park Switches

Switch signals ECU of transmission gear position.

Oxygen (O2) Sensor

E - THEORY/OPERATION

Article Text (p. 6)

1992 Subaru Legacy

For Canadian Tire 777 Niagara Street, Welland Ontario (905) 732-7501 Ext. 325

Copyright © 1997 Mitchell International

Monday, February 22, 1999 01:47PM

Sensor generates voltage according to exhaust gas oxygen content. Voltage increases when oxygen content is low (rich), and decreases when oxygen content is high (lean). ECU determines air/fuel ratio based on voltage generated.

Pressure Switch (Turbo)

Mounted in front of body strut mount, this switch closes when intake manifold vacuum reaches about 2 in. Hg. This causes TURBO indicator light to glow, indicating turbocharging operation is in effect.

Throttle Sensor (Except Justy)

Throttle sensor contains a potentiometer (variable resistor) and an idle switch. Throttle position sensor sends ECU a potentiometer output signal corresponding to opening of throttle valve. Idle switch signal occurs when throttle is near idle position. ECU uses these signals to control air/fuel ratio during acceleration, deceleration and idling.

Throttle Switch (Justy)

This switch, attached to end of throttle shaft, informs ECU what throttle valve is closed, wide open (at least 50 degrees), or somewhere in between. This is NOT a variable resistor.

Vehicle Speed Sensor

ECU supplies voltage signal to one side of a tiny reed switch located in speedometer assembly. Speedometer cable revolutions open and close reed switch, providing ECU with continuity/no continuity input. ECU converts this signal to vehicle speed.

OUTPUT SIGNALS (FUEL INJECTED)

NOTE: Vehicles are equipped with different combinations of computer-controlled components. Not all components listed below are used on every vehicle. For theory and operation of each output component, refer to indicated system.

By-Pass Air Control Valve

See IDLE SPEED under FUEL SYSTEM (FUEL INJECTED).

Canister Purge Control (CPC) Solenoid Valve

See FUEL EVAPORATIVE SYSTEM under EMISSION SYSTEMS.

CHECK ENGINE Light

See SELF-DIAGNOSTICS.

Detonation (Knock) Sensor

See IGNITION TIMING CONTROL SYSTEM under IGNITION SYSTEMS.

EGR Control Solenoid Valve

See EXHAUST GAS RECIRCULATION (EGR) under EMISSION SYSTEMS.

E - THEORY/OPERATION

Article Text (p. 7)

1992 Subaru Legacy

For Canadian Tire 777 Niagara Street, Welland Ontario (905) 732-7501 Ext. 325

Copyright © 1997 Mitchell International

Monday, February 22, 1999 01:47PM

Fast Idle Control Device (FICD) Solenoid Valve
See IDLE SPEED under FUEL SYSTEM (FUEL INJECTED).

Fuel Injector(s)
See FUEL CONTROL (TBI) or FUEL CONTROL (PFI) under FUEL SYSTEM (FUEL INJECTED).

Fuel Pump Relay
See FUEL DELIVERY under FUEL SYSTEM (FUEL INJECTED).

Power Transistor
See IGNITION SYSTEMS.

Self-Diagnostics
See SELF-DIAGNOSTICS.

FUEL SYSTEM (CARBURETED)

FUEL DELIVERY

Fuel Pump

Electric fuel pump is located on crossmember, under center of floor. Flow rate of fuel changes as pressure varies on delivery side. This controls required quantity of fuel delivered.

Fuel Pump Relay

ECU provides power supply and ground for control circuit in fuel pump relay. When ignition is turned on with engine off, ECU energizes fuel pump relay for 3 seconds, activating fuel pump. After 3 seconds, unless ECU receives crank angle signal, ECU will stop energizing fuel pump relay.

FUEL CONTROL

Coasting Fuel Cut (CFC) Solenoid

Located in carburetor, this solenoid responds to voltage signal from ECU to adjust air/fuel mixture through idle circuit during deceleration. This prevents rich air/fuel mixtures during deceleration.

Duty Solenoid Valve (DSV)

Located in carburetor, this ECU-controlled solenoid cycles on and off to control air/fuel mixture ratio entering slow speed and main metering passages.

Electric Choke

When fuel pump relay is energized, voltage is applied to electric choke heater element. Voltage is applied to choke heater under same conditions as fuel pump. See FUEL PUMP RELAY under FUEL DELIVERY under FUEL SYSTEM (CARBURETED).

High Altitude Compensator (HAC) Solenoid Valve (Federal)

E - THEORY/OPERATION

Article Text (p. 8)

1992 Subaru Legacy

For Canadian Tire 777 Niagara Street, Welland Ontario (905) 732-7501 Ext. 325

Copyright © 1997 Mitchell International

Monday, February 22, 1999 01:47PM

To compensate for richer air/fuel mixtures at higher altitudes (26.38 in. Hg or less), HAC admits air into main metering passage. ECU energizes HAC solenoid when vacuum/pressure sensor indicates barometric pressure has reached predetermined specification. This opens valve, admitting more air into main metering passage.

Hot Idle Compensator

Bimetallic heat sensor in air filter housing allows more idle air through idle circuit at high engine temperatures.

IDLE SPEED

Idle-Up Control Solenoid Valve (ICSV)

ICSV compensates for decrease in engine RPM due to cold engine temperatures, increased electrical load (alternator loading) and A/C operation. See INPUT DEVICES (CARBURETED).

When ECU receives input signals indicating engine RPM has dropped, ECU energizes ICSV. ICSV controls vacuum supply to throttle opener diaphragm. When vacuum is applied to throttle opener diaphragm, throttle plate opens to compensate for a decrease in engine RPM.

FUEL SYSTEM (FUEL INJECTED)

FUEL DELIVERY

Fuel Pump

Impeller-type pump is used. On Justy, Legacy and SVX, fuel pump is located in fuel tank. On Loyale, fuel pump is mounted to underbody, near fuel tank.

On all models, fuel pump pressurizes fuel through in-line filter, to fuel injector rail. Fuel pump receives battery power through fuel pump relay.

Fuel Pump Relay

ECU energizes fuel pump relay based on inputs from ignition switch and ignition coil. During cranking, ignition switch cranking circuit supplies current to energize fuel pump relay. After engine starts and key is released to RUN position, ECU provides fuel pump relay ground. This activates fuel pump.

Fuel Pressure Regulator

Regulator maintains constant fuel system pressure by bleeding fuel at injector rail back to fuel tank. Intake manifold vacuum acts on regulator diaphragm to control position of bleed-off valve in regulator.

Fuel Pulsation Damper (Justy)

This device, located on fuel injector rail, absorbs fuel pressure pulsations.

FUEL CONTROL (TBI)

E - THEORY/OPERATION

Article Text (p. 9)

1992 Subaru Legacy

For Canadian Tire 777 Niagara Street, Welland Ontario (905) 732-7501 Ext. 325

Copyright © 1997 Mitchell International

Monday, February 22, 1999 01:47PM

Fuel Injector

Fuel is supplied to engine through a single throttle body injector valve mounted to intake manifold. ECU controls injectors' energized time (pulse width), which affects amount of fuel metered through injectors. ECU triggers injectors based on signals received from crank angle sensor.

FUEL CONTROL (PFI)

Fuel Injectors

Fuel is supplied to engine through injector valves located at intake manifold, near intake valve opening. ECU controls injectors' energized time (pulse width), which affects amount of fuel metered through injectors. ECU triggers injectors based on signals received from crank angle sensor.

IDLE SPEED

By-Pass Air Control Valve (Legacy)

Valve consists of coolant temperature-sensitive bimetallic valve and ECU-controlled duty solenoid. Bimetallic valve compensates for varying engine temperatures. ECU cycles duty solenoid on and off, regulating amount of air by-passing throttle valve. System compensates for idle speed decreases due to following conditions: cold engine temperatures, A/C operation and electrical loads (alternator loading). System also provides dashpot function to prevent rich air/fuel mixture ratios during deceleration.

By-Pass Air Control Valve (Loyale)

An air passage by-passing throttle valve is provided to control idle air intake volume. ECU cycles duty solenoid on and off, regulating amount of air by-passing throttle valve. System compensates for idle speed changes due to cold engine temperatures, A/C operation, and varying altitude.

Fast Idle Control Device (FICD) Solenoid Valve (Justy)

Valve is located in line between air filter housing and intake manifold. When A/C is turned on, ECU energizes solenoid valve. Solenoid valve will open, allowing fresh air to by-pass throttle valve through solenoid valve, into intake manifold.

Idle Speed Control (ISC) Solenoid Valve (Justy)

Valve is mounted on air filter housing, in line between air filter housing and intake manifold. At idle, ECU opens and closes solenoid valve. This allows fresh air to by-pass throttle valve through solenoid valve, into intake manifold.

Thermal Air Valve (Justy)

Coolant temperature-sensitive wax pellet valve allows idle air to by-pass throttle valve. This increases idle RPM during cold engine conditions.

E - THEORY/OPERATION

Article Text (p. 10)

1992 Subaru Legacy

For Canadian Tire 777 Niagara Street, Welland Ontario (905) 732-7501 Ext. 325

Copyright © 1997 Mitchell International

Monday, February 22, 1999 01:47PM

IGNITION SYSTEMS

POWER TRANSISTOR

Power transistor acts as primary current switching device for ignition system. When ECU signals power transistor base, primary current is allowed to flow to ground.

DISTRIBUTOR (MAGNETIC)

Justy

Magnetic pick-up coil sensing mechanism (crank angle sensor) in distributor signals ECU of crankshaft angle, and distinguishes between No. 1 cylinder and other cylinders. Based on these inputs, ECU signals power transistor base, allowing primary current to flow to ground through ignition coil.

On carbureted engines, ignition coil receives battery voltage from ignition switch. On PFI engines, ignition coil receives battery voltage from ignition relay. Ignition relay is energized with ignition switch in ON or START position.

DISTRIBUTOR (OPTICAL)

Loyale

Optical sensing unit (crank angle sensor) in distributor signals ECU of crankshaft angle and identifies No. 1 cylinder. System consists of distributor (crank angle sensor), ignition coil and power transistor.

Based on input from crank angle sensor, ECU signals base of power transistor. This allows primary current flow to ground. Ignition coil receives primary power supply when ignition coil relay is energized.

DISTRIBUTORLESS

Legacy

Distributorless ignition system is controlled by ECU. System consists of 2 ignition coils and a power transistor assembly. Power transistor assembly consists of 2 transistors, which control primary current path to ground for each ignition coil. One transistor controls primary path to ground for ignition coil, which fires cylinders No. 1 and 2. Other transistor controls primary path to ground for ignition coil, which fires cylinders No. 3 and 4.

Although each coil fires 2 plugs simultaneously, ignition takes place in only one cylinder, since other cylinder is on its exhaust stroke when plug fires. Based on input from crankshaft and crankshaft angle sensors, ECU signals base of appropriate power transistor. This allows primary current flow to ground. Ignition coils receive primary power supply when ignition coil relay is energized.

SVX

Distributorless ignition system is controlled by ECU. System

E - THEORY/OPERATION

Article Text (p. 11)

1992 Subaru Legacy

For Canadian Tire 777 Niagara Street, Welland Ontario (905) 732-7501 Ext. 325

Copyright © 1997 Mitchell International

Monday, February 22, 1999 01:47PM

consists of 6 ignition coils (mounted directly to spark plugs), 2 detonation (knock) sensors and 2 crank angle sensors.

ECU determines ignition timing based on signal from crank angle sensor and sends signal to ignitor to create a spark at cylinder which is judged to be at compression TDC.

IGNITION TIMING CONTROL SYSTEM

Detonation (Knock) Sensor

When engine knock (detonation) is present, a signal is generated by knock sensor and is sent to ECU. ECU retards spark timing until engine knocking stops, then gradually advances spark timing.

Ignition Timing Advance Control

On all models, ignition timing advance is controlled by ECU. Based on sensor input signals, ECU adjusts ignition timing to preprogrammed advance and retard specifications.

EMISSION SYSTEMS

PULSE AIR INJECTION SYSTEM

Justy (Carbureted)

Air injection system reduces exhaust emissions by oxidizing hydrocarbons (HC) and carbon monoxide (CO). System is composed of a one-way air suction valve (pulse air valve), air cleaner, various hoses and tubing.

Negative pressure from exhaust pulsation reaches suction valve through a suction pipe. This causes reeds in suction valve to open. Secondary (fresh) air from air cleaner is drawn into exhaust passages. When positive pressure is present in exhaust, reeds are closed to prevent reverse flow of exhaust gas.

EXHAUST GAS RECIRCULATION (EGR)

Justy (Carbureted), Loyale & SVX

EGR lowers oxides of nitrogen (NOx) exhaust emissions by admitting exhaust gases back into intake system. Exhaust gases lower peak combustion temperatures, which lowers NOx emissions.

EGR Control Solenoid Valve

EGR valve diaphragm receives operating vacuum through EGR control solenoid valve. ECU controls operation of EGR control solenoid valve.

FUEL EVAPORATIVE SYSTEM

Canister Purge Control Solenoid (CPCS) Valve

On models with Canister Purge Control Valve (CPCV), CPCS valve is located in vacuum signal line between CPCV and ported vacuum source. See CANISTER PURGE CONTROL VALVE (CPCV). Under certain conditions, ECU energizes CPCS valve. This allows ported vacuum signal

E - THEORY/OPERATION

Article Text (p. 12)

1992 Subaru Legacy

For Canadian Tire 777 Niagara Street, Welland Ontario (905) 732-7501 Ext. 325

Copyright © 1997 Mitchell International

Monday, February 22, 1999 01:47PM

to CPCV.

On models without CPV, CPC solenoid valve is located in purge line between canister and ported vacuum source. Under certain conditions, ECU energizes CPCV valve, allowing ported vacuum to purge canister.

Canister Purge Control Valve (CPCV)

Located on top of canister, vacuum-controlled valve opens and closes purge line between intake manifold and canister. CPCV valve remains closed at idle because ported vacuum activates its control diaphragm. When vacuum activates control diaphragm, purge line is opened, and stored vapors are free to be drawn into intake manifold.

Fuel Bowl Vent Solenoid (FBVS)

When ignition is off, this solenoid valve remains open to allow float bowl vapor to escape to canister. When ignition switch is in ON or START position, ECU energizes FBVS valve, blocking passage between float bowl and canister.

POSITIVE CRANKCASE VENTILATION (PCV)

PCV system draws crankcase blow-by, vapors and gases into combustion system rather than allowing them to escape into atmosphere. Crankcase gases mix with air/fuel mixture, and are burned in combustion chamber. When engine is running, manifold vacuum pulls PCV valve open, allowing crankcase fumes to enter intake manifold. If engine backfires, PCV valve is forced closed, stopping flow of gases. This prevents ignition of fumes in crankcase.

THERMOSTATIC AIR CLEANER (TAC)

Justy (Carbureted)

TAC reduces exhaust emissions by maintaining a uniform intake air temperature. System consists of an air cleaner housing, air stove on exhaust pipe, and air intake hose between air cleaner and manifold stove. Air cleaner housing contains an air control diaphragm, air control valve, temperature sensor valve, flame arrester, and connecting tubes and hoses.

SELF-DIAGNOSTICS

CHECK ENGINE LIGHT

All vehicles are equipped with a CHECK ENGINE light on instrument panel. Light illuminates when ignition switch is turned to ON position (bulb check), and when system malfunctions occur. For additional information, see G - TESTS W/ CODES article in the ENGINE PERFORMANCE Section.

END OF ARTICLE

F - BASIC TESTING

Article Text

1992 Subaru Legacy

For Canadian Tire 777 Niagara Street, Welland Ontario (905) 732-7501 Ext. 325

Copyright © 1997 Mitchell International

Monday, February 22, 1999 01:51PM

ARTICLE BEGINNING

1992 ENGINE PERFORMANCE

Subaru Basic Diagnostic Procedures

Legacy

INTRODUCTION

The following diagnostic steps help prevent overlooking a simple problem. This is also where to begin diagnosis for a no-start condition.

The first step in diagnosing any driveability problem is verifying the customer's complaint with a test drive under the conditions the problem reportedly occurred.

Before entering self-diagnostics, perform a careful and complete visual inspection. Most engine control problems result from mechanical breakdowns, poor electrical connections or damaged/misrouted vacuum hoses. Before condemning the computerized system, perform each test listed in this article.

NOTE: Perform all voltage tests with a Digital Volt-Ohmmeter (DVOM) with a minimum 10-megohm input impedance, unless stated otherwise in test procedure.

PRELIMINARY INSPECTION & ADJUSTMENTS

VISUAL INSPECTION

Visually inspect all electrical wiring for chafed, stretched, cut or pinched wiring. Ensure electrical connectors fit tightly and are not corroded. Ensure vacuum hoses are properly routed and are not pinched or cut. See M - VACUUM DIAGRAMS article in the ENGINE PERFORMANCE Section to verify routing and connections (if necessary). Inspect air induction system for possible vacuum leaks.

MECHANICAL INSPECTION

Compression

Check engine mechanical condition using a compression gauge, vacuum gauge or engine analyzer. See engine analyzer manual for specific instructions.

WARNING: DO NOT use ignition switch during compression tests on fuel injected vehicles. Use a remote starter to crank engine. Fuel injectors on many models are triggered by ignition switch during cranking mode, which can create a fire hazard or contaminate the engine's oiling system.

Exhaust System Backpressure

1) The exhaust system can be checked with a vacuum or

F - BASIC TESTING

Article Text (p. 2)

1992 Subaru Legacy

For Canadian Tire 777 Niagara Street, Welland Ontario (905) 732-7501 Ext. 325

Copyright © 1997 Mitchell International

Monday, February 22, 1999 01:51PM

pressure gauge. Remove O2 sensor or air injection check valve (if equipped).

2) Connect a 1-10 psi pressure gauge and operate engine at 2500 RPM. If exhaust system backpressure is greater than 1 3/4 - 2 psi, exhaust system or catalytic converter is plugged.

3) If a vacuum gauge is used, connect vacuum gauge hose to intake manifold vacuum port and start engine. Observe vacuum gauge. Open throttle part way and hold it steady. If vacuum gauge reading slowly drops after stabilizing, check exhaust system for restriction.

FUEL SYSTEM

FUEL PRESSURE

WARNING: Always relieve fuel pressure before disconnecting any fuel injection-related component. DO NOT allow fuel to contact engine or electrical components. If connecting fuel pressure gauge to fuel system without using a "T" connector, DO NOT operate fuel pump for more than a few seconds. Operating fuel pump for longer than a few seconds under this condition damages fuel pump.

Basic diagnosis of fuel system should begin by determining fuel system pressure. If fuel pump is inoperative, see appropriate FUEL PUMP CIRCUIT TEST chart under FUEL PUMP CIRCUIT TESTS.

Carbureted

Disconnect fuel hose from carburetor, and install pressure gauge using "T" connector. Turn ignition on. Fuel pump should run for 3 seconds and THEN stop. See REGULATED FUEL PRESSURE table.

Fuel-Injected

1) Disconnect fuel pump connector. Crank engine for at least 5 seconds. If engine starts, let it run until it stops. Disconnect fuel hose at pressure regulator and install fuel pressure gauge using "T" connector.

2) Start engine and check fuel pressure at idle. See REGULATED FUEL PRESSURE table. Ensure fuel pressure increases as engine speed increases.

REGULATED FUEL PRESSURE TABLE

Application	At Idle psi (kg/cm ²)
Legacy	36 (2.6)

IGNITION CHECKS

NOTE: Also see appropriate IGNITION CONTROL SYSTEM TEST chart

F - BASIC TESTING

Article Text (p. 3)

1992 Subaru Legacy

For Canadian Tire 777 Niagara Street, Welland Ontario (905) 732-7501 Ext. 325

Copyright © 1997 Mitchell International

Monday, February 22, 1999 01:51PM

under IGNITION CONTROL SYSTEM TESTS.

SPARK

Check for spark at spark plug wires using a spark tester. Check resistance of each spark plug wire. Replace wire if resistance is not within specification. See appropriate HIGH TENSION WIRE RESISTANCE table.

NOTE: Legacy is equipped with Direct Ignition Systems (DIS).

IGNITION COIL RESISTANCE

Legacy

1) Disconnect 3-wire connector from ignition coil assembly. Using an ohmmeter, check primary resistance between terminals No. 1 and 2 for one coil. See Fig. 1.

2) Check primary resistance between terminals No. 2 and 3 for remaining coil. Resistance should be as specified. See IGNITION COIL RESISTANCE table. If resistance is not as specified for each coil, replace ignition coil assembly.

3) To test secondary resistance, connect one ohmmeter lead to power at one end of coil. Connect remaining ohmmeter lead to tower at opposite end of same coil.

4) Repeat test for other coils. If resistance of each coil is not as specified, replace ignition coil assembly.

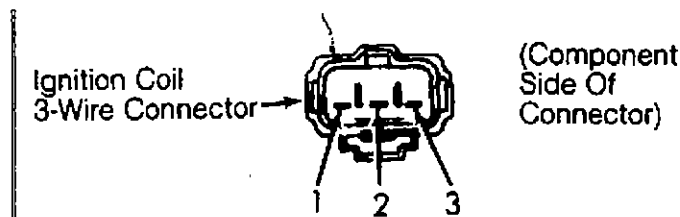

Fig. 1: Identifying Ignition Coil Connector Terminals (Legacy)
Courtesy of Subaru of America, Inc.

IGNITION COIL RESISTANCE TABLE (1)

Application	Primary	Secondary
Diamond	0.70	21,000
Hitachi	0.70	13,500

(1) - OHMS @ 68°F (20°C)

CRANK ANGLE & TDC SENSOR SIGNALS

NOTE: For crank angle and TDC sensor signal testing, see G - TESTS W/ CODES article in the ENGINE PERFORMANCE Section.

F - BASIC TESTING

Article Text (p. 4)

1992 Subaru Legacy

For Canadian Tire 777 Niagara Street, Welland Ontario (905) 732-7501 Ext. 325

Copyright © 1997 Mitchell International

Monday, February 22, 1999 01:51PM

IDLE SPEED & IGNITION TIMING

Ensure idle speed and ignition timing are set to specification. See IDLE SPEED SPECIFICATIONS and IGNITION TIMING tables. For adjustment procedures, see D - ADJUSTMENTS article in the ENGINE PERFORMANCE Section.

IDLE SPEED SPECIFICATIONS TABLE

Application	RPM
W/Accessories Off	600-800
W/Accessories On	800-900

IGNITION TIMING TABLE (1)

Application	Man. Trans.	Auto. Trans.
Non-Turbo	18-22 @ 700	12-28 @ 700
Turbo	7-23 @ 700	7-23 @ 700

(1) - Degrees BTDC @ RPM

WIRE COLORS

NOTE: Use WIRE COLOR ABBREVIATIONS table to identify wire colors in FUEL PUMP CIRCUIT TESTS and IGNITION CONTROL SYSTEM TESTS.

WIRE COLOR ABBREVIATIONS TABLE

Abbreviation	Color
BR	Black/Red
B	Black
Br	Brown
BW	Black/White
BY	Black/Yellow
G	Green
GB	Green/Black
GL	Green/Blue
GR	Green/Red
Gr	Gray
W	Green/White
GY	Green/Yellow
L	Blue
Lb	Light Blue
Lg	Light Green

F - BASIC TESTING

Article Text (p. 5)

1992 Subaru Legacy

For Canadian Tire 777 Niagara Street, Welland Ontario (905) 732-7501 Ext. 325

Copyright © 1997 Mitchell International

Monday, February 22, 1999 01:51PM

LgB	Light Green/Black
LR	Blue/Red
LW	Blue/White
LY	Blue/Yellow
Or	Orange
P	Pink
R	Red
RY	Red/Yellow
V	Violet
W	White
WB	White/Black
WR	White/Red
WY	White/Yellow
Y	Yellow
YL	Yellow/Blue
YR	Yellow/Red
YW	Yellow/White

SUMMARY

If no faults were found while performing BASIC DIAGNOSTIC PROCEDURES, proceed to G - TESTS W/ CODES article in the ENGINE PERFORMANCE Section. If no hard codes are found in self-diagnostics, go to H - TESTS W/O CODES article in the ENGINE PERFORMANCE Section for diagnosis by symptom (i.e., ROUGH IDLE, NO START, etc.) or intermittent diagnostic procedures.

FUEL PUMP CIRCUIT TESTS

G - TESTS W/CODES

Article Text

1992 Subaru Legacy

For Canadian Tire 777 Niagara Street, Welland Ontario (905) 732-7501 Ext. 325

Copyright © 1997 Mitchell International

Monday, February 22, 1999 01:55PM

ARTICLE BEGINNING

1992 ENGINE PERFORMANCE
Subaru Self-Diagnostics

Legacy

INTRODUCTION

NOTE: For any problems with abbreviations please see the ABBREVIATIONS article in the GENERAL INFORMATION Section.

If no faults were found while performing BASIC DIAGNOSTIC PROCEDURES proceed with self-diagnostics. If no fault codes or only pass codes are present after entering self-diagnostics, proceed to H - TESTS W/O CODES article in the ENGINE PERFORMANCE Section for diagnosis by symptom (i.e. ROUGH IDLE, NO START, etc.).

SELF-DIAGNOSTIC SYSTEM

Hard Failures

Hard failures cause CHECK ENGINE light to illuminate and remain on until problem is repaired. If light comes on and remains on (light may flash) during vehicle operation, cause of malfunction must be determined using diagnostic (code) charts. If a sensor fails, control unit will use a substitute value in its calculations to continue engine operation. In this condition, commonly known as limp-in mode, the vehicle runs but driveability will not be optimum.

Intermittent Failures

Intermittent failures may cause CHECK ENGINE light to flicker or illuminate and go out after the intermittent fault goes away. However, the corresponding trouble code will be retained in ECU memory. If related fault does not reoccur within a certain time frame, related trouble code will be erased from ECU memory. Intermittent failures may be caused by a sensor, connector or wiring related problems. See INTERMITTENTS in the H - TESTS W/O CODES article in the ENGINE PERFORMANCE Section.

RETRIEVING CODES

1) Enter specific test mode by connecting or disconnecting read memory and/or test mode connectors as shown in RELATIONSHIP BETWEEN MODES & CONNECTORS table. Connectors are located behind left side of dash. See Fig. 1.

2) Observe either CHECK ENGINE or O2 sensor monitor light. Note trouble codes, if any. Long illumination periods of 1.2 seconds designate the tens digit in the numbered codes. Short illumination periods of .2 second designate the ones digit in the numbered codes.

3) Tens and one digits are separated by a .03-second interval of non illumination. Example: 3 long flashes (1.2 seconds each),

G - TESTS W/CODES

Article Text (p. 2)

1992 Subaru Legacy

For Canadian Tire 777 Niagara Street, Welland Ontario (905) 732-7501 Ext. 325

Copyright © 1997 Mitchell International

Monday, February 22, 1999 01:55PM

followed by 5 short flashes (.02 second each) designate code 35.

4) Code is repeated after a break of 2 seconds, unless another code is present which will be displayed after the 2-second break. Once all codes have been displayed, sequence will repeat.

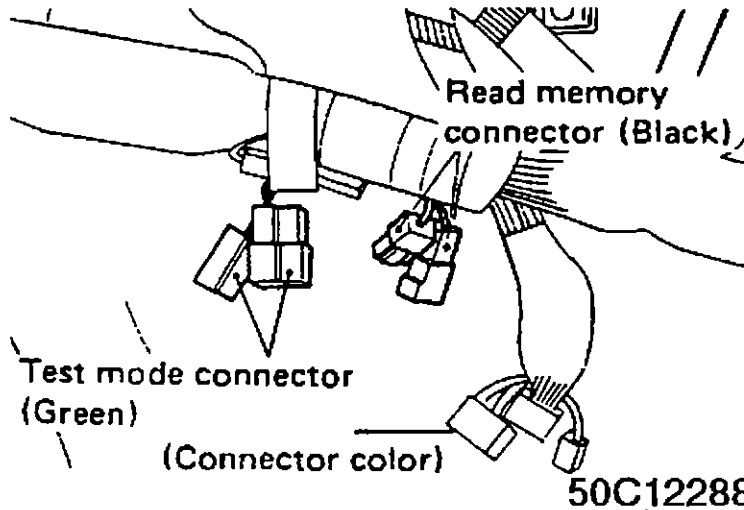

Fig. 1: Location of Read Memory & Test Mode Connectors
 Courtesy of Subaru of America, Inc.

RELATIONSHIP BETWEEN MODES & CONNECTORS TABLE

Mode	Read Memory Connector	Test Mode Connector
U-CHECK (1)	Disconnected	Disconnected
READ MEMORY (1)	Connected	Disconnected
D-CHECK (1)	Disconnected	Connected
CLEAR MEMORY (2)	Connected	Connected

(1) - Key on, engine off.

(2) - Key on, engine running.

SPECIFICATION CODES IDENTIFICATION

Specification codes are codes accessed with trouble code(s) from ECU. These codes determine transmission and vehicle emissions application.

SPECIFICATION CODES TABLE (1)

Code	Application
02	M/T (Non-Turbo), Canada & Fed.
03	M/T (Non-Turbo), Calif.
04	A/T (Non-Turbo), Canada & Fed.
05	A/T (Non-Turbo), Calif.
05	M/T (Turbo), Canada & Fed.

G - TESTS W/CODES

Article Text (p. 3)

1992 Subaru Legacy

For Canadian Tire 777 Niagara Street, Welland Ontario (905) 732-7501 Ext. 325

Copyright © 1997 Mitchell International

Monday, February 22, 1999 01:55PM

06 M/T (Turbo), Calif.
07 A/T (Turbo), Canada & Fed.
08 A/T (Turbo), Calif.

(1) - Specification codes are accessed with trouble codes through CHECK ENGINE or O2 monitor light.

TROUBLE CODE ID

LEGACY TROUBLE CODE IDENTIFICATION TABLE

Code	Circuit Affected	Probable Cause
11	Crank Angle Sensor	No Reference Signal
12	Starter Switch	Open/Short Circuit
13	Cam Angle Sensor	No Reference Signal
14	Fuel Injector No. 1	Inoperative Fuel Injector
15	Fuel Injector No. 2	Inoperative Fuel Injector
16	Fuel Injector No. 3	Inoperative Fuel Injector
17	Fuel Injector No. 4	Inoperative Fuel Injector
21	Coolant Temperature Sensor	Open/Short Circuit
22	Knock Sensor	Open/Short Circuit
23	Airflow Meter Circuit	Open/Short Circuit
24	By-Pass Air Ctrl Valve	Inoperative Air Ctrl Valve
31	Throttle Position Sensor	Open/Short Circuit
32	Oxygen (O2) Sensor	Abnormal Sensor Signal
33	Vehicle Speed Sensor	No Reference Signal
35	Purge Control Solenoid Valve	Open/Short Circuit
41	Air/Fuel Ratio Control Sys	Faulty Learning Control Function
42	Idle Switch	Abnormal Reference Signal
44	Wastegate Duty Solenoid (Turbo)	Open/Short Circuit
45	Atmospheric Pressure Sensor (1)	Faulty Sensor
45	Pressure Sensor Duty Solenoid	Valve Inoperative
49	Airflow Sensor	Use of Improper Airflow Sensor
51	Neutral Safety Switch (M/T)	Open/Short Circuit
51	Inhibitor Switch (A/T)	Open/Short Circuit
52	Parking Brake Switch (A/T)	Open/Short Circuit

(1) - Non-turbo models.

CLEARING CODES

After malfunction has been corrected, trouble code will clear from memory when CLEAR MEMORY mode is accessed. Unless all items check okay in D-CHECK mode, memory will not be cleared. See RELATIONSHIP BETWEEN MODES & CONNECTORS table.

ECM LOCATION

G - TESTS W/CODES

Article Text (p. 4)

1992 Subaru Legacy

For Canadian Tire 777 Niagara Street, Welland Ontario (905) 732-7501 Ext. 325

Copyright © 1997 Mitchell International

Monday, February 22, 1999 01:55PM

Legacy ECM is located behind the left dash panel.

CODE CHART WIRE COLORS

WIRE COLOR ABBREVIATIONS USED IN CODE CHARTS TABLE

Abbreviation	Color
BR	Black/Red
B	Black
Br	Brown
BW	Black/White
BY	Black/Yellow
G	Green
GB	Green/Black
GL	Green/Blue
GR	Green/Red
Gr	Gray
GW	Green/White
GY	Green/Yellow
L	Blue
Lg	Light Blue
LgB	Light Green/Black
LR	Blue/Red
LW	Blue/White
LY	Blue/Yellow
Or	Orange
P	Pink
R	Red
RY	Red/Yellow
V	Violet
W	White
WB	White/Black
WR	White/Red
WY	White/Yellow
Y	Yellow
YL	Yellow/Blue
YR	Yellow/Red
YW	Yellow/White

DIAGNOSTIC CODE CHARTS

NOTE: The following diagnostic flow charts and mini-schematics are courtesy of Subaru of America, Inc.

OPERATION OF SELF-DIAGNOSTIC SYSTEM IN "NO TROUBLE" CONDITION

OPERATION OF SELF-DIAGNOSTIC SYSTEM - NO TROUBLE MENU TABLE (1)

G - TESTS W/CODES

Article Text (p. 5)

1992 Subaru Legacy

For Canadian Tire 777 Niagara Street, Welland Ontario (905) 732-7501 Ext. 325

Copyright © 1997 Mitchell International

Monday, February 22, 1999 01:55PM

Mode	Read Memory Connector	Test Mode Connector	Engine Condition	Check Engine Light
U-check	X	X	Key ON (Engine OFF)	ON
			Engine ON	OFF
Read Memory	O	X	Key ON (Engine OFF)	Blink
			Engine ON	ON
D-check	X	O	Key ON (Engine OFF)	ON
			Engine ON	OFF To Blink (2)
Clear Memory	O	O	Key ON (Engine OFF)	ON
			Engine ON	OFF To Blink (2)

(1) - O: Connect X: Disconnect

(2) - When the engine operates at a speed greater than 2,000 rpm for more than 40 seconds, the check engine light blinks. However, when all check items check out "OK", even before the 40 seconds is reached, the check engine light blinks.

OPERATION OF SELF-DIAGNOSTIC SYSTEM - "TROUBLE" MENU

OPERATION OF SELF-DIAGNOSTIC SYSTEM - TROUBLE MENU TABLE (1)

Mode	Read Memory Connector	Test Mode Connector	Engine Condition	Check Engine Light
U-check	X	X	Key ON	ON
Read Memory	O	X	Key ON	Trouble code (memory)
D-check	X	O	Engine ON	Trouble code (2)
Clear Memory	O	O	Engine ON	Trouble code (2)

(1) - O: Connect X: Disconnect

G - TESTS W/CODES

Article Text (p. 6)

1992 Subaru Legacy

For Canadian Tire 777 Niagara Street, Welland Ontario (905) 732-7501 Ext. 325

Copyright © 1997 Mitchell International

Monday, February 22, 1999 01:56PM

(2) - When the engine operates at a speed greater than 2,000 rpm for more than 40 seconds, a trouble code is emitted.

READ MEMORY MODE

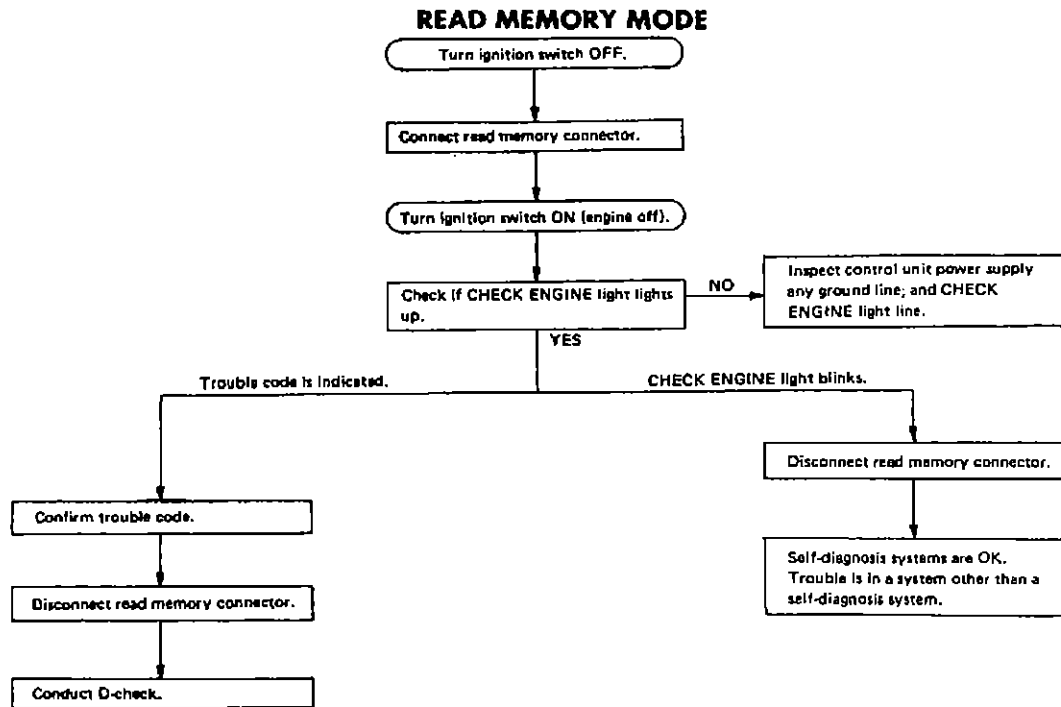

Fig. 2: Flow Chart - Read Memory Mode

D-CHECK MODE

G - TESTS W/CODES

Article Text (p. 7)

1992 Subaru Legacy

For Canadian Tire 777 Niagara Street, Welland Ontario (905) 732-7501 Ext. 325

Copyright © 1997 Mitchell International

Monday, February 22, 1999 01:56PM

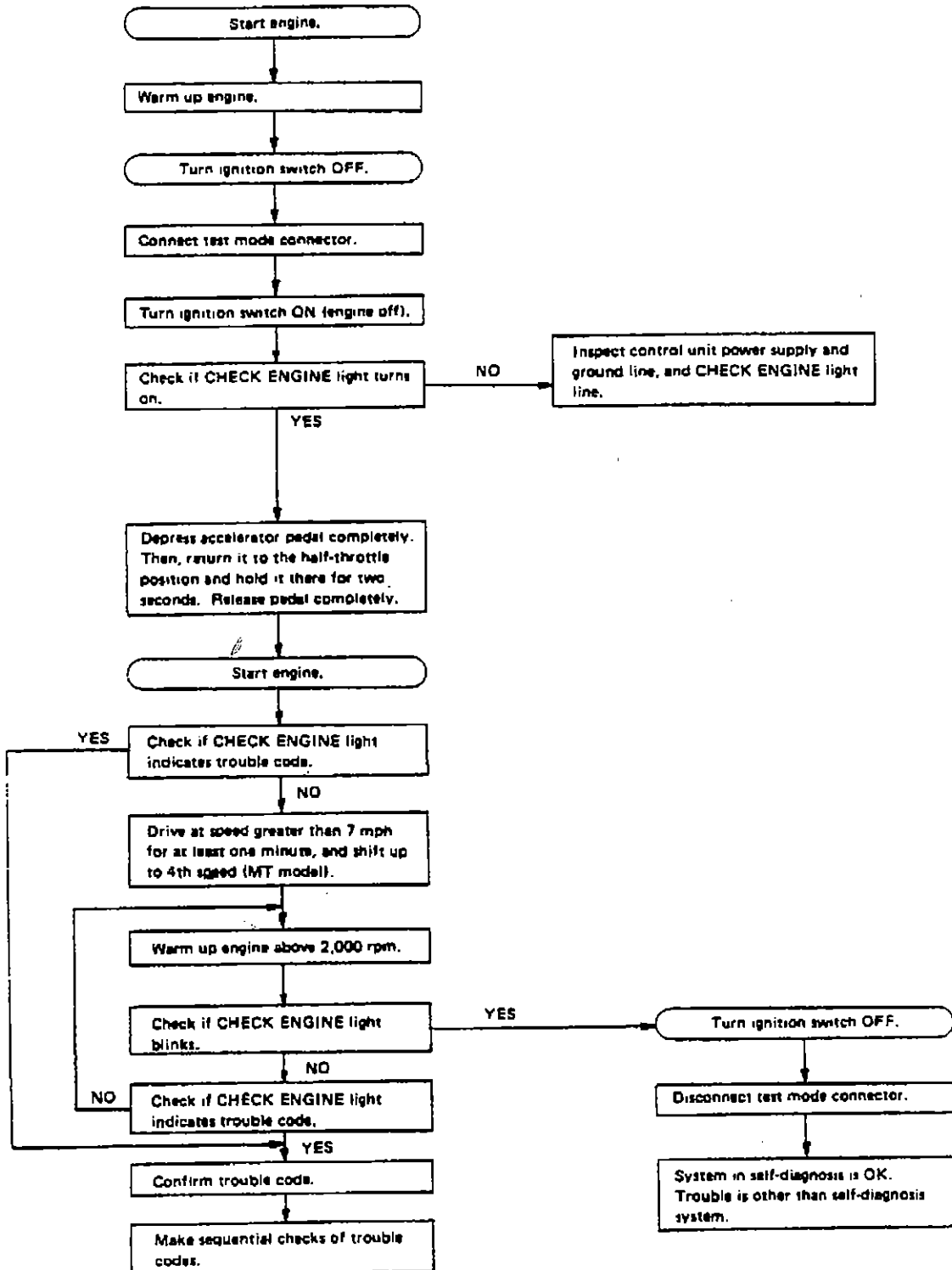

Fig. 3: Flow Chart - D-Check Mode

CLEAR MEMORY MODE

G - TESTS W/CODES

Article Text (p. 8)

1992 Subaru Legacy

For Canadian Tire 777 Niagara Street, Welland Ontario (905) 732-7501 Ext. 325

Copyright © 1997 Mitchell International

Monday, February 22, 1999 01:56PM

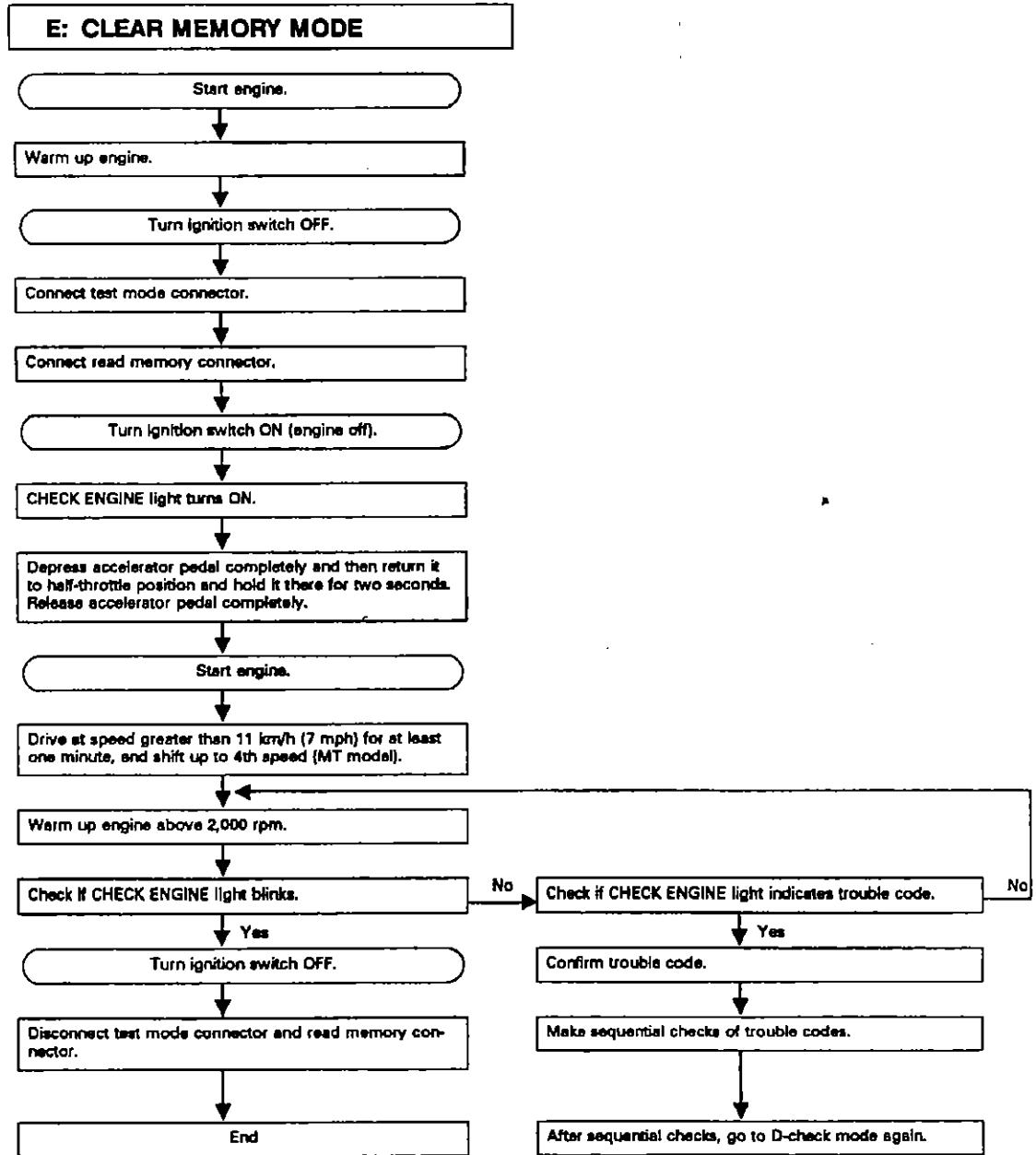

92D26990

Fig. 4: Flow Chart - Clear Memory Mode

CODE 11, CRANK ANGLE SENSOR

G - TESTS W/CODES

Article Text (p. 9)

1992 Subaru Legacy

For Canadian Tire 777 Niagara Street, Welland Ontario (905) 732-7501 Ext. 325

Copyright © 1997 Mitchell International

Monday, February 22, 1999 01:56PM

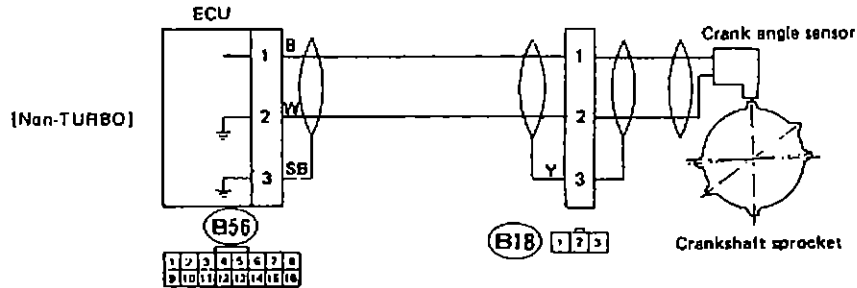
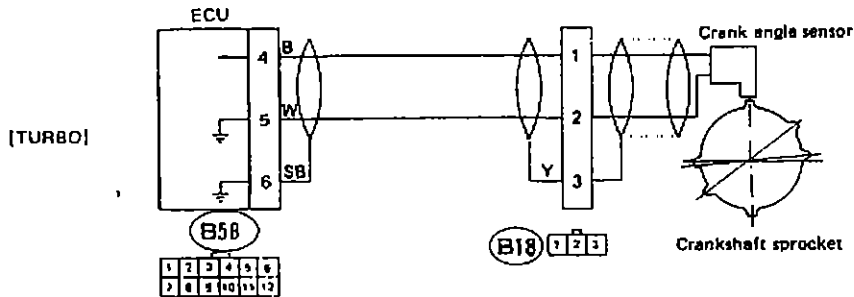

Fig. 5: Schematic - Code 11, Crank Angle Sensor (Non-Turbo)



TRUBLE SYMPTOM:

Fig. 6: Schematic - Code 11, Crank Angle Sensor (Turbo)

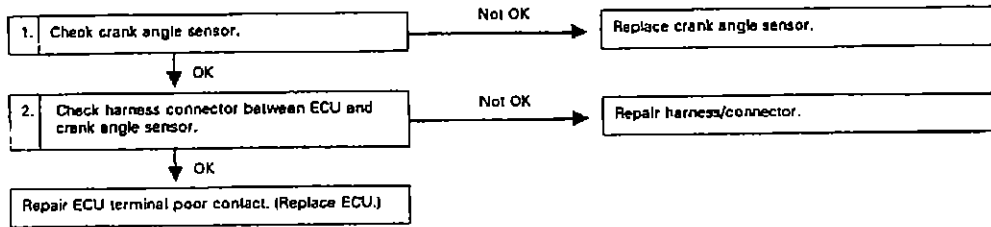

Fig. 7: Flow Chart - Code 11, Crank Angle Sensor

CODE 12, STARTER SWITCH

G - TESTS W/CODES

Article Text (p. 10)

1992 Subaru Legacy

For Canadian Tire 777 Niagara Street, Welland Ontario (905) 732-7501 Ext. 325

Copyright © 1997 Mitchell International

Monday, February 22, 1999 01:56PM

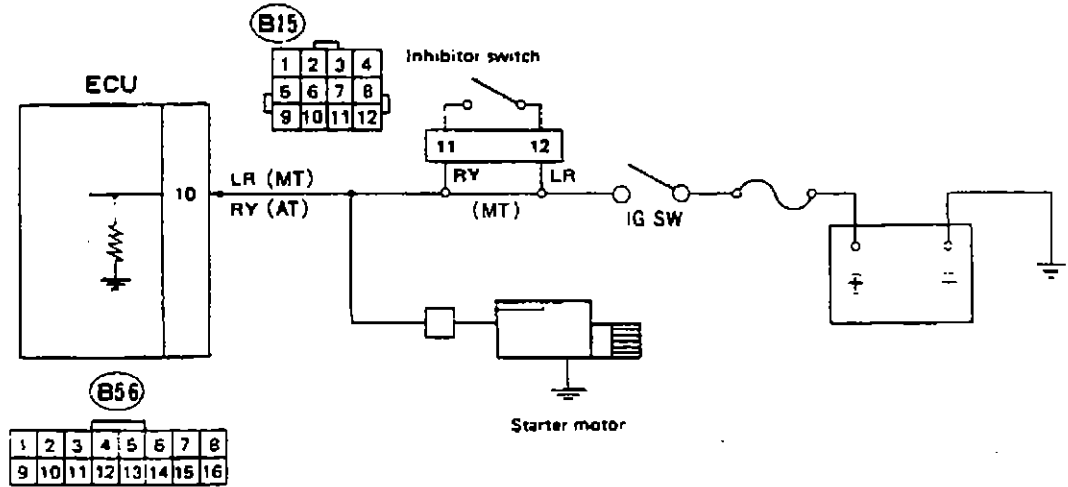

Fig. 8: Schematic - Code 12, Starter Switch

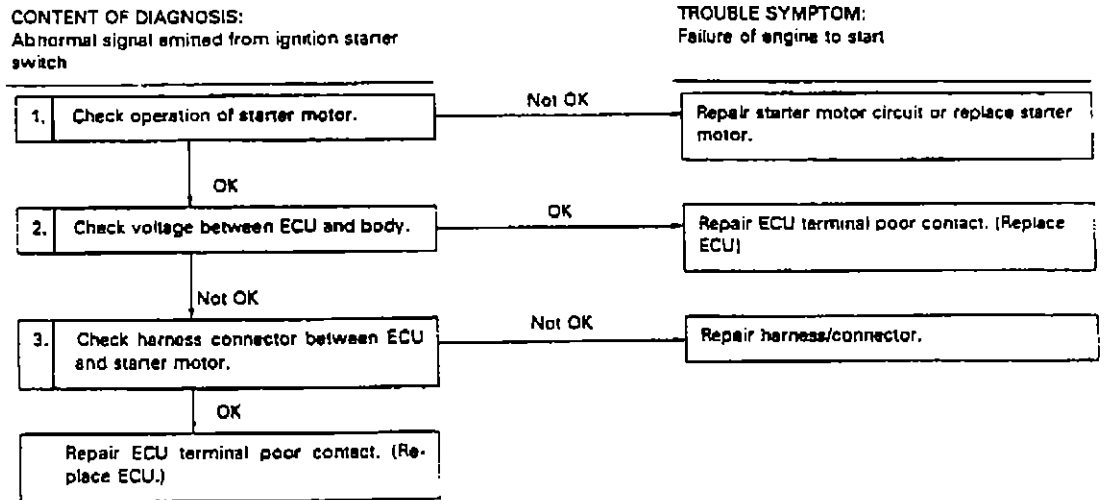

Fig. 9: Flow Chart - Code 12, Starter Switch

CODE 13, CAM ANGLE SENSOR

G - TESTS W/CODES

Article Text (p. 11)

1992 Subaru Legacy

For Canadian Tire 777 Niagara Street, Welland Ontario (905) 732-7501 Ext. 325

Copyright © 1997 Mitchell International

Monday, February 22, 1999 01:56PM

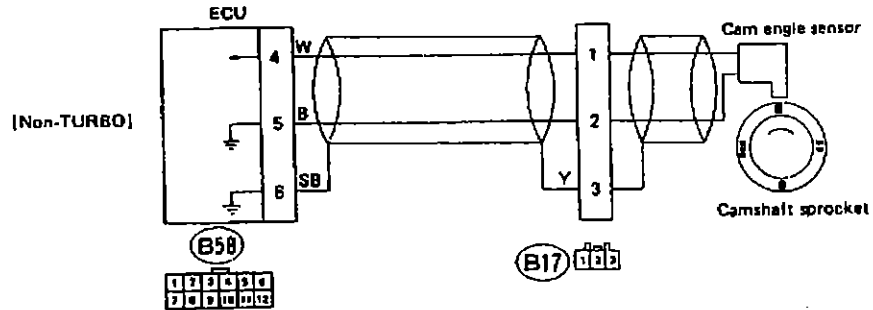

Fig. 10: Schematic - Code 13, CAM Angle Sensor (Non-Turbo)

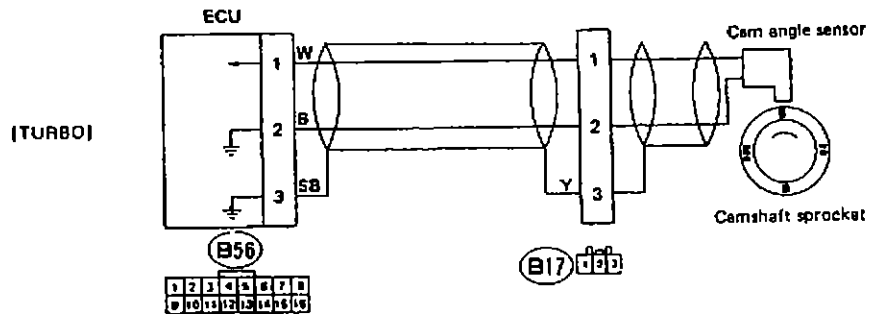

Fig. 11: Schematic - Code 13, CAM Angle Sensor (Turbo)

CONTENT OF DIAGNOSIS:
No signal entered from cam angle sensor, but signal (corresponding to at least two rotations of cam) entered from crank angle sensor

TROUBLE SYMPTOM:
• Engine stall
• Failure of engine to start

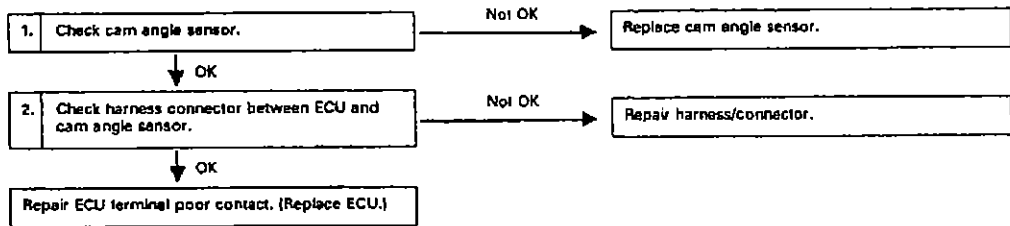

Fig. 12: Flow Chart - Code 13, CAM Angle Sensor

CODES 14, 15, 16 & 17, FUEL INJECTORS

G - TESTS W/CODES

Article Text (p. 12)

1992 Subaru Legacy

For Canadian Tire 777 Niagara Street, Welland Ontario (905) 732-7501 Ext. 325

Copyright © 1997 Mitchell International

Monday, February 22, 1999 01:56PM

CODES 14, 15, 16 & 17, FUEL INJECTORS

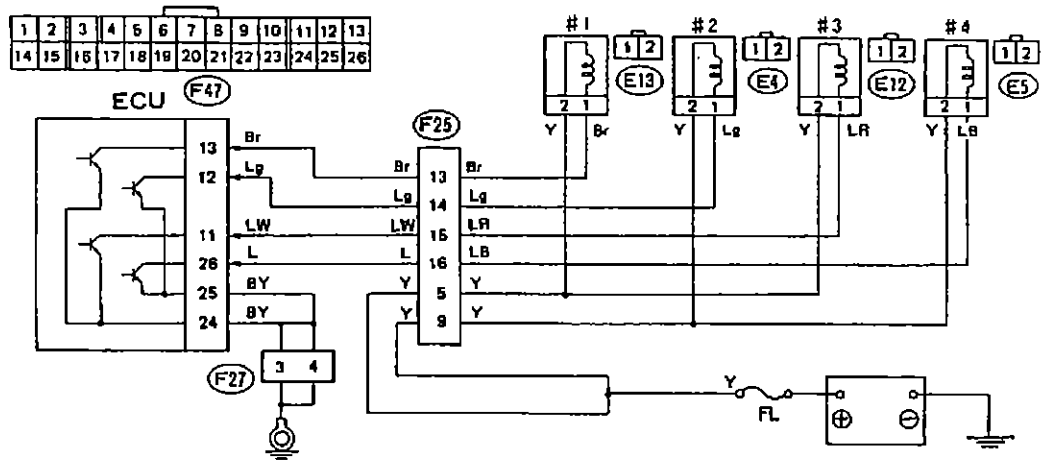

Fig. 13: Schematic - Codes 14, 15, 16 & 17, Fuel Injectors

CONTENT OF DIAGNOSIS:
Fuel injector inoperative

TROUBLE SYMPTOM:
• Engine stall
• Erroneous idling
• Rough driving

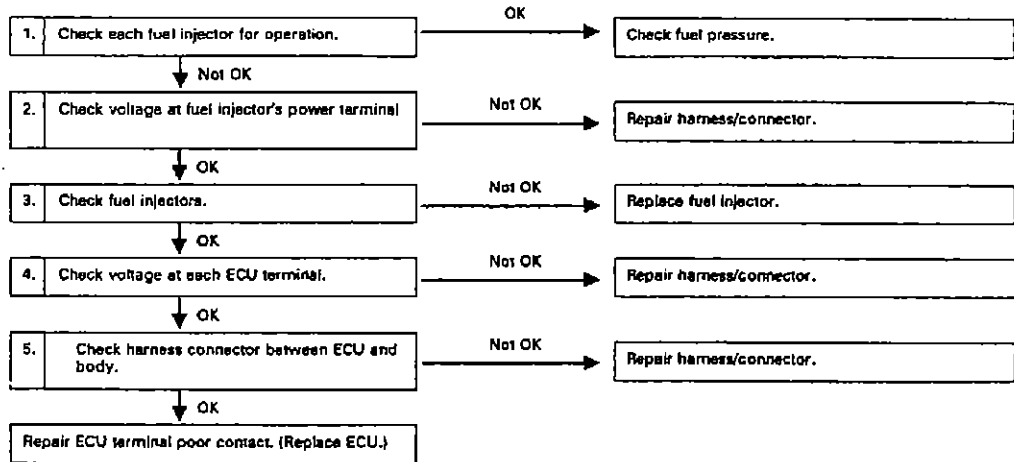

Fig. 14: Flow Chart - Codes 14, 15, 16 & 17, Fuel Injectors

CODE 21, COOLANT (WATER) TEMPERATURE SENSOR

G - TESTS W/CODES

Article Text (p. 13)

1992 Subaru Legacy

For Canadian Tire 777 Niagara Street, Welland Ontario (905) 732-7501 Ext. 325

Copyright © 1997 Mitchell International

Monday, February 22, 1999 01:56PM

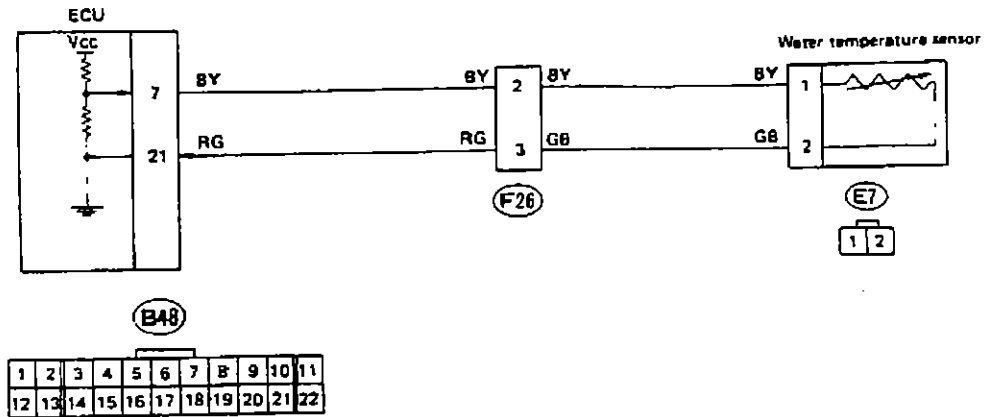

Fig. 15: Schematic - Code 21, Coolant (Water) Temperature Sensor

CONTENT OF DIAGNOSIS:
Abnormal signal emitted from water temperature sensor

TROUBLE SYMPTOM:

- Hard to start
- Erroneous idling
- Poor driving performance

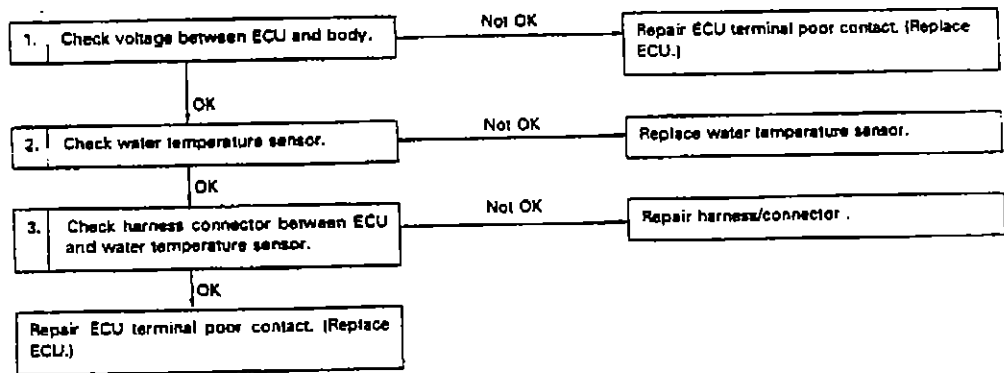

Fig. 16: Flow Chart - Code 21, Coolant (Water) Temperature Sensor

CODE 22, KNOCK SENSOR

G - TESTS W/CODES

Article Text (p. 14)

1992 Subaru Legacy

For Canadian Tire 777 Niagara Street, Welland Ontario (905) 732-7501 Ext. 325

Copyright © 1997 Mitchell International

Monday, February 22, 1999 01:56PM

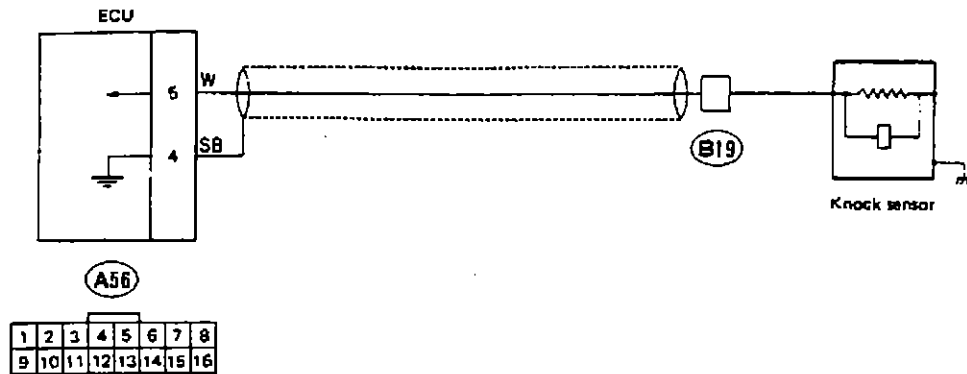

Fig. 17: Schematic - Code 22, Knock Sensor

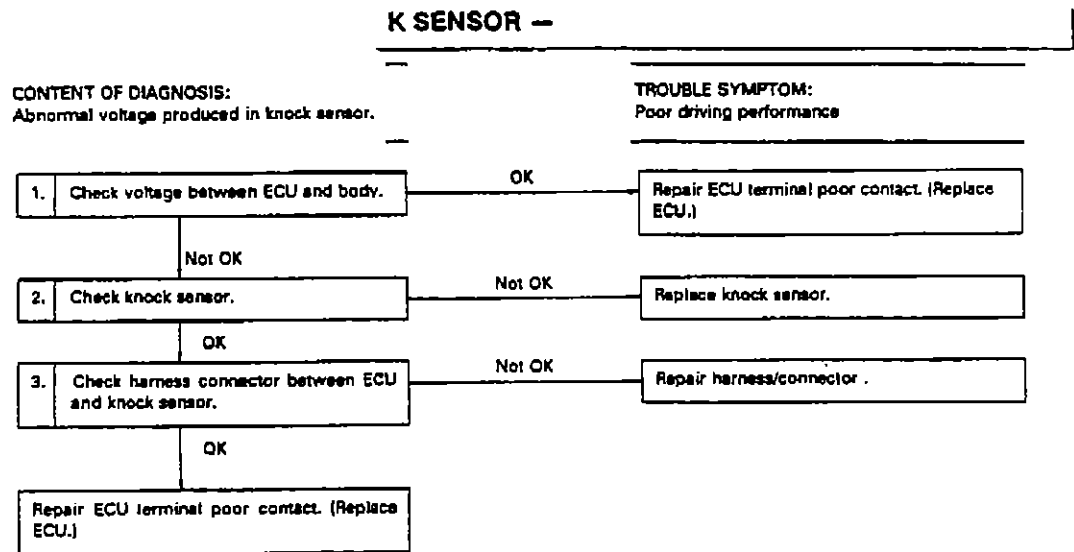

Fig. 18: Flow Chart - Code 22, Knock Sensor

CODE 23, AIRFLOW METER CIRCUIT

G - TESTS W/CODES

Article Text (p. 15)

1992 Subaru Legacy

For Canadian Tire 777 Niagara Street, Welland Ontario (905) 732-7501 Ext. 325

Copyright © 1997 Mitchell International

Monday, February 22, 1999 01:56PM

CONTENT OF DIAGNOSIS:
Abnormal voltage input entered from air flow sensor

TROUBLE SYMPTOM:

- Erroneous idling
- Engine stall
- Poor driving performance

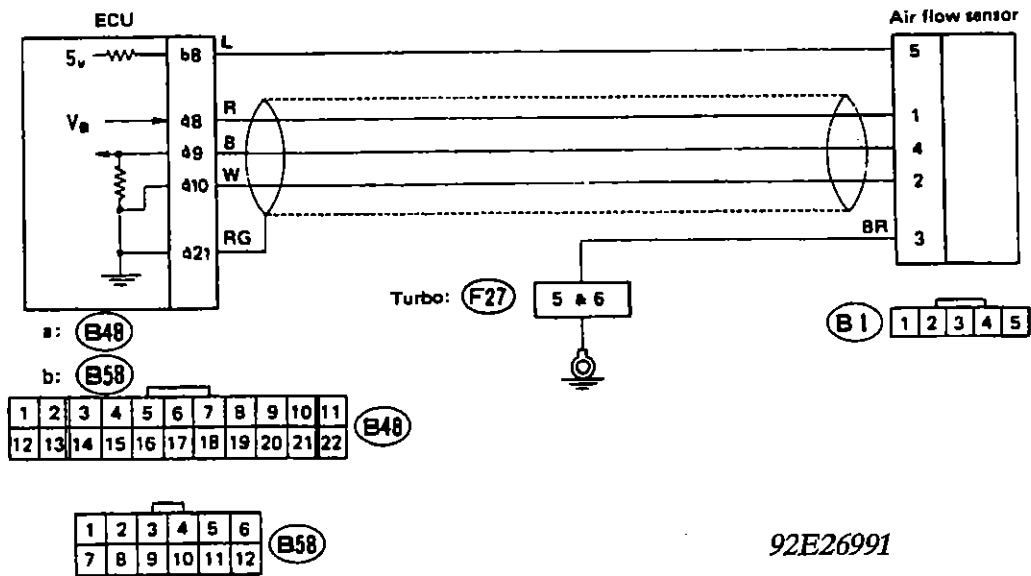
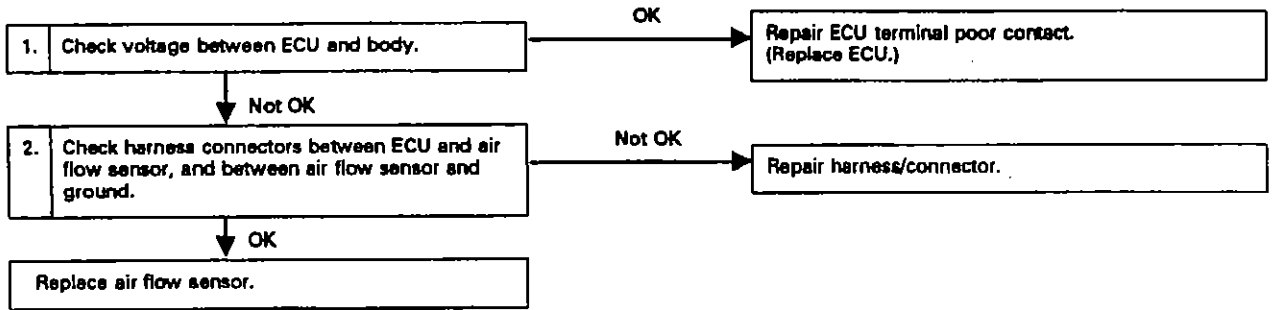

92E26991

Fig. 19: Schematic - Code 23, Airflow Sensor Circuit

CONTENT OF DIAGNOSIS:
Abnormal voltage input entered from air flow sensor

TROUBLE SYMPTOM:

- Erroneous idling
- Engine stall
- Poor driving performance

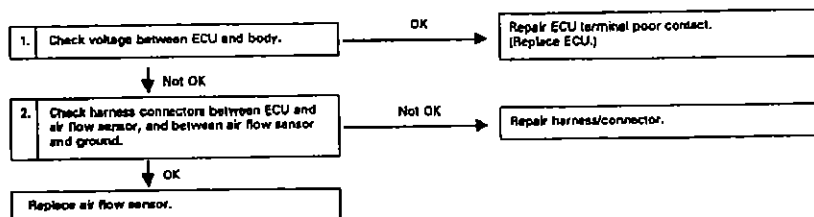

Fig. 20: Flow Chart - Code 23, Airflow Sensor Circuit

G - TESTS W/CODES

Article Text (p. 16)

1992 Subaru Legacy

For Canadian Tire 777 Niagara Street, Welland Ontario (905) 732-7501 Ext. 325

Copyright © 1997 Mitchell International

Monday, February 22, 1999 01:56PM

CODE 24, BY-PASS AIR CONTROL VALVE

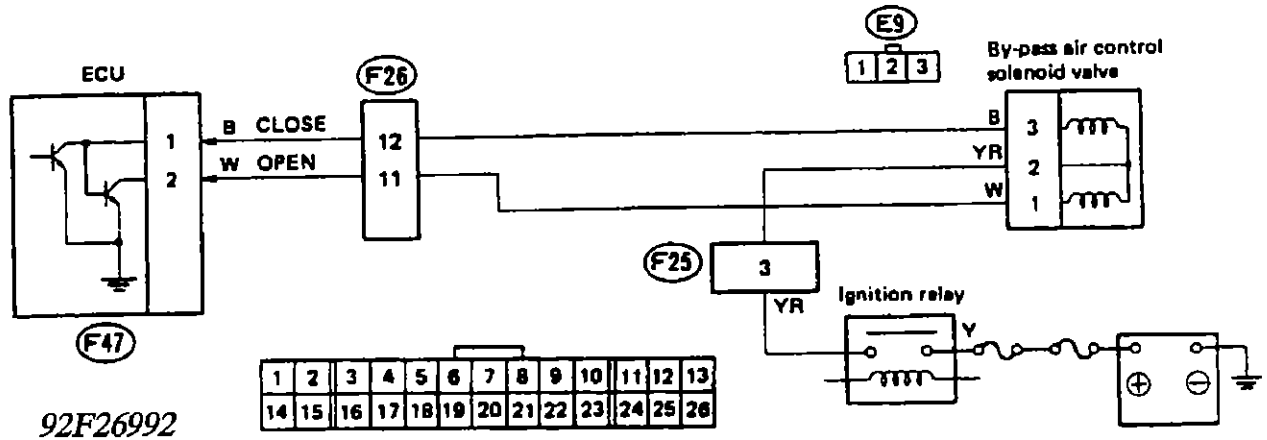
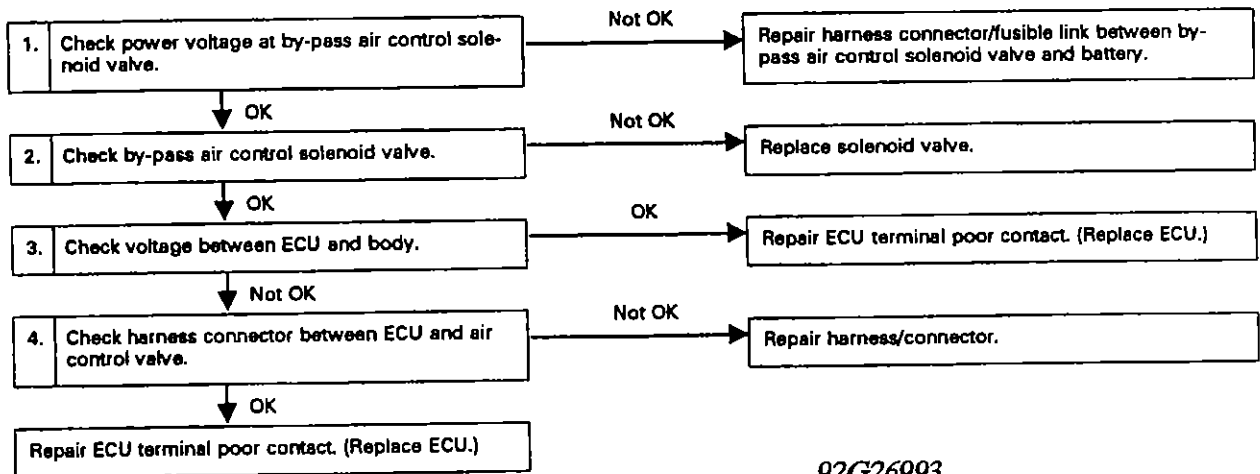

Fig. 21: Schematic - Code 24, By-Pass Air Control Valve

CONTENT OF DIAGNOSIS:
Solenoid valve inoperative

TROUBLE SYMPTOM:
 • Erroneous idling
 • Engine stall
 • Engine breathing



92G26993

Fig. 22: Flow Chart - Code 24, By-Pass Air Control Valve

CODE 31, THROTTLE POSITION SENSOR

G - TESTS W/CODES

Article Text (p. 17)

1992 Subaru Legacy

For Canadian Tire 777 Niagara Street, Welland Ontario (905) 732-7501 Ext. 325

Copyright © 1997 Mitchell International

Monday, February 22, 1999 01:56PM

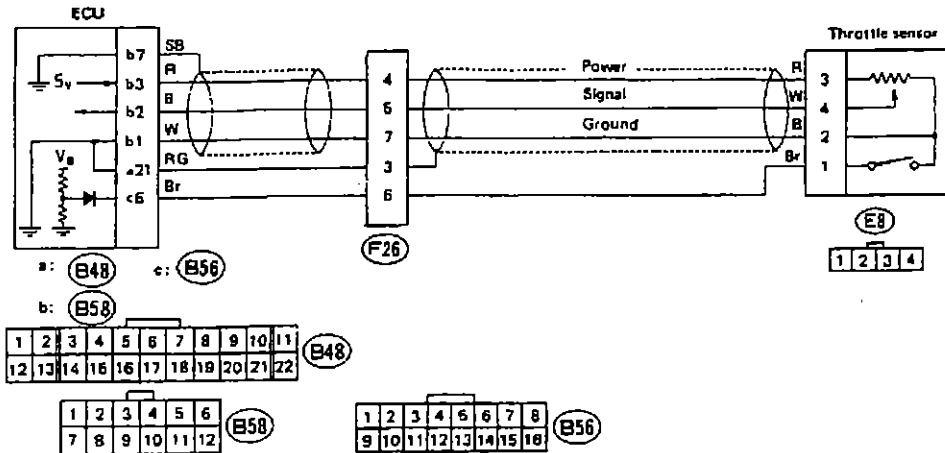

Fig. 23: Schematic - Code 31, Throttle Position Sensor

CONTENT OF DIAGNOSIS:
Abnormal voltage input entered from throttle sensor.

TRUBLE SYMPTOM:
• Erroneous idling
• Engine stall
• Poor driving performance

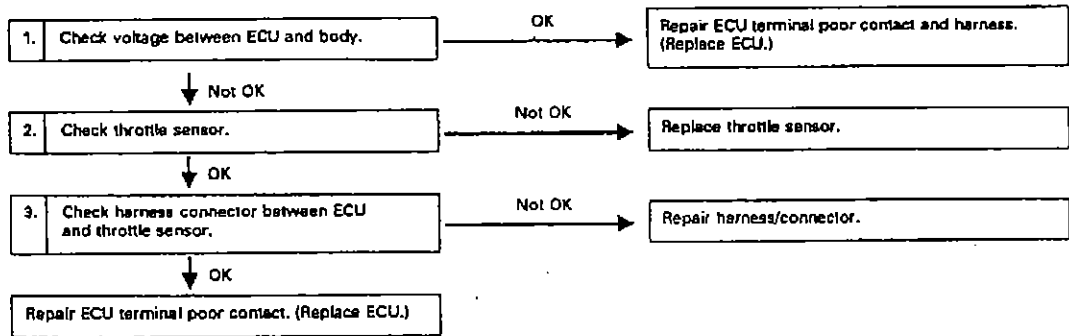

Fig. 24: Flow Chart - Code 31, Throttle Position Sensor

CODE 32, OXYGEN (O2) SENSOR

G - TESTS W/CODES

Article Text (p. 18)

1992 Subaru Legacy

For Canadian Tire 777 Niagara Street, Welland Ontario (905) 732-7501 Ext. 325

Copyright © 1997 Mitchell International

Monday, February 22, 1999 01:56PM

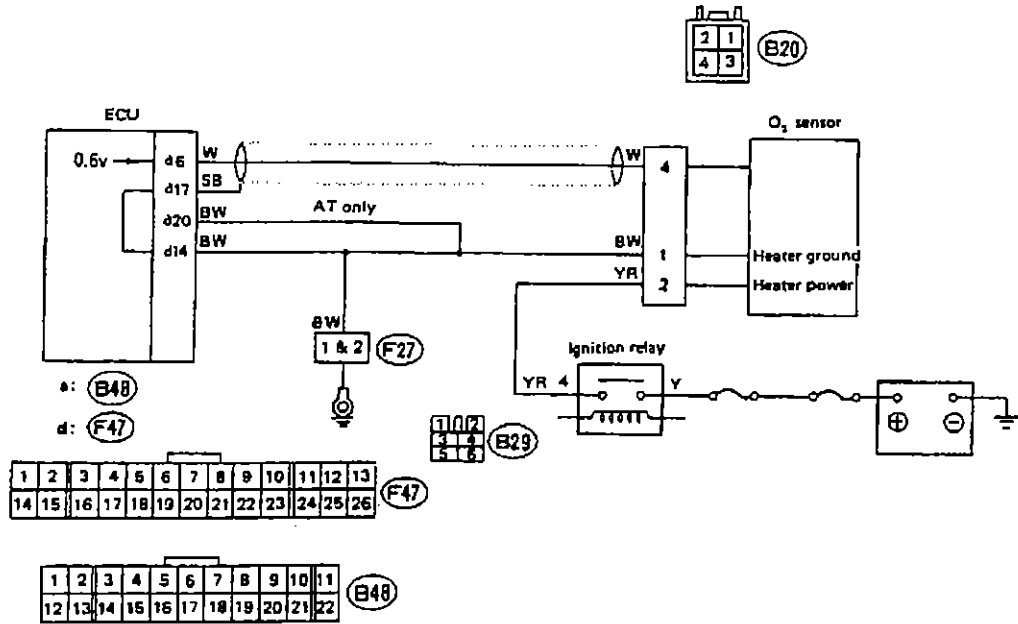

Fig. 25: Schematic - Code 32, Oxygen (O2) Sensor

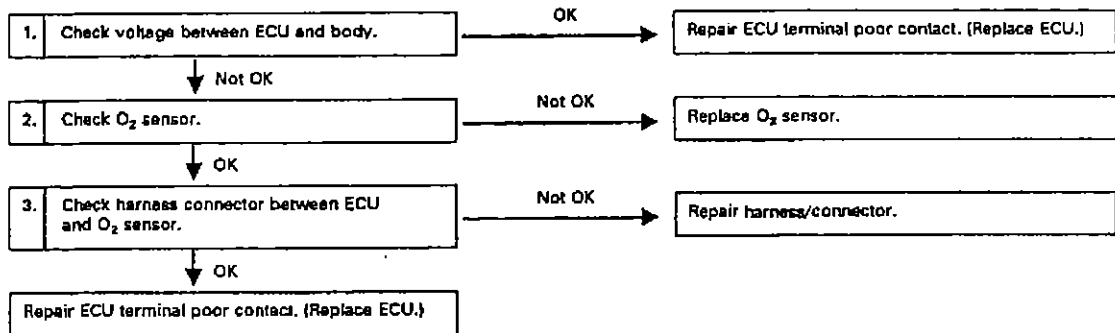

Fig. 26: Flow Chart - Code 32, Oxygen (O2) Sensor

CODE 33, VEHICLE SPEED SENSOR NO. 2

G - TESTS W/CODES

Article Text (p. 19)

1992 Subaru Legacy

For Canadian Tire 777 Niagara Street, Welland Ontario (905) 732-7501 Ext. 325

Copyright © 1997 Mitchell International

Monday, February 22, 1999 01:56PM

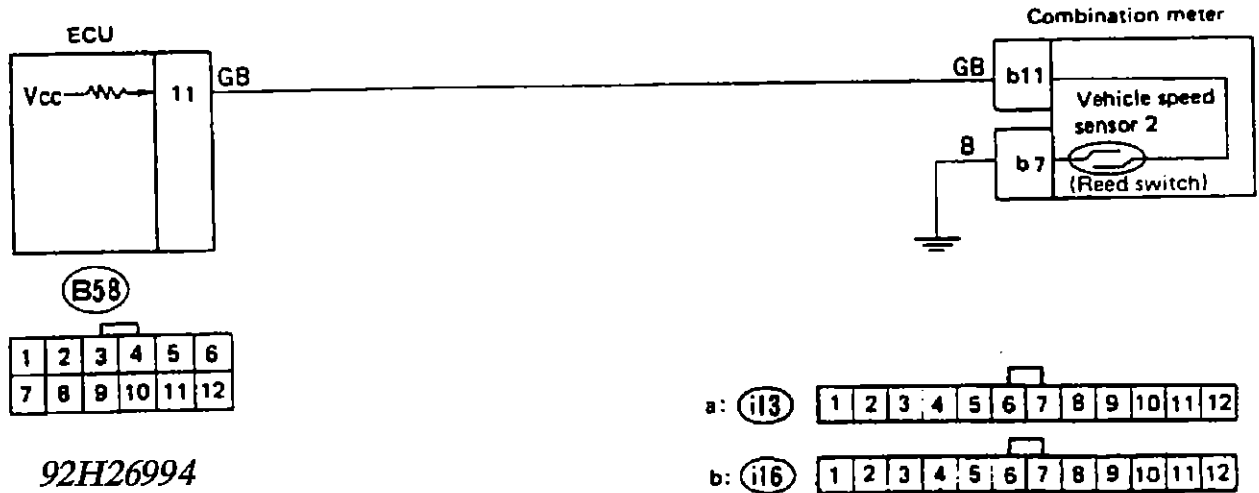

92H26994

Fig. 27: Schematic - Code 33, Vehicle Speed Sensor No. 2

CONTENT OF DIAGNOSIS:

Abnormal voltage input entered from vehicle speed sensor 2

TROUBLE SYMPTOM:

- Erroneous idling
- Engine stall
- Poor driving performance

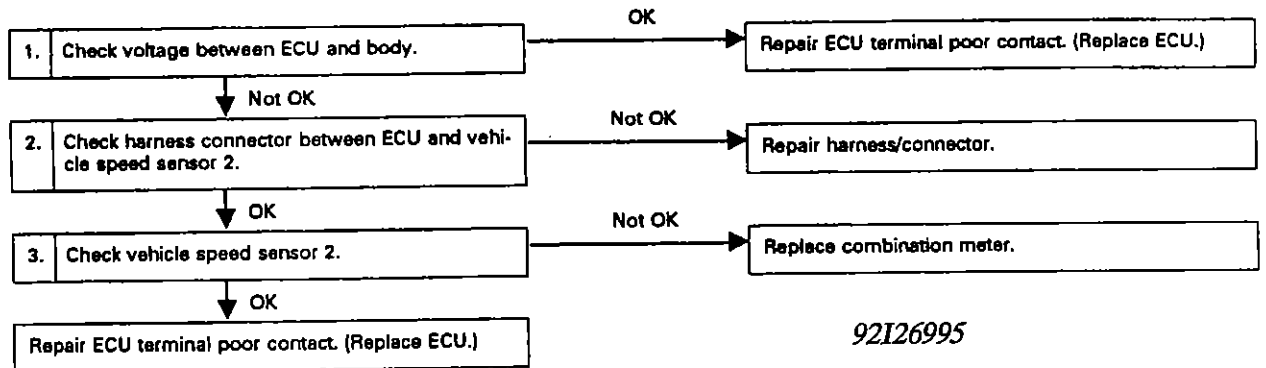

Fig. 28: Flow Chart - Code 33, Vehicle Speed Sensor No. 2

CODE 35, CANISTER PURGE CONTROL (CPC) SOLENOID VALVE

G - TESTS W/CODES

Article Text (p. 20)

1992 Subaru Legacy

For Canadian Tire 777 Niagara Street, Welland Ontario (905) 732-7501 Ext. 325

Copyright © 1997 Mitchell International

Monday, February 22, 1999 01:56PM

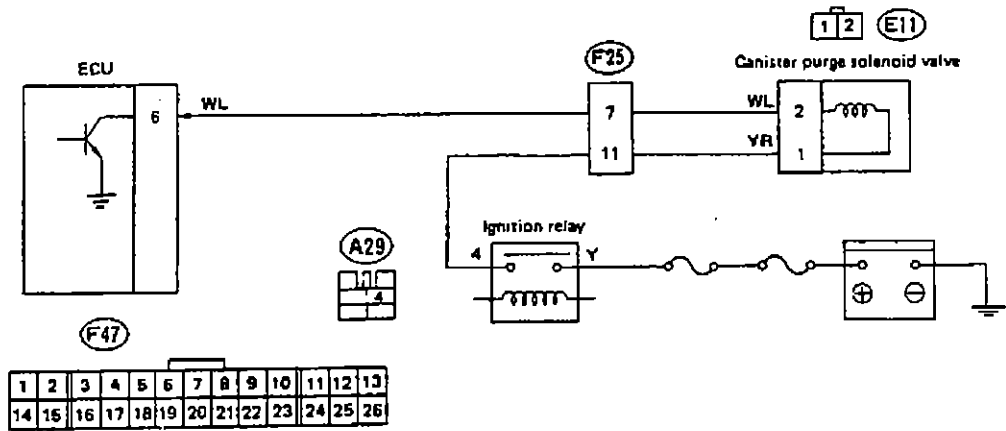

Fig. 29: Schematic - Code 35, Canister Purge Control (CPC) Solenoid

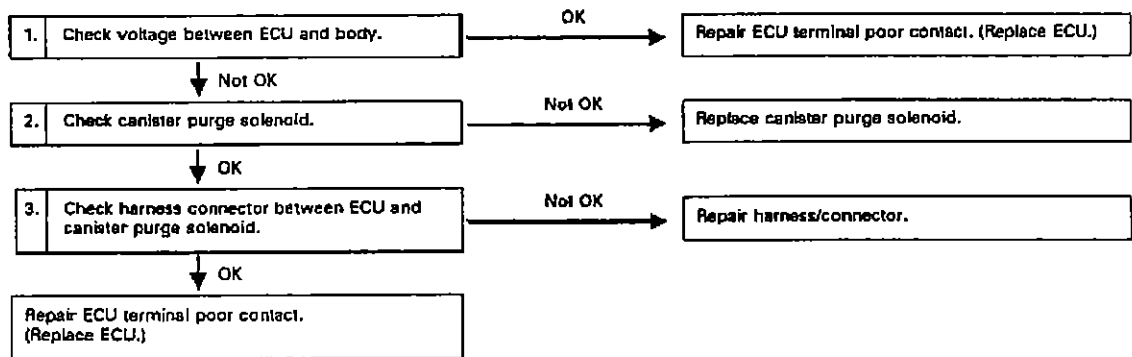

Fig. 30: Flow Chart - Code 35, Canister Purge Control (CPC) Solenoid

CODE 41, AIR/FUEL RATIO CONTROL SYSTEM

G - TESTS W/CODES

Article Text (p. 21)

1992 Subaru Legacy

For Canadian Tire 777 Niagara Street, Welland Ontario (905) 732-7501 Ext. 325

Copyright © 1997 Mitchell International

Monday, February 22, 1999 01:56PM

CONTENT OF DIAGNOSIS:
Faulty learning control system

TROUBLE SYMPTOM:

- Erroneous idling
- Engine stall

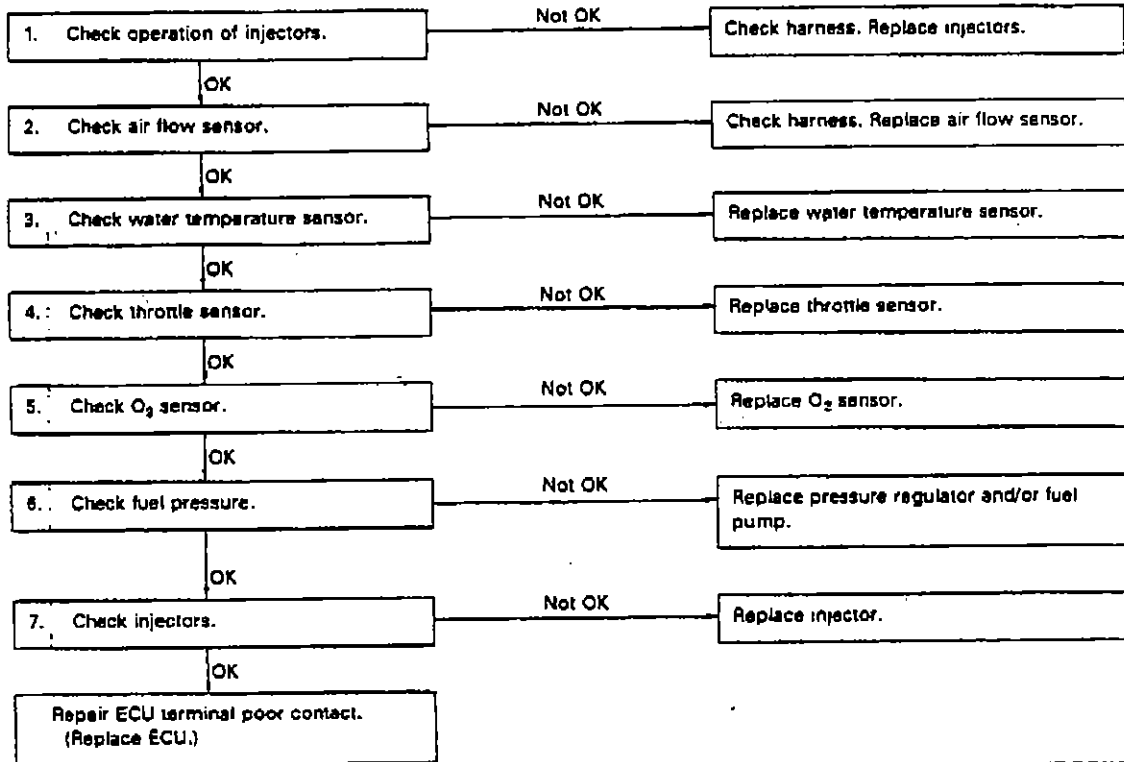

Fig. 31: Flow Chart - Code 41, Air/Fuel Ratio Control System

CODE 42, IDLE SWITCH

G - TESTS W/CODES

Article Text (p. 22)

1992 Subaru Legacy

For Canadian Tire 777 Niagara Street, Welland Ontario (905) 732-7501 Ext. 325

Copyright © 1997 Mitchell International

Monday, February 22, 1999 01:56PM

CONTENT OF DIAGNOSIS:

Abnormal voltage input entered from idle switch

TROUBLE SYMPTOM:

- Erroneous idling
- Engine stall
- Poor driving performance

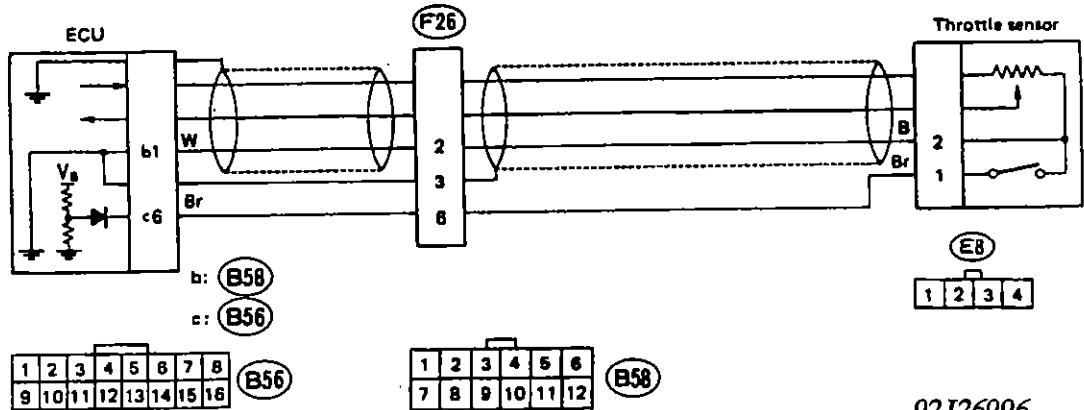
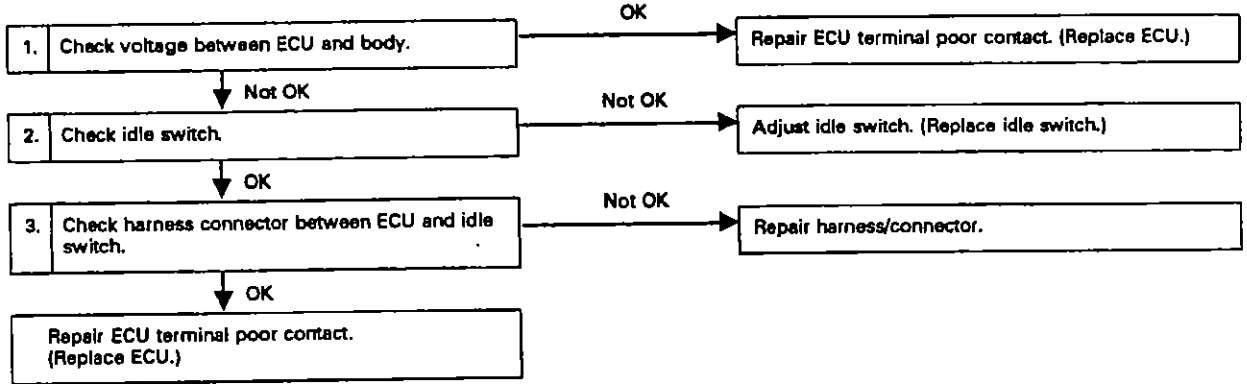

Fig. 32: Schematic - Code 42, Idle Switch

CONTENT OF DIAGNOSIS:

Abnormal voltage input entered from idle switch

TROUBLE SYMPTOM:

- Erroneous idling
- Engine stall
- Poor driving performance

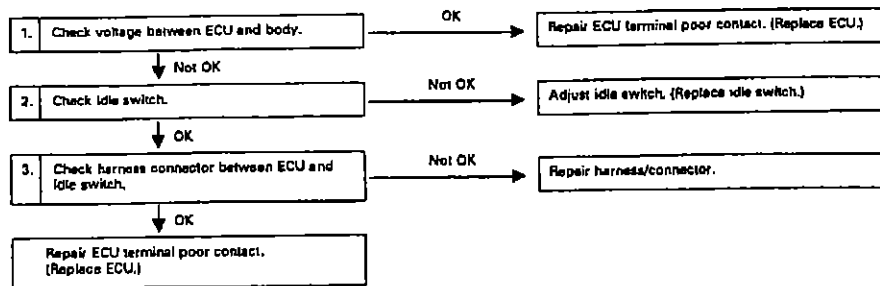

Fig. 33: Flow Chart - Code 42, Idle Switch

CODE 44, WASTEGATE CONTROL DUTY SOLENOID VALVE (TURBO)

G - TESTS W/CODES

Article Text (p. 23)

1992 Subaru Legacy

For Canadian Tire 777 Niagara Street, Welland Ontario (905) 732-7501 Ext. 325

Copyright © 1997 Mitchell International

Monday, February 22, 1999 01:56PM

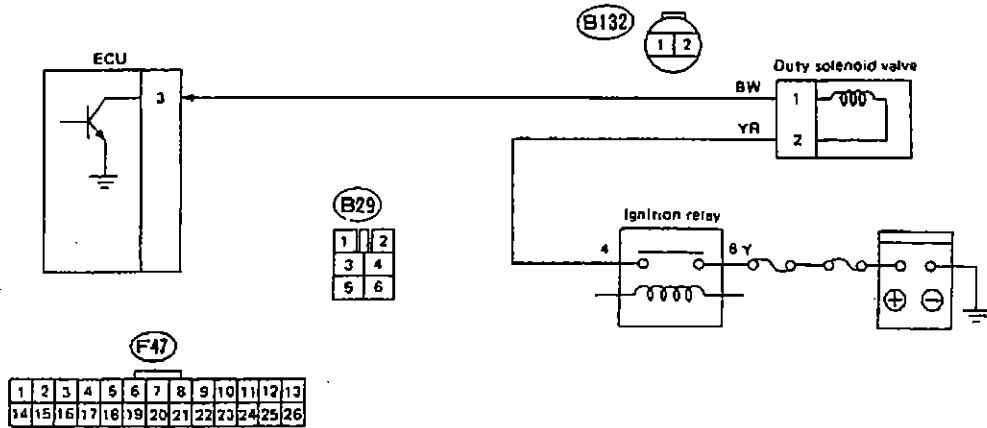

Fig. 34: Schematic - Code 44, Wastegate Control Duty Sol. Valve

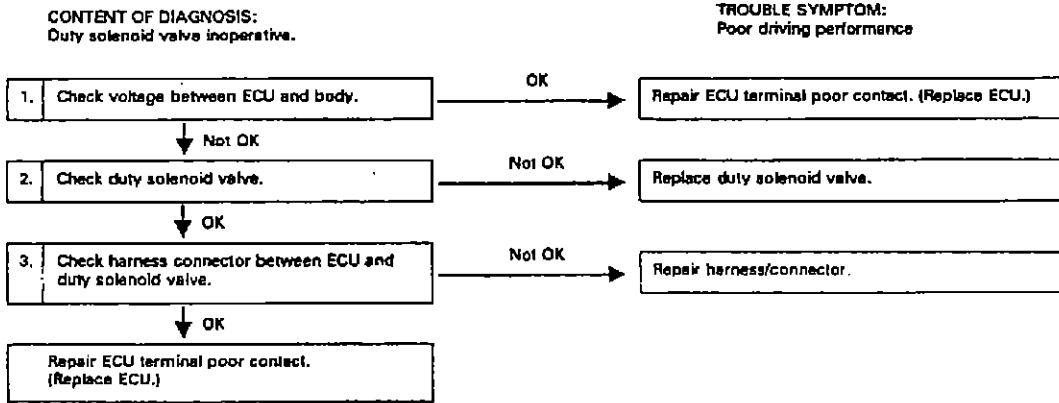

Fig. 35: Flow Chart - Code 44, Wastegate Control Duty Sol. Valve

CODE 45, PRESSURE SENS DUTY SOLENOID (TURBO - WASTEGATE CTRL)

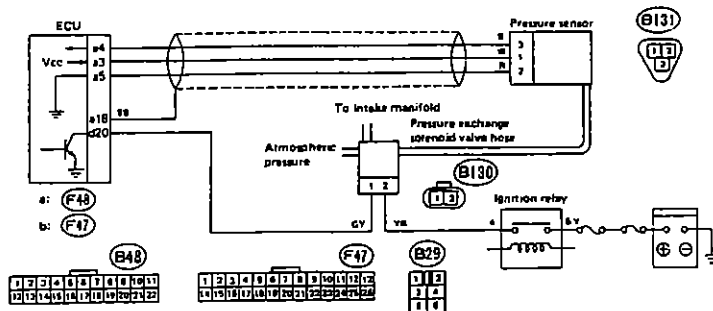

Fig. 36: Schematic - Code 45, Pressure Sensor Duty Solenoid

G - TESTS W/CODES

Article Text (p. 24)

1992 Subaru Legacy

For Canadian Tire 777 Niagara Street, Welland Ontario (905) 732-7501 Ext. 325

Copyright © 1997 Mitchell International

Monday, February 22, 1999 01:56PM

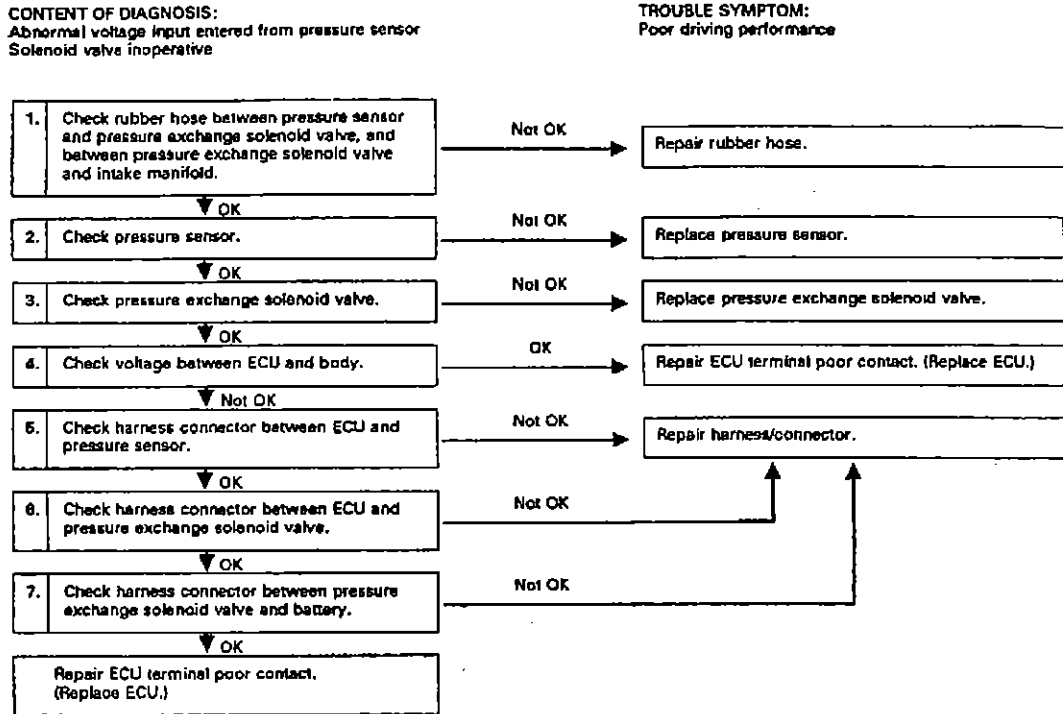

Fig. 37: Flow Chart - Code 45, Pressure Sensor Duty Solenoid

CODE 45, ATMOSPHERIC PRESSURE SENSOR (NON-TURBO)

Code 45 indicates a faulty atmospheric pressure sensor inside the ECU. Symptoms include the following:

- * Rough or erratic idle.
- * Failure of engine to start.

If a code 45 is displayed, replace the ECU.

CODE 49 AIRFLOW SENSOR

Code 49 indicates us of an improper airflow sensor. Symptoms include the following:

- * Rough or erratic idle.
- * Failure of engine to start.

If a code 49 is displayed, check specifications of airflow sensor and ECU. Replace the airflow sensor or ECU with the proper type as follows:

- * Non-turbo models: Hot film type airflow sensor (JECS).
- * Turbo models: Hot wire type airflow sensor (Hitachi).

G - TESTS W/CODES

Article Text (p. 25)

1992 Subaru Legacy

For Canadian Tire 777 Niagara Street, Welland Ontario (905) 732-7501 Ext. 325

Copyright © 1997 Mitchell International

Monday, February 22, 1999 01:56PM

CODE 51, NEUTRAL SAFETY SWITCH (MAN. TRANS.)

CONTENT OF DIAGNOSIS:

Abnormal signal entered from neutral switch

TROUBLE SYMPTOM:

Erroneous idling

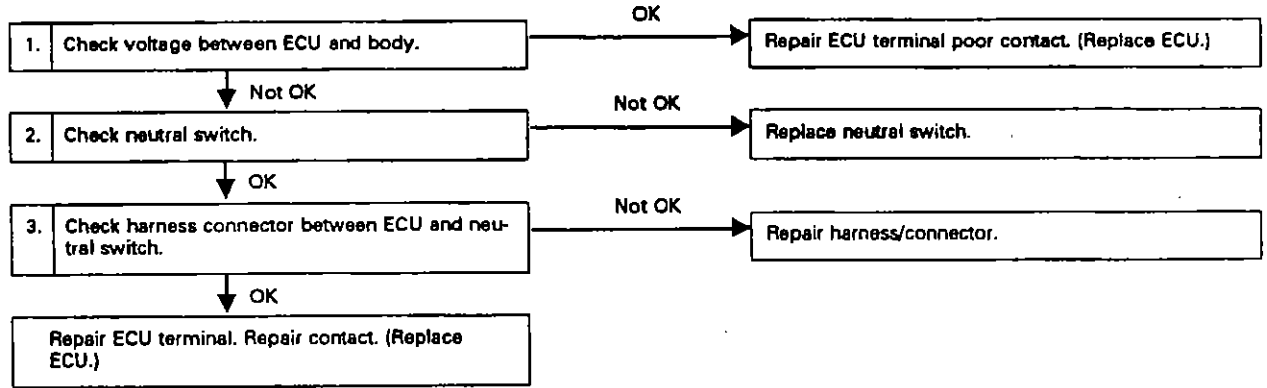

92A26997

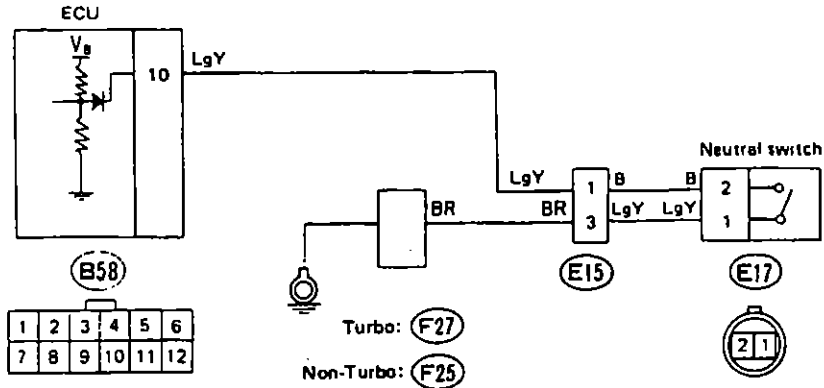

Fig. 38: Schematic - Code 51, Neutral Safety Switch (Man. Trans.)

CONTENT OF DIAGNOSIS:
Abnormal signal entered from neutral switch

TROUBLE SYMPTOM:
Erroneous idling

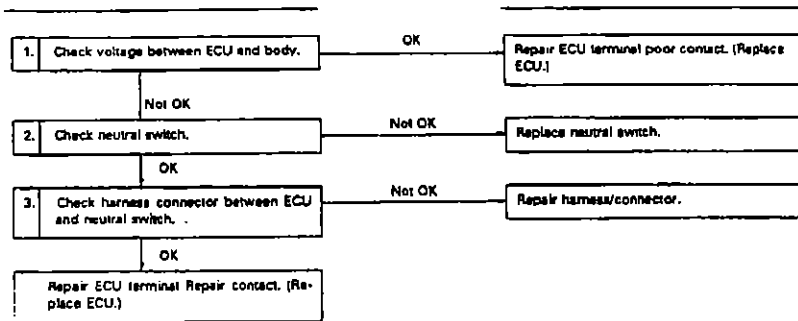

Fig. 39: Flow Chart - Code 51, Neutral Safety Switch (Man. Trans.)

CODE 51, INHIBITOR SWITCH (AUTO. TRANS.)

G - TESTS W/CODES

Article Text (p. 26)

1992 Subaru Legacy

For Canadian Tire 777 Niagara Street, Welland Ontario (905) 732-7501 Ext. 325

Copyright © 1997 Mitchell International

Monday, February 22, 1999 01:56PM

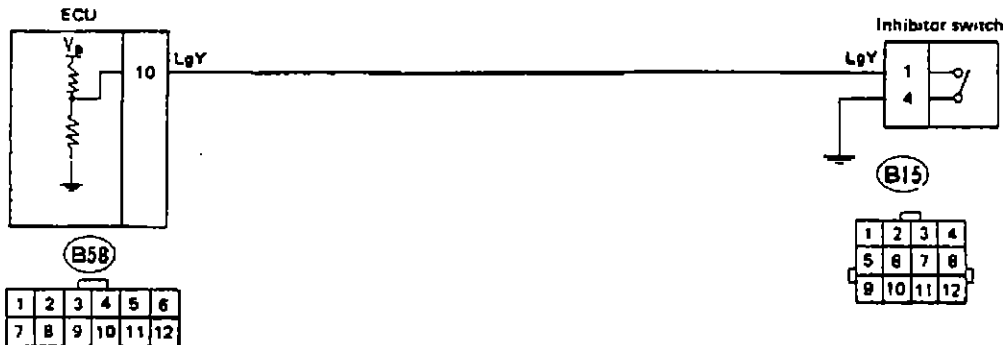

Fig. 40: Schematic - Code 51, Inhibitor Switch (Auto. Trans.)

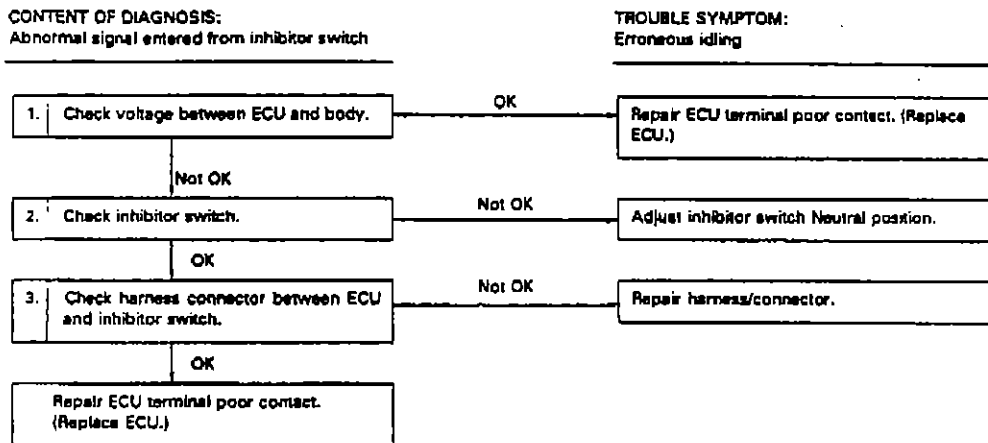

Fig. 41: Flow Chart - Code 51, Inhibitor Switch (Auto. Trans.)

CODE 52, PARKING BRAKE SWITCH (AUTO. TRANS.)

G - TESTS W/CODES

Article Text (p. 27)

1992 Subaru Legacy

For Canadian Tire 777 Niagara Street, Welland Ontario (905) 732-7501 Ext. 325

Copyright © 1997 Mitchell International

Monday, February 22, 1999 01:56PM

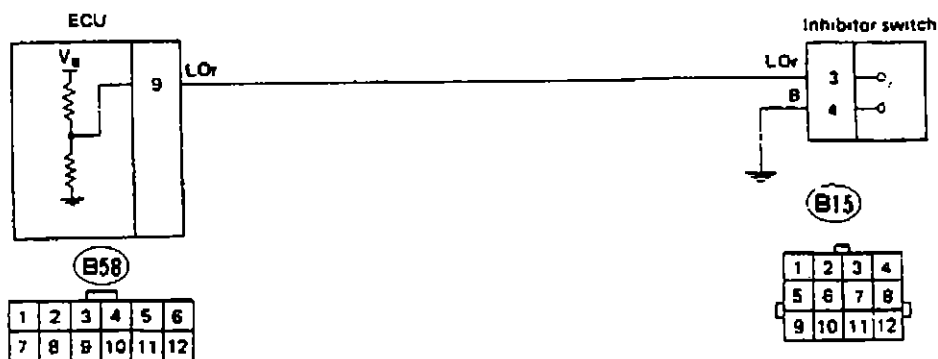

Fig. 42: Schematic - Code 52, Parking Brake Switch (Auto. Trans.)

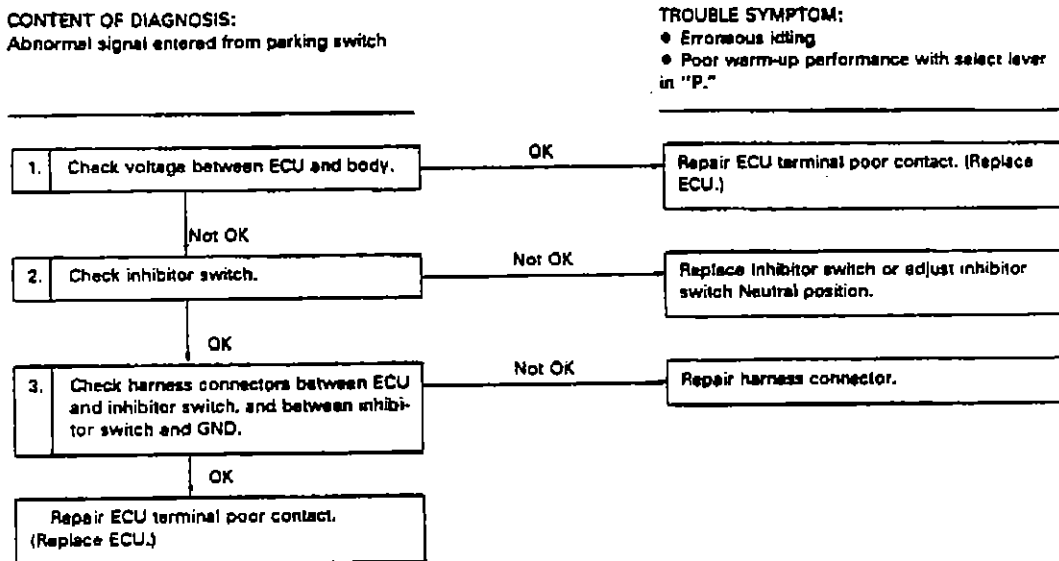

Fig. 43: Flow Chart - Code 52, Parking Brake Switch (Auto. Trans.)

SUMMARY

If no hard fault codes (or only pass codes) are present, driveability symptoms exist or intermittent codes exist, proceed to the H - TESTS W/O CODES article in the ENGINE PERFORMANCE Section for diagnosis by symptom (i.e. ROUGH IDLE, NO START, etc.) or intermittent diagnostic procedures.

H - TESTS W/O CODES

Article Text

1992 Subaru Legacy

For Canadian Tire 777 Niagara Street, Welland Ontario (905) 732-7501 Ext. 325

Copyright © 1997 Mitchell International

Monday, February 22, 1999 02:04PM

ARTICLE BEGINNING

1992 ENGINE PERFORMANCE
Trouble Shooting - No Codes

Justy, Legacy, Loyale, SVX

INTRODUCTION

Before diagnosing symptoms or intermittent faults, perform steps in F - BASIC TESTING and G - TESTS W/ CODES article in the ENGINE PERFORMANCE Section. Use this section to diagnose driveability problems that exist when a hard fault code is not present.

NOTE: Some driveability problems may have been corrected by manufacturer with a revised computer calibration chip or computer control unit. Check with manufacturer for latest chip or computer application.

Symptom checks are intended to direct the technician to malfunctioning component(s) so that further diagnosis may be performed. A "symptom" should lead to further testing of specific components or systems, or verification of adjustment specifications.

Use intermittent test procedures to locate driveability problems that DO NOT occur when the vehicle is being tested. These test procedures should also be used if a soft (intermittent) trouble code was present, but no problem was found during self-diagnostic testing.

NOTE: For specific testing procedures, see I - SYS/COMP TESTS article in the ENGINE PERFORMANCE Section. For verifying specifications, C - SPECIFICATIONS or D - ADJUSTMENTS article in the ENGINE PERFORMANCE Section.

SYMPTOMS

NOTE: For Justy carbureted, see SYMPTOM DIAGNOSIS (JUSTY CARBURETED). For other models, see appropriate SYMPTOM DIAGNOSIS chart.

SYMPTOM DIAGNOSIS (CARBURETED - JUSTY)

Symptom checks cannot be used properly unless the problem occurs while the vehicle is being tested. To reduce diagnostic time, the steps in F - BASIC TESTING and G - TESTS W/ CODES articles in the ENGINE PERFORMANCE Section have been performed before diagnosing a symptom. Symptoms available for diagnosis include:

- * Does not start - cold
- * Does not start - warm

H - TESTS W/O CODES

Article Text (p. 2)

1992 Subaru Legacy

For Canadian Tire 777 Niagara Street, Welland Ontario (905) 732-7501 Ext. 325

Copyright © 1997 Mitchell International

Monday, February 22, 1999 02:04PM

- * Rough or unstable idle
- * Idle speed too high
- * Engine stalls

- * Improper engine operation/poor fuel mileage
- * Engine afterburn occurs
- * Engine backfires
- * Engine knocks

DOES NOT START - COLD

- * Check battery condition.
- * Ensure sufficient secondary spark is available.
- * Ensure ignition and valve timing are correct.
- * Verify choke valve is closed.
- * Ensure fuel level is at specified mark on carburetor sight glass.

- * Ensure fuel system pressure is correct.
- * Check for contaminated fuel.
- * Ensure correct vacuum hose routing.
- * Check slow fuel-cut solenoid valve operation. A click should be heard from solenoid valve as ignition switch is cycled on and off.

- * Check charcoal canister operation by clamping hose(s) shut. If problem discontinues, check vacuum hose routing.
- * Ensure exhaust system is not restricted.

DOES NOT START - WARM

- * Check battery condition.
- * Ensure sufficient secondary spark is available.
- * Ensure ignition and valve timing are correct.
- * Verify choke valve is open.
- * Ensure fuel level is at specified mark on carburetor sight glass.

- * Ensure fuel system pressure is correct.
- * Check for contaminated fuel.
- * Check for clogged fuel return hose.
- * Check for loose or clogged carburetor jets.
- * Check for fuel percolation.

- * Ensure correct vacuum hose routing.
- * Check float chamber vent solenoid operation.
- * Check slow fuel-cut solenoid valve operation. A click should be heard from solenoid valve as ignition switch is cycled on and off.

- * Check charcoal canister operation by clamping hose(s) shut. If problem stops, check vacuum hose routing.

H - TESTS W/O CODES

Article Text (p. 3)

1992 Subaru Legacy

For Canadian Tire 777 Niagara Street, Welland Ontario (905) 732-7501 Ext. 325

Copyright © 1997 Mitchell International

Monday, February 22, 1999 02:04PM

- * Ensure exhaust system is not restricted.

ROUGH OR UNSTABLE IDLE

- * Ensure there are no vacuum leaks.
- * Verify vacuum hose routing is correct.
- * Ensure idle adjustment is correct.
- * Ensure fast idle adjustment is correct.

- * Check vacuum choke break diaphragm.
- * Check choke valve operation.
- * Ensure fuel level is at specified mark on carburetor sight glass.

- * Check for fuel percolation.
- * Check PCV system operation.
- * Check EGR operation.

- * Verify ignition timing is correct.
- * Briefly remove spark plug wires individually to determine if problem can be isolated.
- * Check thermostatic air cleaner operation.

IDLE SPEED TOO HIGH

- * Check idle-up actuator vacuum hose routing.
- * Check fast idle cam for binding.

- * Check linkage for binding.
- * Check choke adjustment and operation.

- * Check throttle cable adjustment.
- * Check ignition timing.

ENGINE STALLS

- * Verify correct air cleaner intake control door operation.
- * Ensure correct choke adjustment and operation.

- * Check idle compensator operation.
- * Check idle mixture adjustment.

- * Ensure there are no vacuum leaks.
- * Check PCV system operation.
- * Check EGR valve operation.

POOR FUEL MILEAGE

- * Ensure there are no vacuum leaks.
- * Ensure ignition and valve timing are correct.
- * Verify choke valve is open (engine warm).
- * Ensure fuel level is at specified mark on carburetor sight

H - TESTS W/O CODES

Article Text (p. 4)

1992 Subaru Legacy

For Canadian Tire 777 Niagara Street, Welland Ontario (905) 732-7501 Ext. 325

Copyright © 1997 Mitchell International

Monday, February 22, 1999 02:04PM

glass.

- * Verify base timing is correct and timing advance system is functional.
- * Ensure sufficient secondary spark is available.
- * Check canister purge control valve operation.

- * Ensure engine has sufficient compression.
- * Ensure exhaust system is not plugged.
- * Check carburetor mixture control duty cycle using dwell meter.
- * Check engine for overheating or overcooling.

ENGINE AFTERBURN OCCURS

- * Ensure idle adjustment is correct.
- * Ensure automatic choke operation is correct.
- * Check for clogged carburetor main air bleed.

- * Ensure ignition timing is correct.
- * Check spark plug cables for poor contact.

ENGINE BACKFIRES

- * Ensure idle adjustment is correct.
- * Ensure automatic choke operation is correct.
- * Check for clogged carburetor main jet.

- * Ensure ignition timing is correct.
- * Check carburetor mixture control duty cycle using dwell meter.

ENGINE KNOCKS

- * Check for clogged carburetor main jet.
- * Ensure operation of ignition control unit is correct.
- * Check EGR valve operation.

- * Ensure ignition timing is correct.
- * Check for poor or contaminated fuel.

- * Check for carbon in combustion chamber.
- * Check engine for overheating.

SYMPTOM DIAGNOSIS (JUSTY PFI)

H - TESTS W/O CODES

Article Text (p. 5)

1992 Subaru Legacy

For Canadian Tire 777 Niagara Street, Welland Ontario (905) 732-7501 Ext. 325

Copyright © 1997 Mitchell International

Monday, February 22, 1999 02:04PM

TROUBLE No.										CHECK ENGINE light		POSSIBLE CAUSE
1	2	3	4	5	6	7	8	9	10	U	D	
	○	○	○	○	○		○	○		ON	*1	FUEL INJECTOR <ul style="list-style-type: none"> Connector not connected Poor contact of terminal Short circuit Discontinuity of wiring harness Performance characteristics unusual Clogged filter Clogged nozzle Stuck open Slight leakage from seat
	○	○	○	○	○		○	○		ON	ON	
	○	○	○	○	○		○	○		ON	ON	
	○	○	○	○	○		○	○		ON	ON	
	△	○	○	△	○		○	△	○	*2	*2	
	△	○	○	△	○		○	△	○	*2	*2	
	△	○	○	○	○		○	△		OFF	*	
			○				○		○	OFF	*	
○										OFF	*	
○										OFF	*	
○										OFF	*	
○										OFF	*	
	○									ON	ON	CRANK ANGLE SENSOR <ul style="list-style-type: none"> Connector disconnected Poor contact of terminal Short circuit Discontinuity of wiring harness
	○									ON	*1	
	○									ON	ON	
	○									ON	ON	
										OFF	*	POWER TRANSISTOR OF IGNITION COIL <ul style="list-style-type: none"> Connector not connected Poor contact of terminal Short circuit Discontinuity of wiring harness
										OFF	*	
										OFF	*	
										OFF	*	
										OFF	*	AIR REGULATOR (1800 cc model only) <ul style="list-style-type: none"> Connector not connected Short circuit Discontinuity of wiring harness
										OFF	*	
										OFF	*	
										ON	ON	KNOCK SENSOR (2700 cc model only) <ul style="list-style-type: none"> Connector not connected Short circuit Discontinuity of wiring harness
										ON	ON	
										ON	ON	
										OFF	*	DUTY SOLENOID <ul style="list-style-type: none"> Connector disconnected Poor contact of terminal Short circuit Discontinuity of wiring harness Disconnected or cracked hose
										OFF	*	
										OFF	*	
										OFF	*	
										ON	ON	AIR CONTROL VALVE (2700 cc model only) <ul style="list-style-type: none"> Connector not connected Poor contact of terminal Short circuit Discontinuity of wiring harness IAS improperly adjusted Stuck open Stuck closed
										ON	*1	
										ON	ON	
										ON	ON	
										OFF	*	
										ON	*	
										OFF	*	
										ON		ENGINE GROUNDING <ul style="list-style-type: none"> Disconnecting of engine grounding terminal at intake manifold Poor contact of engine grounding terminal Discontinuity of wiring harness for engine grounding
										ON	*1	
										ON		
1	2	3	4	5	6	7	8	9	10	11	U	D

#: CHECK ENGINE light

Fig. 1: Chart 1 of 2 - Symptom Diagnosis (Justy PFI Models)
 Courtesy of Subaru of America, Inc.

H - TESTS W/O CODES

Article Text (p. 7)

1992 Subaru Legacy

For Canadian Tire 777 Niagara Street, Welland Ontario (905) 732-7501 Ext. 325

Copyright © 1997 Mitchell International

Monday, February 22, 1999 02:04PM

SYMPTOM DIAGNOSIS (LOYALE)

- *: The CHECK ENGINE light blinks.
- *1: The CHECK ENGINE light blinks when contact is resumed during inspection (although poor contact is present in the D-check).
- *2: The CHECK ENGINE light lights when abnormality is detected in the D-check mode if the idle switch persistently remains off with the accelerator pedal released.
- *3: The CHECK ENGINE light lights when the specified performance characteristics are unusual with the throttle valve in the slightly-opened position.

Symbols shown in the table refer to the degree of possibility of the reason for the trouble ("Very often" to "Rarely").

◎ : Very often

○ : Sometimes

△ : Rarely

☆ : Occurs only in extremely low temperatures

TROUBLE No.											CHECK ENGINE light		POSSIBLE CAUSE
1	2	3	4	5	6	7	8	8	10	11	U	D	
			☆	◎			△	△	○		ON	ON	AIR FLOW METER <ul style="list-style-type: none"> ● Connector not connected ● Poor contact of terminal ● Short circuit ● Discontinuity of wiring harness ● Performance characteristics unusual
			△	◎	◎		◎	○	△		ON	*1	
			☆	◎			△	△	○		ON	ON	
			○	○	○		△	◎	○		OFF	*	
	☆	○	☆		○		○	○	○		ON	ON	COOLANT THERMOSENSOR <ul style="list-style-type: none"> ● Connector not connected ● Poor contact of terminal ● Short circuit ● Discontinuity of wiring harness ● Performance characteristics unusual
	△	△	◎	○	○	△	◎	◎	○		ON	*1	
	☆	○	☆		○		○	○	○		ON	ON	
	☆	○	○	△	○	○	◎	◎	◎		OFF	*	
			◎	○	◎	◎	◎				ON	ON	IDLE SWITCH OF THROTTLE SENSOR <ul style="list-style-type: none"> ● Connector not connected ● Poor contact of terminal ● Short circuit ● Discontinuity of wiring harness ● Improper adjustment
			◎	○	◎	◎	◎				ON	*1	
			◎	◎	△	◎	◎				ON	ON	
			◎		△	◎	◎				ON	ON	
1	2	3	4	5	6	7	8	9	10	11	U	D	

Fig. 3: Chart 1 of 2 - Symptom Diagnosis (Loyale)
 Courtesy of Subaru of America, Inc.

H - TESTS W/O CODES

Article Text (p. 8)

1992 Subaru Legacy

For Canadian Tire 777 Niagara Street, Welland Ontario (905) 732-7501 Ext. 325

Copyright © 1997 Mitchell International

Monday, February 22, 1999 02:04PM

TROUBLE No.											CHECK ENGINE Light		POSSIBLE CAUSE
1	2	3	4	5	6	7	8	9	10	11	U	D	
Δ			⊙	⊙	⊙		⊙			⊙	ON	*1	THROTTLE SENSOR <ul style="list-style-type: none"> Poor contact of terminal Short circuit Discontinuity of wiring harness Performance characteristics unusual
	○	○	Δ	○	⊙		⊙			⊙	ON	ON	
			Δ	○	⊙		⊙			⊙	ON	ON	
			Δ	○	⊙		⊙			⊙	OFF	*3	
○	Δ	○	⊙	⊙	○		○	Δ	⊙		OFF	*	PRESSURE REGULATOR <ul style="list-style-type: none"> Sensing hose cracked or disconnected Fuel pressure too high Fuel pressure too low
	○	○	⊙	⊙	○		○				OFF	*	
			⊙	⊙	○		○				OFF	*	
○	○	○	⊙	⊙	⊙		○				ON	ON	FUEL INJECTOR <ul style="list-style-type: none"> Connector not connected Poor contact of terminal Short circuit Discontinuity of wiring harness Performance characteristics unusual Clogged filter Stuck open Slight leakage from seat
○	○	○	⊙	⊙	⊙		○				ON	*1	
○	○	○	⊙	⊙	⊙		○				ON	ON	
○	○	○	⊙	⊙	⊙		○		⊙		ON	ON	
○	Δ	○	○	○	○		○		○		OFF	*	
			○	○	○		○		○		OFF	*	
	○	Δ	⊙	⊙							ON	ON	AIR CONTROL VALVE <ul style="list-style-type: none"> Connector not connected Poor contact of terminal Short circuit Discontinuity of wiring harness IAS improperly adjusted Stuck open Stuck closed
	Δ	○	⊙	⊙			○				ON	*1	
	○	Δ	⊙	⊙			○				ON	ON	
	○	○	⊙	⊙		⊙					ON	ON	
	○	○	⊙	⊙		⊙					OFF	*	
	○	○	⊙	⊙		⊙					OFF	*	
⊙	○	○	⊙	⊙	⊙		○	○			ON	ON	CRANK ANGLE SENSOR <ul style="list-style-type: none"> Connector not connected Poor contact of terminal Short circuit Discontinuity of wiring harness
⊙			⊙	⊙	⊙		○	○			ON	*1	
⊙			⊙	⊙	⊙		○	○			ON	ON	
⊙			⊙	⊙	⊙		○	○			ON	ON	
⊙	○	○	⊙	⊙	⊙		○	Δ			OFF	*	POWER TRANSISTOR OF IGNITION COIL <ul style="list-style-type: none"> Connector not connected Poor contact of terminal Short circuit Discontinuity of wiring harness
⊙			⊙	⊙	⊙		○	Δ			OFF	*	
⊙			⊙	⊙	⊙		○	Δ			OFF	*	
⊙			⊙	⊙	⊙		○	Δ			OFF	*	
1	2	3	4	5	6	7	8	9	10	11	U	D	

Fig. 4: Chart 2 of 2 - Symptom Diagnosis (Loyale)
 Courtesy of Subaru of America, Inc.

H - TESTS W/O CODES

Article Text (p. 9)

1992 Subaru Legacy

For Canadian Tire 777 Niagara Street, Welland Ontario (905) 732-7501 Ext. 325

Copyright © 1997 Mitchell International

Monday, February 22, 1999 02:04PM

SYMPTOM DIAGNOSIS (LEGACY)

Parts to check		ECU power supply	Air flow sensor	Water temperature sensor	Idle switch	Throttle sensor	Fuel pump	Pressure regulator	Fuel injector	Igniter (power transistor)	Ignition coil	Spark plug	Knock sensor	Cam angle sensor	Crank angle sensor	Bypass air control solenoid valve	O ₂ sensor	Wastegate control solenoid valve
Symptom	Initial combustion does not occur.	1	10	11			5	8	7	2	3	4		8	9			
	Initial combustion occurs.	1		10			2	3	4	5	6	7		8	9	11		
	Engine stalls after initial combustion.	1	2	7		8	4	5	6	11	12	13		9	10	3		
	Rough idling	1	3	12	6	7	4	6	6	9	10	11		13	14	2	15	16
	Hard to drive at constant speed	1	4	6	8	7	3	2	9	12	13	14		10	11		5	15
	Poor acceleration/ deceleration	1	2	6	7	8	3	4	5	13	14	16	9	11	12	10	10	2
	Poor return to idle			3	2											1		
	Backfire			3	4	5		6	7					2	1			
	Knocking		1	2				4	5					3		6		7
	Excessive fuel consumption		3	4				1	2									
Shocks while driving	1	8						7	4	5	6		2	3				
Poor engine revving		2	3	4	5		1											
Remarks	Include engine ground circuit.															Check hoses.		Check hoses.

92H26978

Fig. 5: Symptom Diagnosis (Legacy)
Courtesy of Subaru of America, Inc.

SYMPTOM DIAGNOSIS (SVX)

Parts to check		ECU power supply	Air flow sensor	Water temperature sensor	Throttle sensor	Fuel pump	Pressure regulator	Fuel injector	Igniter	Ignition coil	Spark plug	Knock sensor 1 & 2	Crank angle sensor 1	Crank angle sensor 2	Cam angle sensor	O ₂ sensor 1 & 2	Induction solenoid valve	Bypass air control solenoid valve	Auxiliary air control valve
Symptom	Initial combustion does not occur.	1	11	12		5	6	7	2	3	4		8	9	10				
	Initial combustion occurs.	1	11			2	3	4	5	6	7		8	9	10			12	13
	Engine stalls after initial combustion.	1	2	8	9	6	8	7	13	14	16		10	11	12			3	4
Rough idling	1	3	11	10	7	8	9	4	5	6		12	13	14	15			2	
Hard to drive at constant speed	1	4	6	7	3	2	5	12	13	14		9	10	11	6				
Poor acceleration/ deceleration	1	2	6	7	3	4	5	13	14	16	8	10	11	12		16	9		
Poor return to idle			3	2														1	
Backfire			4	5		6	7					3	8	7					
Knocking		1	2			4	5												
Excessive fuel consumption		3	4			1	2												
Shocks while driving	1	5				6	5	6	7				2	3	4				
Poor engine revving		2	3	4		1													
Remarks	Include ECU ground circuit.																Check hoses and relating part	Check hoses	Check hoses

92B26980

Fig. 6: Symptom Diagnosis (SVX)
Courtesy of Subaru of America, Inc.

H - TESTS W/O CODES

Article Text (p. 10)

1992 Subaru Legacy

For Canadian Tire 777 Niagara Street, Welland Ontario (905) 732-7501 Ext. 325

Copyright © 1997 Mitchell International

Monday, February 22, 1999 02:05PM

INTERMITTENTS

INTERMITTENT PROBLEM DIAGNOSIS

Intermittent fault testing requires duplicating circuit or component failure to identify problem. These procedures may lead to the computer setting a fault code, which may help in diagnosis.

If problem vehicle does not produce fault codes, monitor voltage or resistance values using a DVOM while attempting to reproduce the conditions causing intermittent fault. A status change on DVOM indicates a fault has been located.

Use a DVOM to pinpoint faults. When monitoring voltage, ensure ignition switch is in ON position or engine is running. Ensure ignition switch is in OFF position or negative battery cable is disconnected when monitoring circuit resistance. Status changes on DVOM during test procedures indicate area of fault.

TEST PROCEDURES

Intermittent Simulation

To reproduce the conditions creating an intermittent fault, use the following methods:

- * Lightly vibrate component.
- * Heat component.
- * Wiggle or bend wiring harness.

- * Spray component with water.
- * Remove/apply vacuum source.

Monitor circuit/component voltage or resistance while simulating intermittent. If engine is running, monitor for self-diagnostic codes. Use test results to identify a faulty component or circuit.

END OF ARTICLE

L - WIRING DIAGRAMS

Fig. 3: Wiring Diagram (Legacy 2.2L PFI & Turbo)

1992 Subaru Legacy

For Canadian Tire 777 Niagara Street, Welland Ontario (905) 732-7501 Ext. 325

Copyright © 1997 Mitchell International

Saturday, February 20, 1999 05:12PM

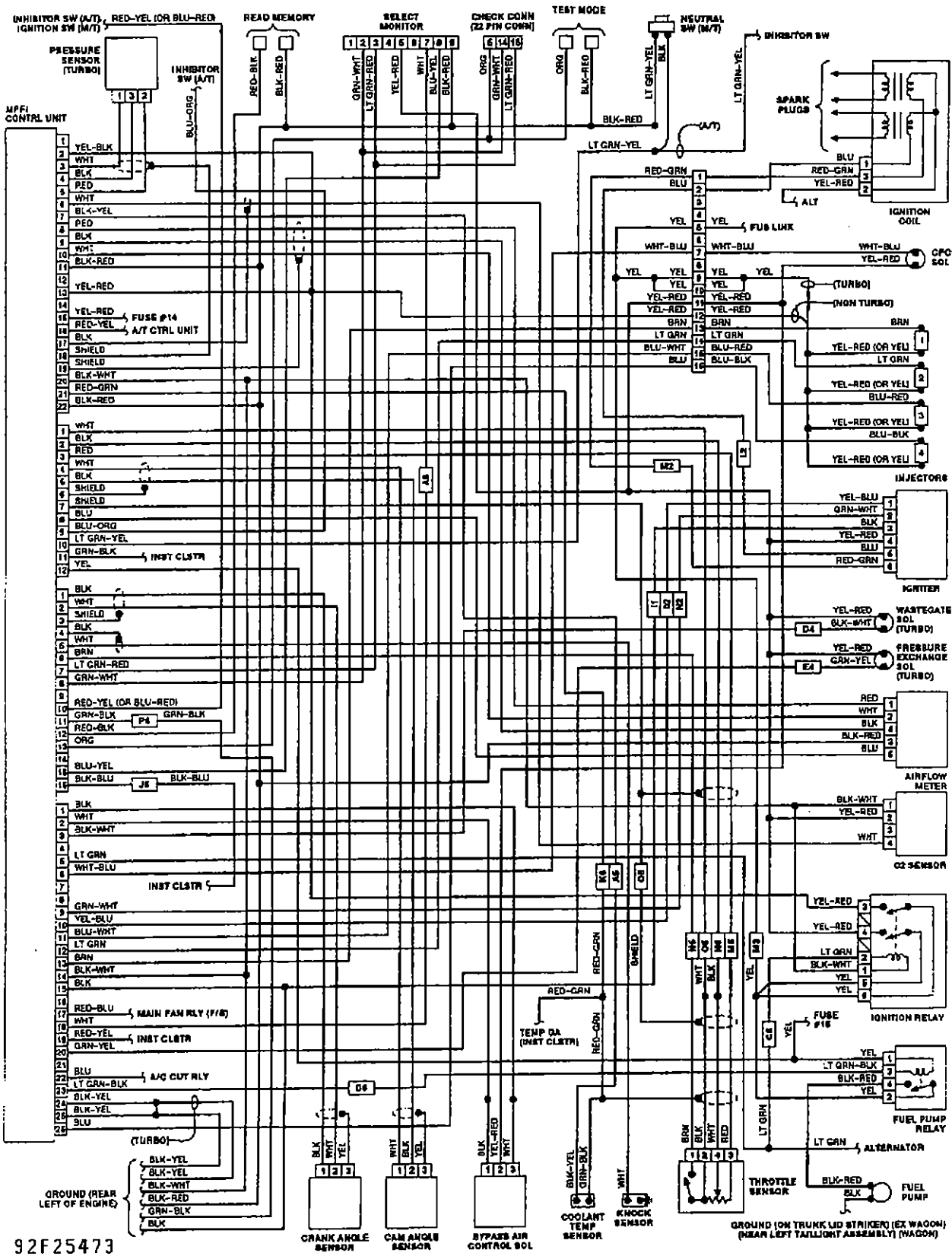

WIRING DIAGRAMS

Article Text

1992 Subaru Legacy

For Canadian Tire 777 Niagara Street, Welland Ontario (905) 732-7501 Ext. 325

Copyright © 1997 Mitchell International

Saturday, February 20, 1999 05:56PM

ARTICLE BEGINNING

1992 WIRING DIAGRAMS

Subaru

Legacy

COMPONENT LOCATION MENU

COMPONENT LOCATION MENU

Component	Figure No. (Location)
A/C-HEATER SYSTEM	10 (B, E 36, 39)
A/T CONTROL SYSTEM	7 (A, E 24, 27)
AIR BAG CONTROL SYSTEM	10 (A, B 38, 39)
ALTERNATOR	1 (D 3)
ANTI-LOCK BRAKE SYSTEM	8 (C, E 28, 31)
AUTOMATIC SHOULDER BELT CONTROL SYSTEM	13 (A, B 48, 51)
BACKUP LIGHT SWITCH (MANUAL TRANSMISSION)	7 (D 27)
BATTERY	1 (A 2)
BRAKE FLUID LEVEL SENSOR	12 (B 47)
CHECK CONNECTOR	3 (A-B 11)
CHECK CONNECTOR (TURBO)	5 (A-B 19)
CIGARETTE LIGHTER	11 (C 42)
CLUTCH SWITCH	1 (B 3)
COOLANT TEMPERATURE SENSOR	2 (E 6)
COOLANT TEMPERATURE SENSOR (TURBO)	4 (E 14)
CRUISE CONTROL SYSTEM	8 (A, B 28, 31)
DIMMER/PASSING SWITCH	11 (D 40)
DIODE	2, 4 (E 7, E 15)
DIRECTIONAL SWITCH	11 (C 40)
DOME LIGHT	12 (C, D 47)
DOOR SWITCHES	12 (B, C 47)
FRONT WIPER/WASHER SYSTEM	11 (A, B 40, 42)
FUEL GAUGE UNITS	14 (E 52, 53)
FUEL INJECTORS	3 (D 8)
FUEL PUMP	2 (E 7)
FUEL PUMP (TURBO)	4 (E 15)
FUEL PUMP RELAY	2 (E 7)
FUEL PUMP RELAY (TURBO)	4 (E 15)
FUSE/RELAY BOX (F/B)	6 (C, E 20, 23)
HAZARD SWITCH	11 (B, C 40)
HEIGHT CONTROL SYSTEM	9 (A, E 32, 35)
HORN SYSTEM	1 (C, D 1)
IGNITION COIL	2 (E 8)
IGNITION COIL (TURBO)	5 (E 16)
IGNITION RELAY	2 (D 7)
IGNITION SWITCH	6 (A 20)
IGNITION RELAY (TURBO)	4 (D 15)
ILLUMINATION LIGHT CONTROL UNIT	11 (D 43)

WIRING DIAGRAMS

Article Text (p. 2)

1992 Subaru Legacy

For Canadian Tire 777 Niagara Street, Welland Ontario (905) 732-7501 Ext. 325

Copyright © 1997 Mitchell International

Saturday, February 20, 1999 05:56PM

INHIBITOR RELAY	8 (A 28)
INHIBITOR SWITCH	7 (C, D 27)
INSTRUMENT PANEL ILLUMINATION LIGHTS	11 (E 40, 43)
INSTRUMENT CLUSTER	12 (A, E 44, 45)
INTERIOR LIGHTS	12 (D, E 47)
KEY WARNING SWITCH	7 (E 26, 27)
LIGHT SWITCH	2 (D 4)
MAIN FAN RELAY	6 (D 20)
MAIN FUSE BLOCK (MAIN F/B)	1 (B, C 2, 3)
MULTI PORT FUEL INJECTOR CONTROL UNIT	2 (A, E 4)
MULTI PORT FUEL INJECTOR CONTROL UNIT (TURBO)	4 (A, E 12)
OIL PRESSURE SWITCH	12 (A 47)
PARKING BRAKE SWITCH	12 (A, B 47)
PARKING LIGHT SWITCH	11 (E 40)
POWER ANTENNA	14 (D 55)
POWER DOOR LOCK SYSTEM	13 (B, D 48, 51)
POWER MIRROR SYSTEM	14 (A 52-54)
POWER WINDOW SYSTEM	13 (D, E 48, 51)
REAR DEFOGGER RELAY	6 (D 20)
REAR DEFOGGER SWITCH	14 (C 52, 53)
REAR WIPER/WASHER SYSTEM	14 (B 52, 54)
SELECT MONITOR	3 (A 11)
SELECT MONITOR (TURBO)	5 (A 19)
SHIFT LOCK CONTROL UNIT	7 (E 27)
SPOT LIGHT	11 (D 43)
STARTER	1 (A 3)
STARTER INTERLOCK RELAY	1 (A 3)
STOP LIGHT SWITCH (WITH CRUISE CONTROL)	8 (B 28)
STOP LIGHT SWITCH (WITHOUT CRUISE CONTROL)	14 (D 53)
SUB FUSE LINKS	1 (D 3)
SUN ROOF SYSTEM	14 (D 52, 53)
TAIL LIGHT ILLUMINATION RELAY	6 (C, D 20)
TEMPERATURE SENSORS	12 (A 47)
TRUNK LIGHT SWITCH	14 (C 52, 53)
VANITY MIRROR LIGHT	11 (C 43)

WIRING DIAGRAMS

WIRING DIAGRAMS

Article Text (p. 3)

1992 Subaru Legacy

For Canadian Tire 777 Niagara Street, Welland Ontario (905) 732-7501 Ext. 325

Copyright © 1997 Mitchell International

Saturday, February 20, 1999 05:56PM

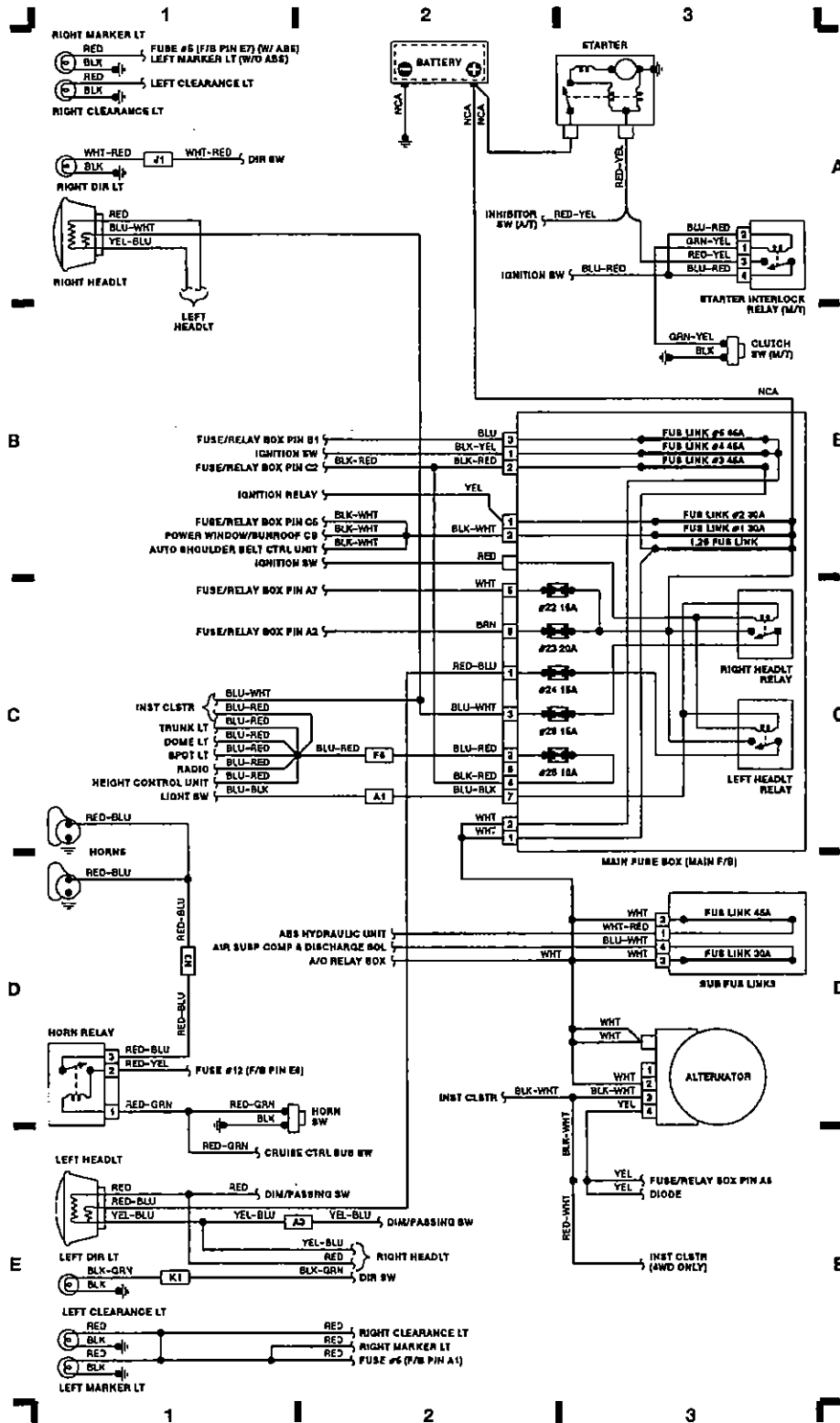

93B03650

Fig. 1: Engine Compartment, Headlights (Grid 1-3)

WIRING DIAGRAMS

Article Text (p. 4)

1992 Subaru Legacy

For Canadian Tire 777 Niagara Street, Welland Ontario (905) 732-7501 Ext. 325

Copyright © 1997 Mitchell International

Saturday, February 20, 1999 05:56PM

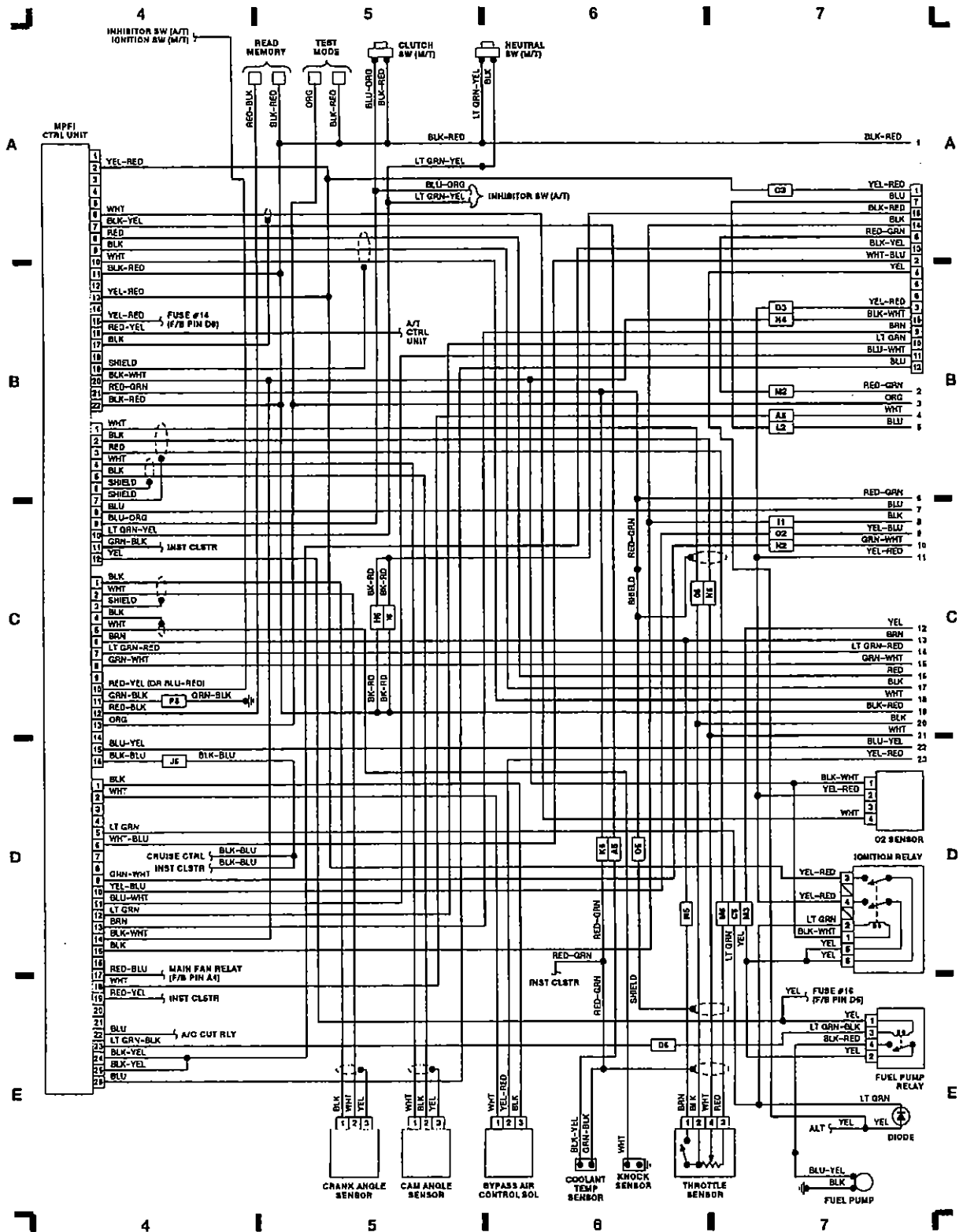

93D03651

Fig. 2: MPFI Control Unit (Non Turbo, Ignition Relay) (Grid 4-7)

WIRING DIAGRAMS

Article Text (p. 5)

1992 Subaru Legacy

For Canadian Tire 777 Niagara Street, Welland Ontario (905) 732-7501 Ext. 325

Copyright © 1997 Mitchell International

Saturday, February 20, 1999 05:56PM

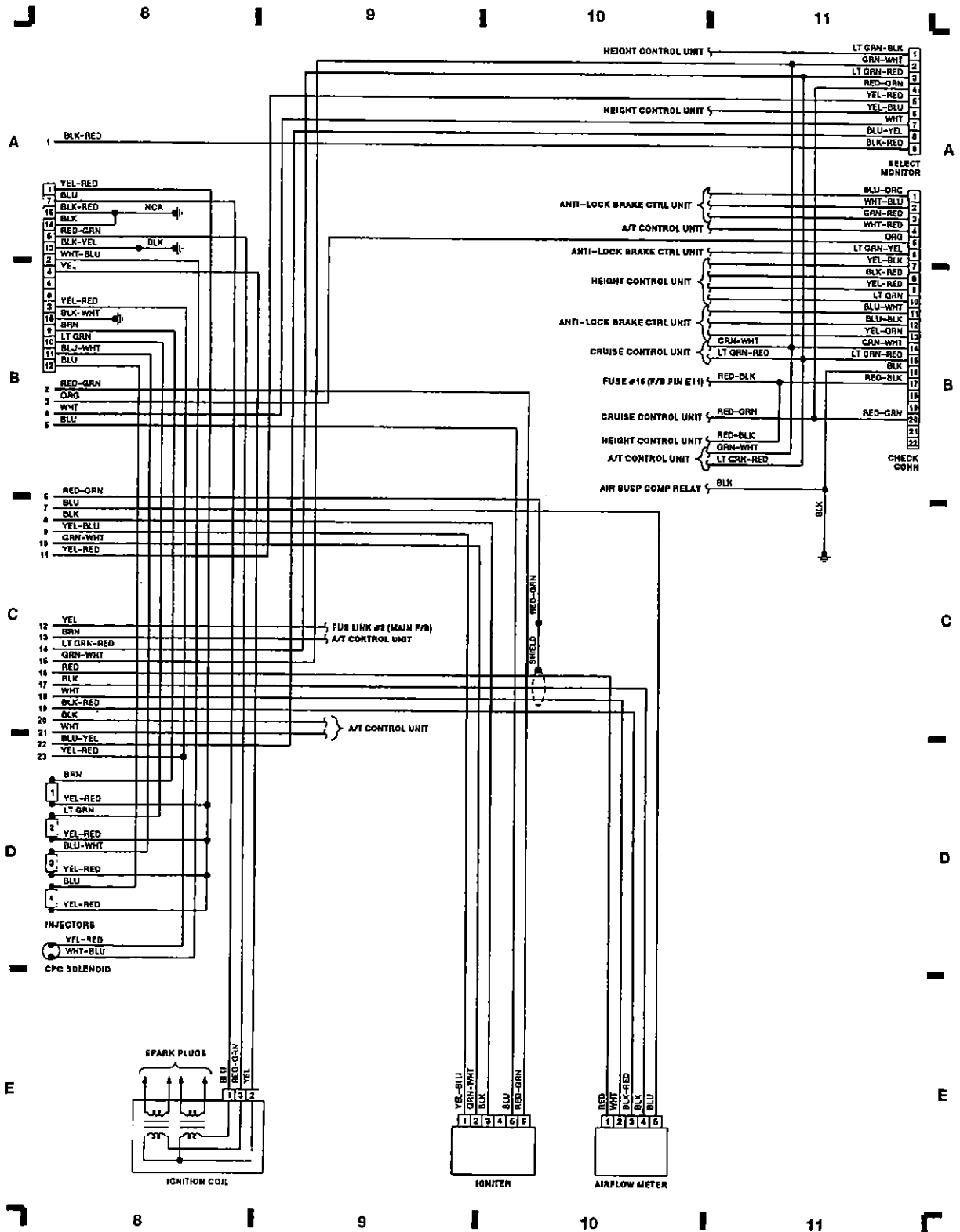

93F03652

Fig. 3: Check Connector, Ignition Coil (Non Turbo) (Grid 8-11)

WIRING DIAGRAMS

Article Text (p. 6)

1992 Subaru Legacy

For Canadian Tire 777 Niagara Street, Welland Ontario (905) 732-7501 Ext. 325

Copyright © 1997 Mitchell International

Saturday, February 20, 1999 05:56PM

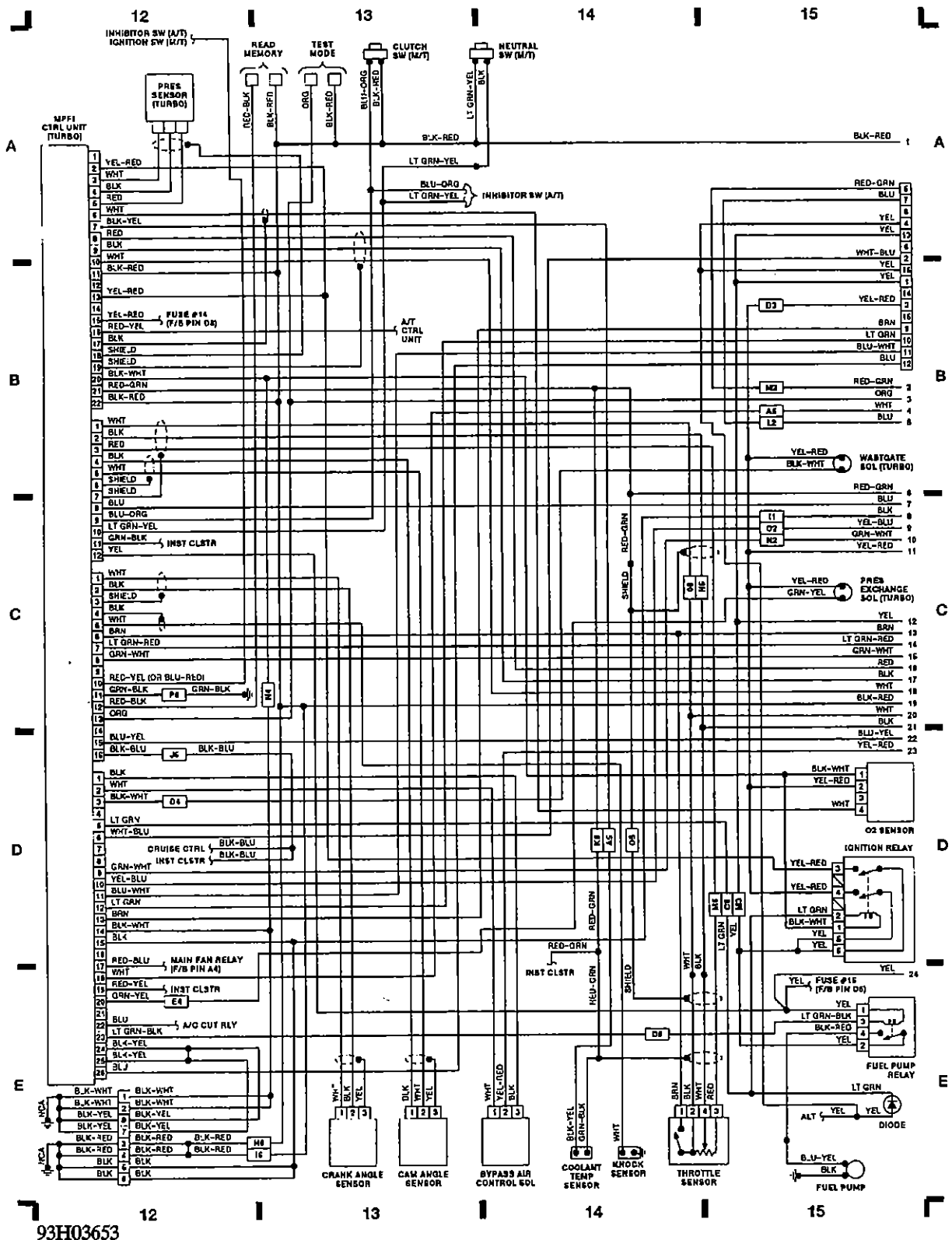

93H03653

Fig. 4: MPFI Control Unit (Turbo) (Grid 12-15)

WIRING DIAGRAMS

Article Text (p. 8)

1992 Subaru Legacy

For Canadian Tire 777 Niagara Street, Welland Ontario (905) 732-7501 Ext. 325

Copyright © 1997 Mitchell International

Saturday, February 20, 1999 05:56PM

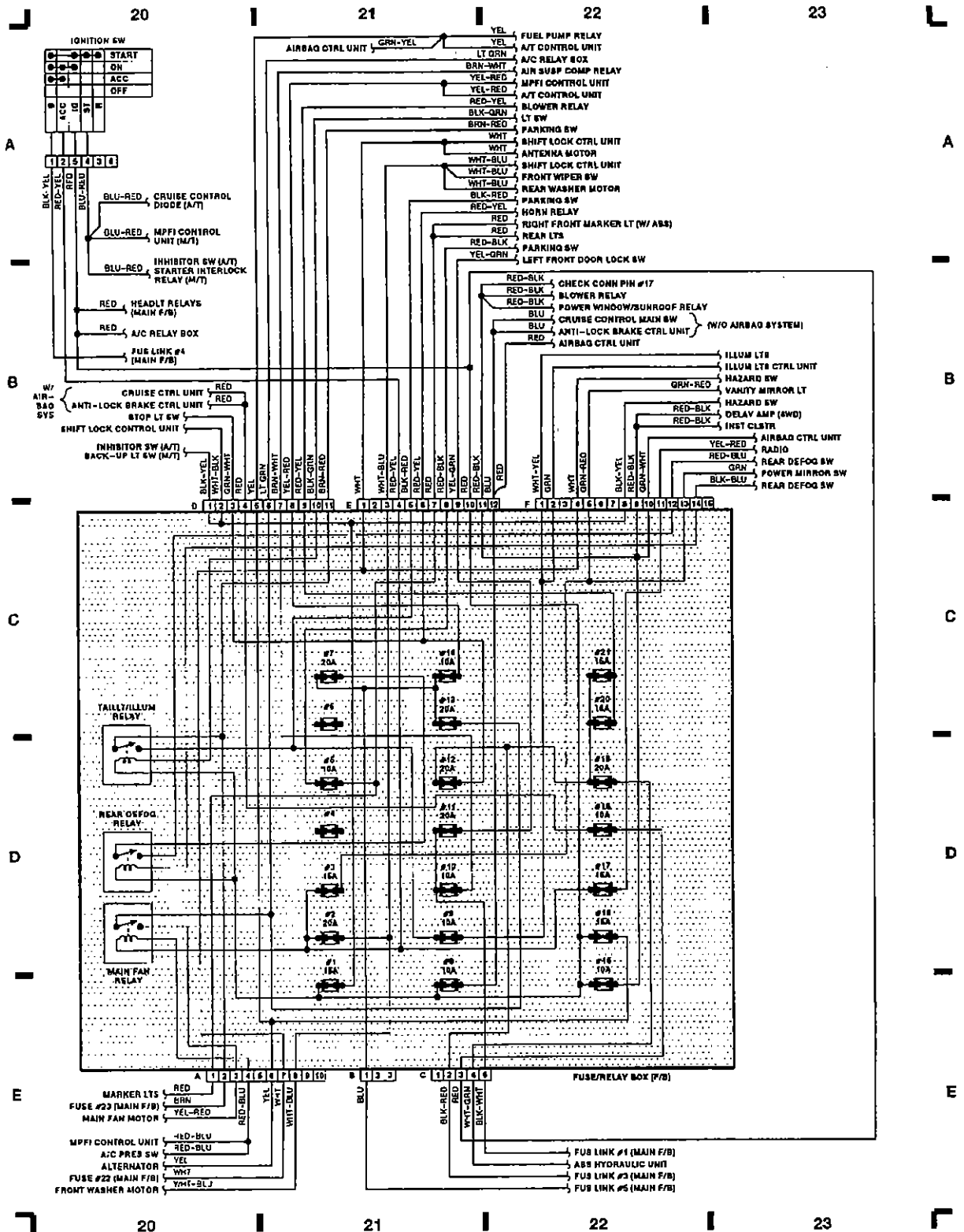

93C03655

Fig. 6: Fuse Relay Box, Ignition Switch (Grid 20-23)

WIRING DIAGRAMS

Article Text (p. 9)

1992 Subaru Legacy

For Canadian Tire 777 Niagara Street, Welland Ontario (905) 732-7501 Ext. 325

Copyright © 1997 Mitchell International

Saturday, February 20, 1999 05:56PM

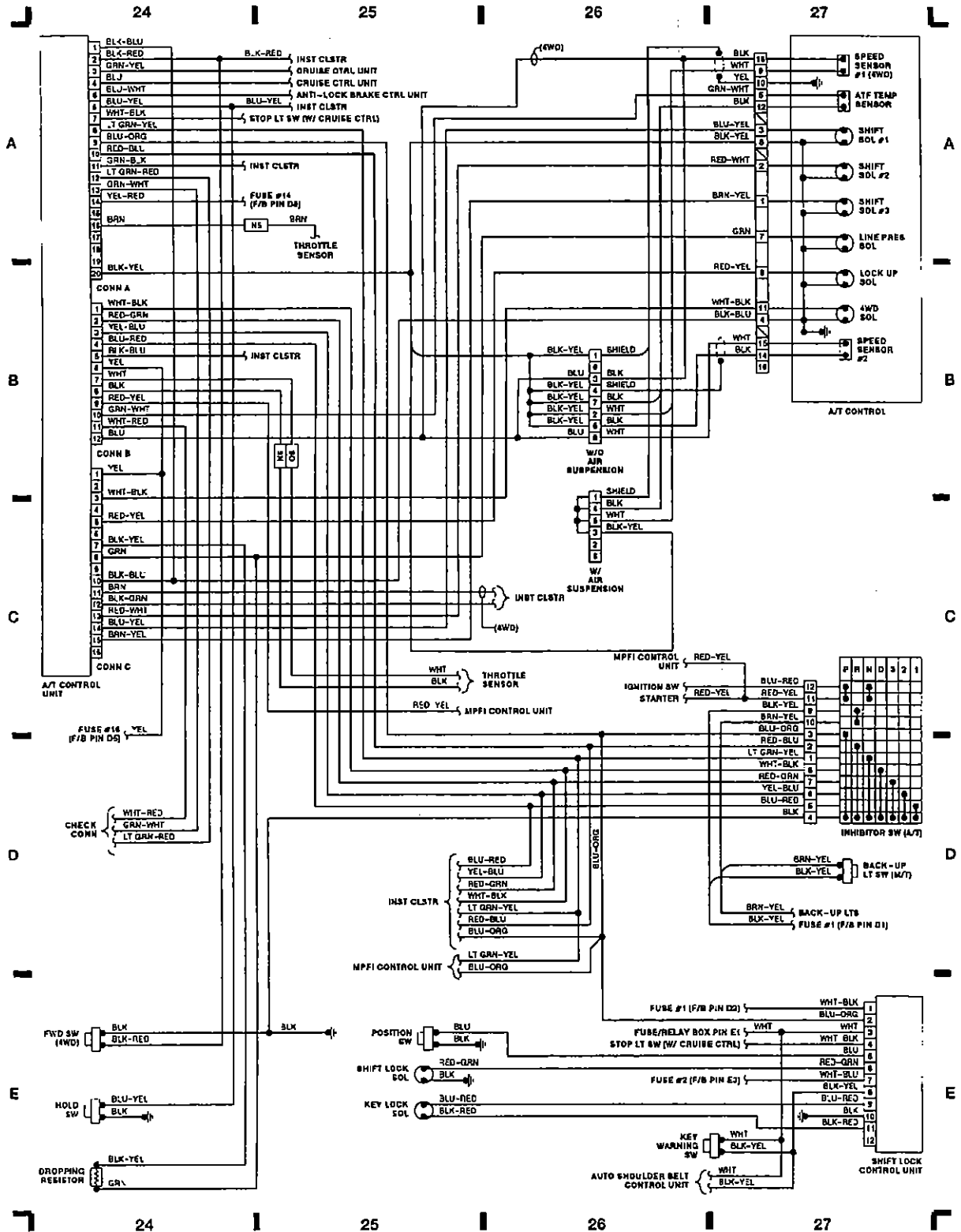

93E03656

Fig. 7: A/T Control Unit, Shift Lock Control Unit (Grid 24-27)

WIRING DIAGRAMS

Article Text (p. 10)

1992 Subaru Legacy

For Canadian Tire 777 Niagara Street, Welland Ontario (905) 732-7501 Ext. 325

Copyright © 1997 Mitchell International

Saturday, February 20, 1999 05:56PM

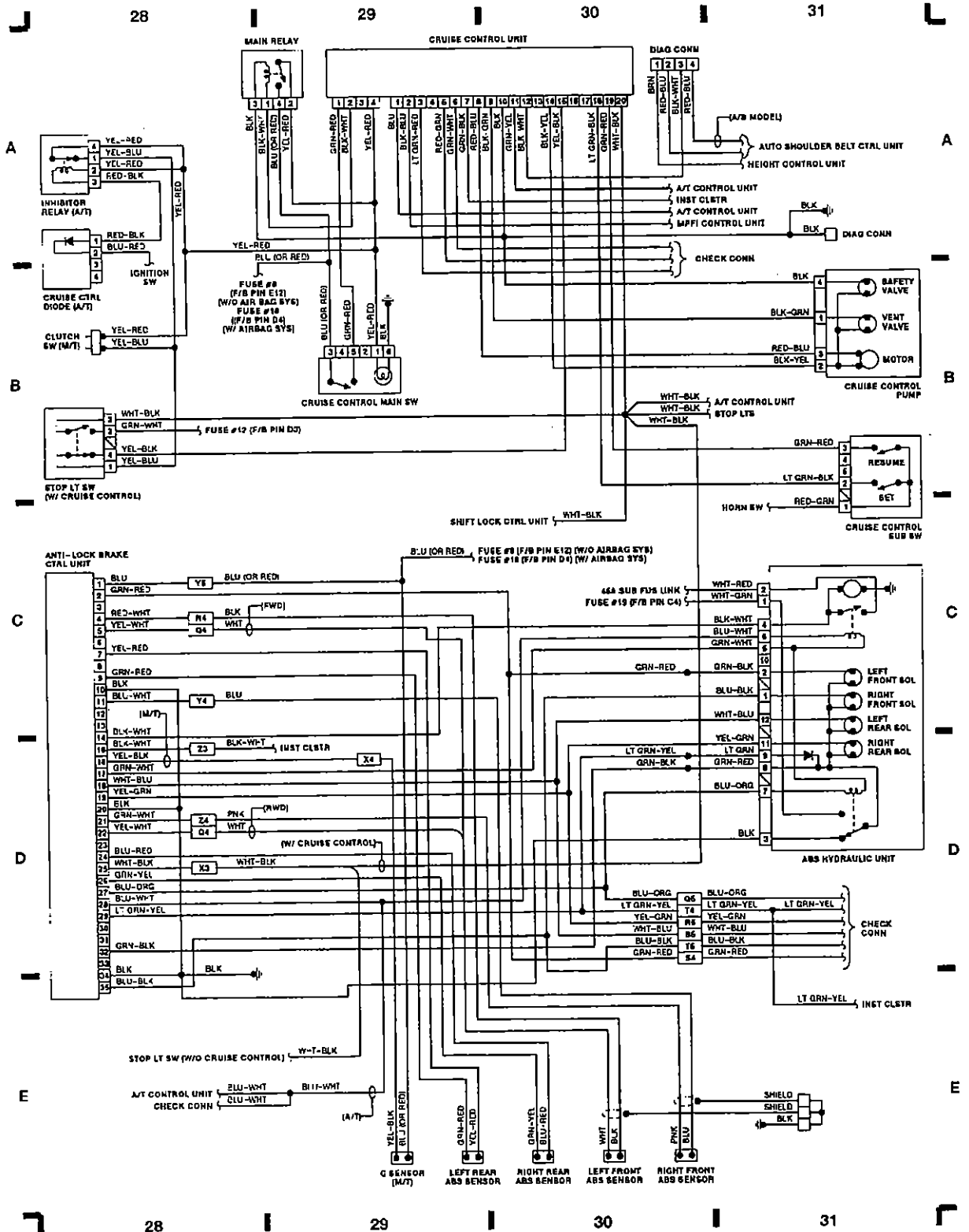

93G03657

Fig. 8: ABS Control Unit, Cruise Control Unit (Grid 28-31)

WIRING DIAGRAMS

Article Text (p. 11)

1992 Subaru Legacy

For Canadian Tire 777 Niagara Street, Welland Ontario (905) 732-7501 Ext. 325

Copyright © 1997 Mitchell International

Saturday, February 20, 1999 05:56PM

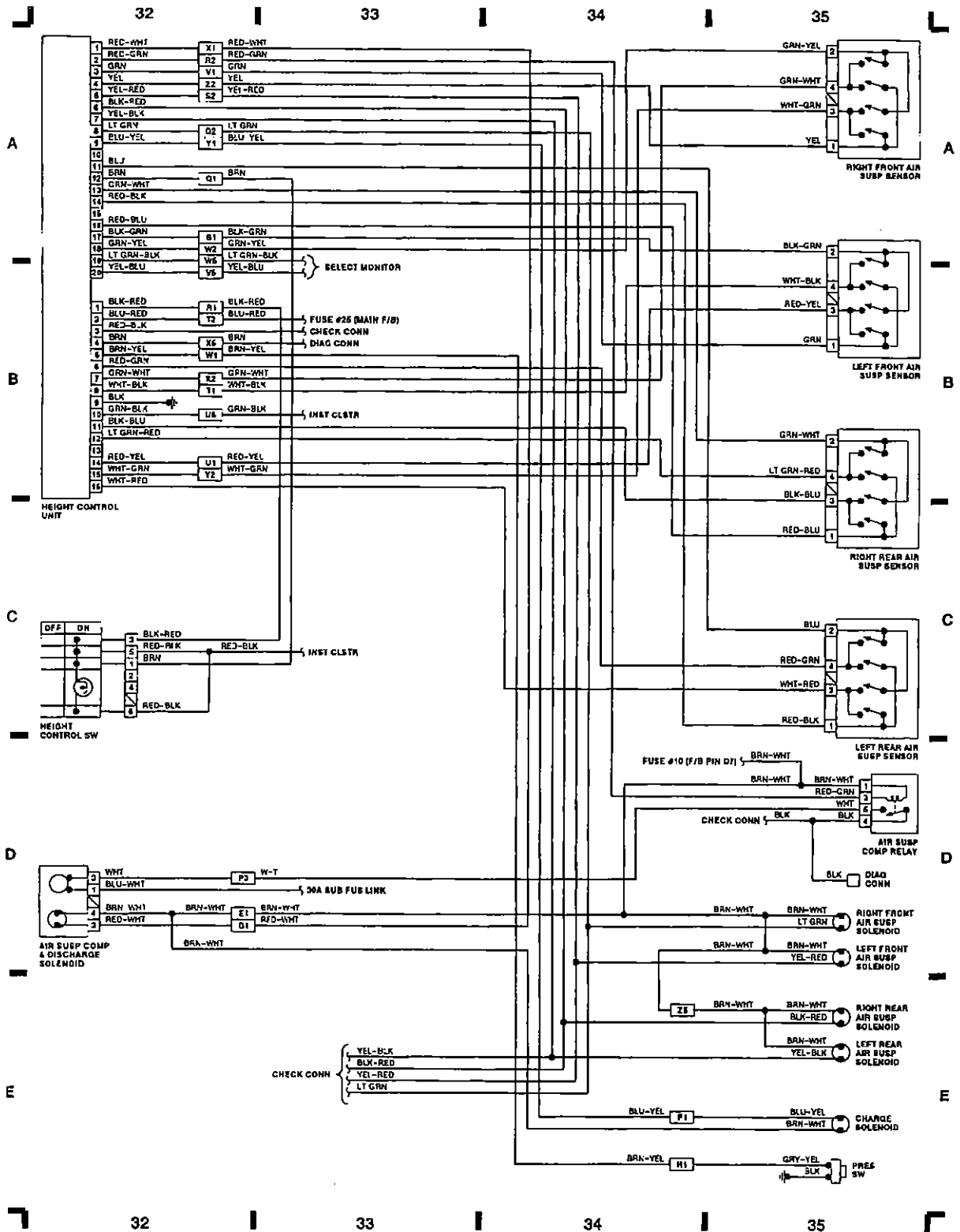

93I03658

Fig. 9: Air Suspension Sensors, Height Control Unit (Grid 32-35)

WIRING DIAGRAMS

Article Text (p. 12)

1992 Subaru Legacy

For Canadian Tire 777 Niagara Street, Welland Ontario (905) 732-7501 Ext. 325

Copyright © 1997 Mitchell International

Saturday, February 20, 1999 05:56PM

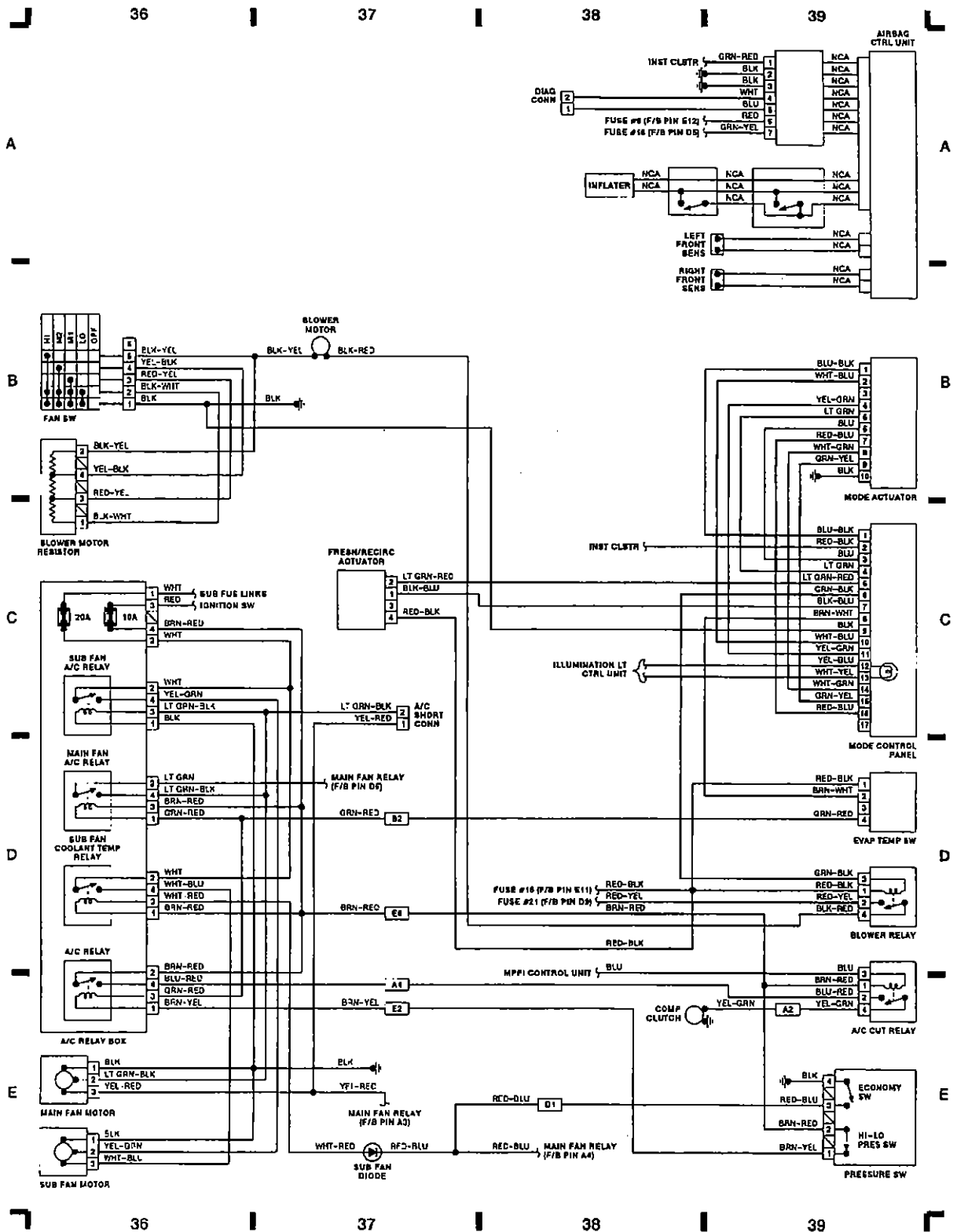

93A03659

Fig. 10: A/C Relay Box, Air Bag Control Unit (Grid 36-39)

WIRING DIAGRAMS

Article Text (p. 13)

1992 Subaru Legacy

For Canadian Tire 777 Niagara Street, Welland Ontario (905) 732-7501 Ext. 325

Copyright © 1997 Mitchell International

Saturday, February 20, 1999 05:56PM

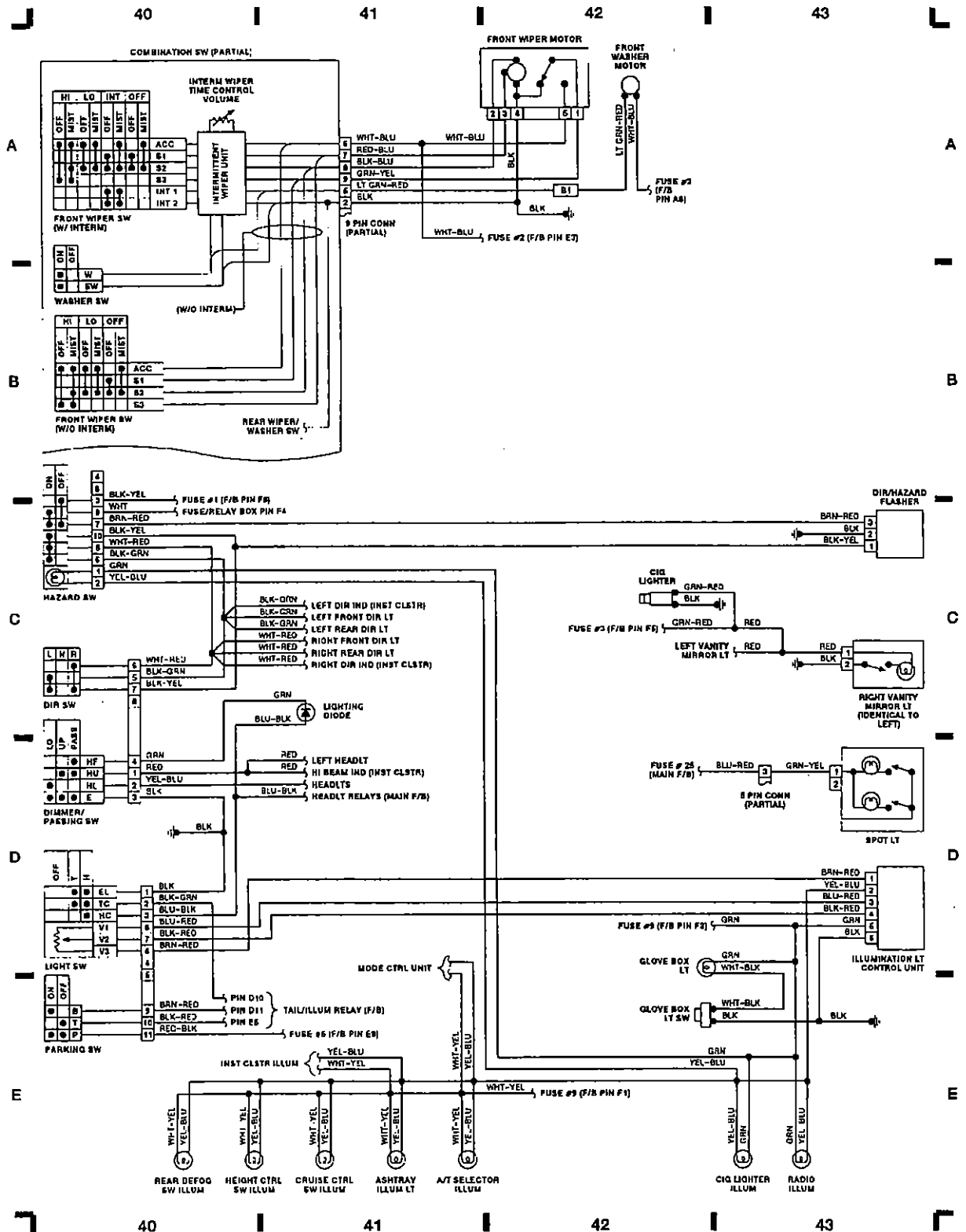

93C03660

Fig. 11: Front Wiper Motor, Hazard Sw (Grid 40-43)

WIRING DIAGRAMS

Article Text (p. 14)

1992 Subaru Legacy

For Canadian Tire 777 Niagara Street, Welland Ontario (905) 732-7501 Ext. 325

Copyright © 1997 Mitchell International

Saturday, February 20, 1999 05:56PM

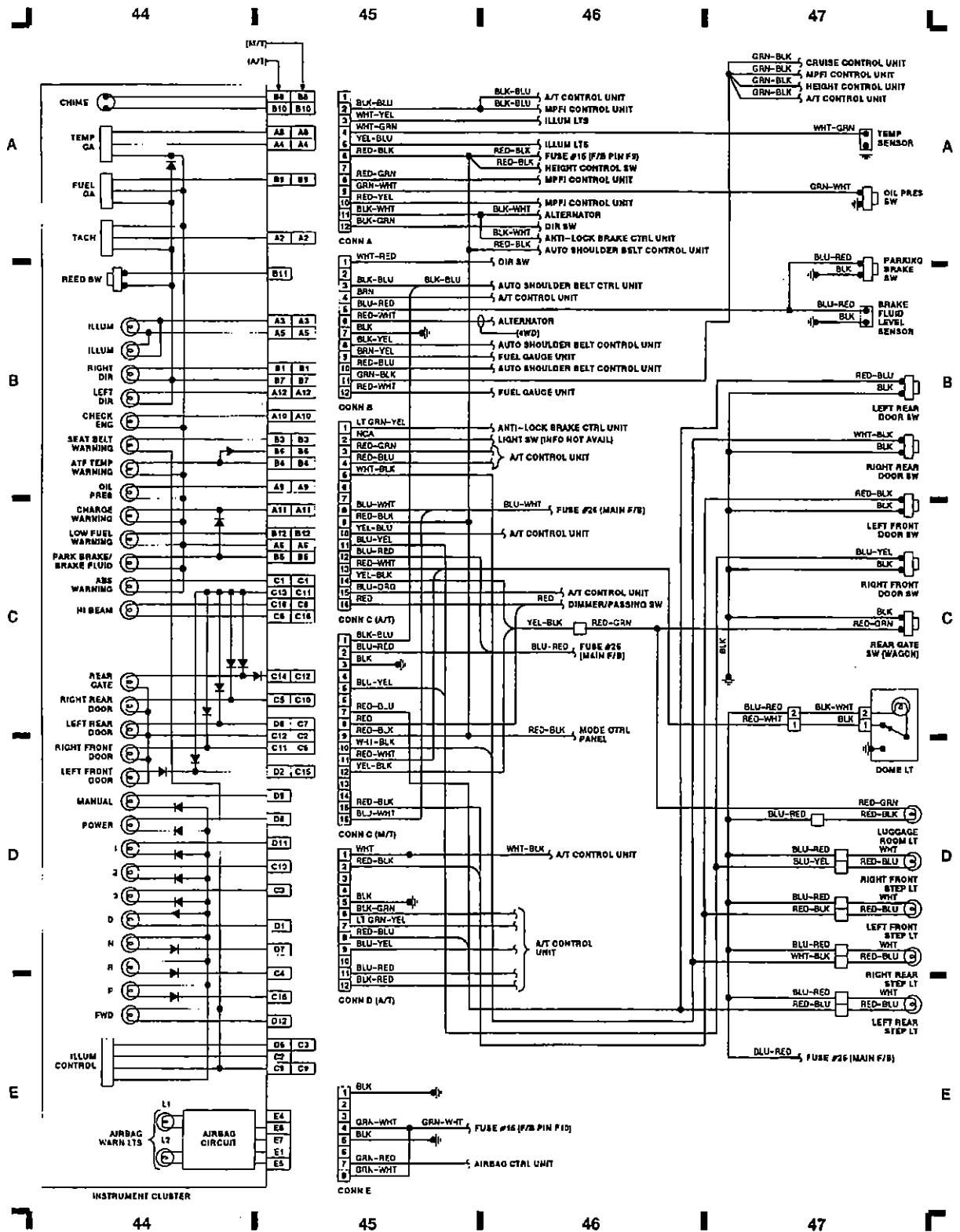

93E03661

Fig. 12: Instrument Cluster, Dome Light (Grid 44-47)

WIRING DIAGRAMS

Article Text (p. 15)

1992 Subaru Legacy

For Canadian Tire 777 Niagara Street, Welland Ontario (905) 732-7501 Ext. 325

Copyright © 1997 Mitchell International

Saturday, February 20, 1999 05:56PM

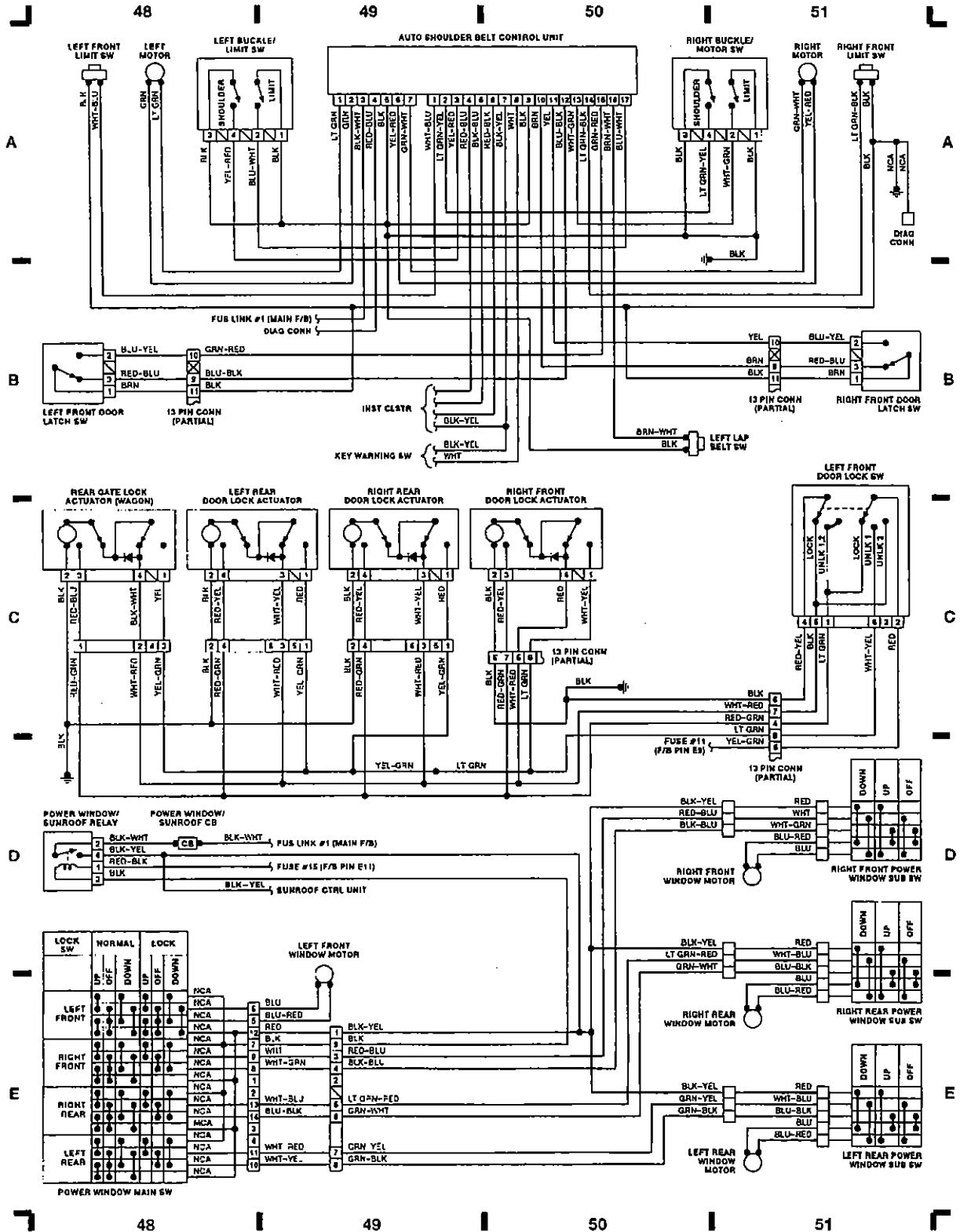

93G03662

Fig. 13: Auto Shoulder Belt Control Unit, Pwr Windows (Grid 48-51)

WIRING DIAGRAMS

Article Text (p. 16)

1992 Subaru Legacy

For Canadian Tire 777 Niagara Street, Welland Ontario (905) 732-7501 Ext. 325

Copyright © 1997 Mitchell International

Saturday, February 20, 1999 05:56PM

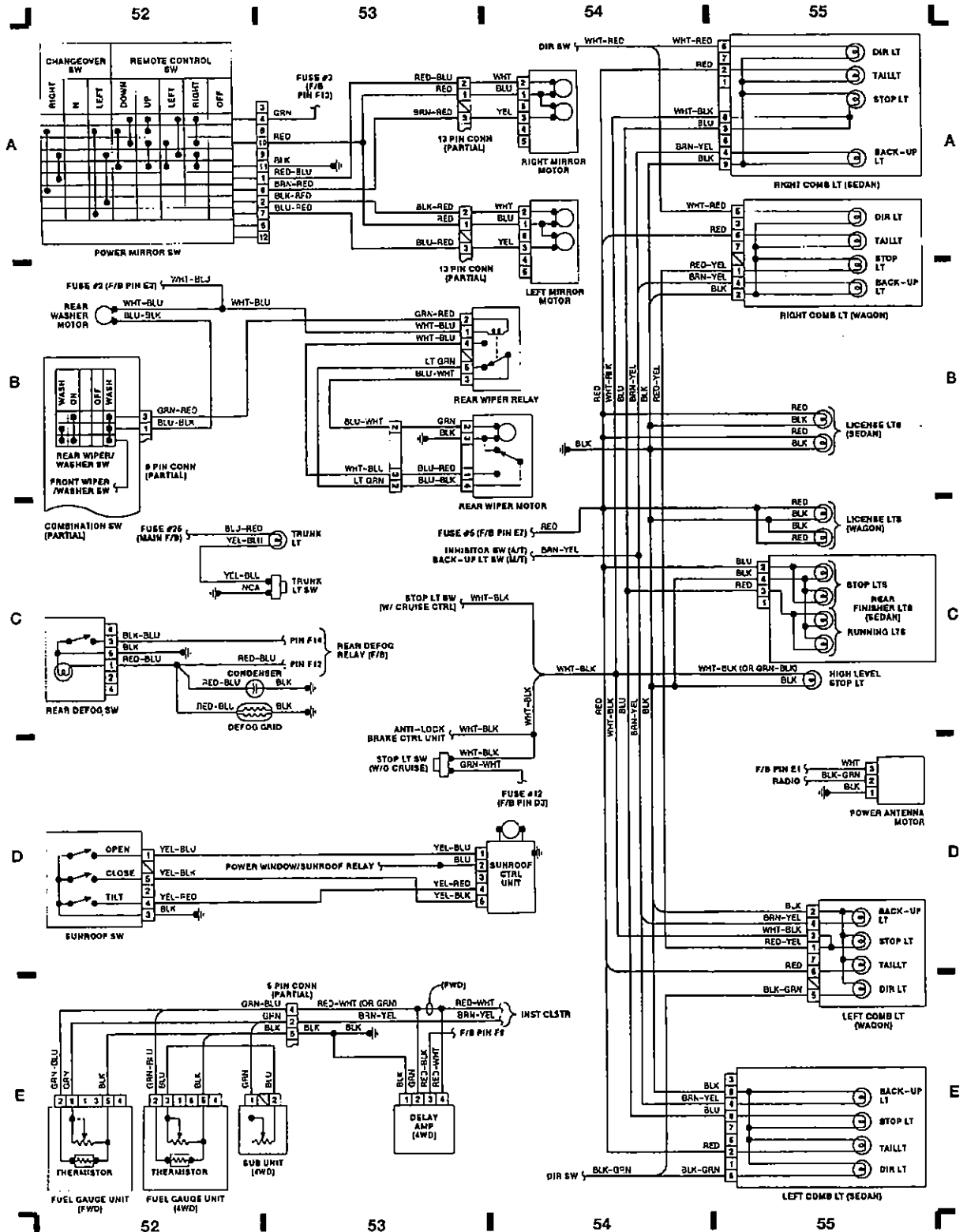

93I03663

Fig. 14: Power Mirror/Sunroof Sw, Tail lights (Grid 52-55)

END OF ARTICLE

ELECTRICAL COMPONENT LOCATOR

Article Text

1992 Subaru Legacy

For Canadian Tire 777 Niagara Street, Welland Ontario (905) 732-7501 Ext. 325

Copyright © 1997 Mitchell International

Saturday, February 20, 1999 04:46PM

ARTICLE BEGINNING

1991-92 SUBARU

Electrical Component Location

Subaru; Legacy

SAFETY PRECAUTION

WARNING: When working on vehicles equipped with Supplemental Restraint System (SRS), never apply electrical voltage to the system. This could cause the SRS (air bag) to be deployed. For complete Air Bag Safety precautions see AIR BAGS article in ACCESSORIES/SAFETY EQUIPMENT Section.

BUZZERS, RELAYS & TIMERS

Component

Component Location

A/C Cut Relay (A/T)

On top of evaporator case.

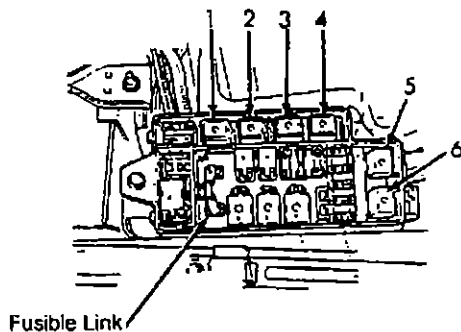

1. A/C Condenser (Sub) Fan Relay
2. A/C Main Fan Relay
3. A/C Condenser (Sub) Fan Coolant Temperature Relay
4. A/C Main Relay
5. Headlight Relay (Left)
6. Headlight Relay (Right)

A/C Condenser (Sub) Fan Relay

In fuse/relay box, in engine compartment.

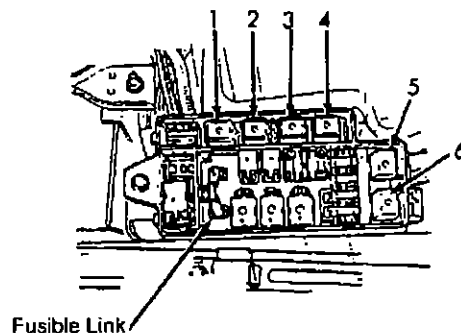

1. A/C Condenser (Sub) Fan Relay
2. A/C Main Fan Relay
3. A/C Condenser (Sub) Fan Coolant Temperature Relay
4. A/C Main Relay
5. Headlight Relay (Left)
6. Headlight Relay (Right)

A/C Condenser (Sub) Fan
Coolant Temperature Relay

In fuse/relay box, in engine compartment.

ELECTRICAL COMPONENT LOCATOR

Article Text (p. 2)

1992 Subaru Legacy

For Canadian Tire 777 Niagara Street, Welland Ontario (905) 732-7501 Ext. 325

Copyright © 1997 Mitchell International

Saturday, February 20, 1999 04:46PM

A/C High Relay

On bottom of blower motor case.

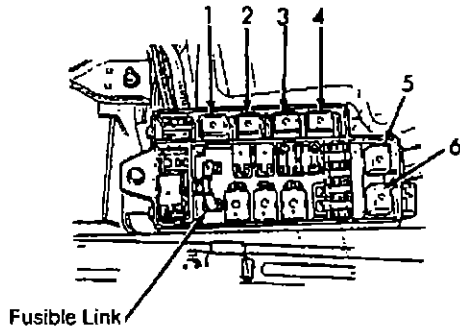

1. A/C Condenser (Sub) Fan Relay
2. A/C Main Fan Relay
3. A/C Condenser (Sub) Fan Coolant Temperature Relay
4. A/C Main Relay
5. Headlight Relay (Left)
6. Headlight Relay (Right)

A/C Main Relay

In fuse/relay box, in engine compartment.

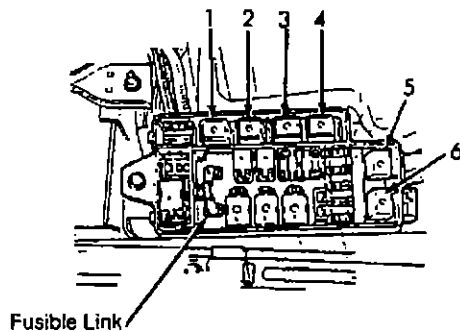

1. A/C Condenser (Sub) Fan Relay
2. A/C Main Fan Relay
3. A/C Condenser (Sub) Fan Coolant Temperature Relay
4. A/C Main Relay
5. Headlight Relay (Left)
6. Headlight Relay (Right)

A/C Main Fan Relay

In fuse/relay box, in engine compartment.

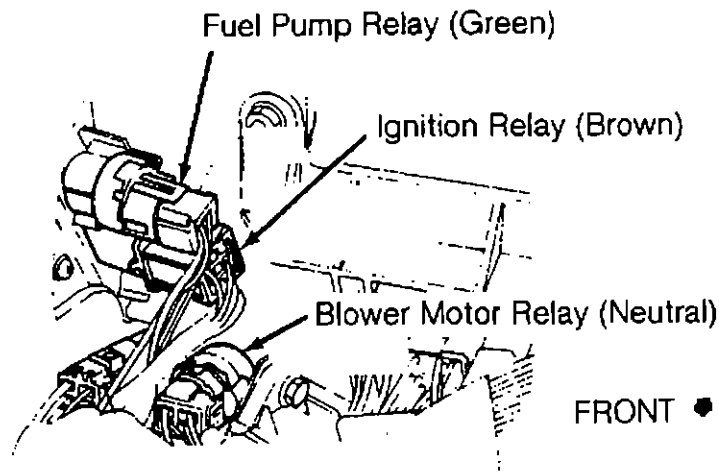

BEHIND LEFT END OF DASHBOARD

93C27575

Blower Motor Relay (Neutral)

Behind left end of dashboard (Neutral connector).

ELECTRICAL COMPONENT LOCATOR

Article Text (p. 3)

1992 Subaru Legacy

For Canadian Tire 777 Niagara Street, Welland Ontario (905) 732-7501 Ext. 325

Copyright © 1997 Mitchell International

Saturday, February 20, 1999 04:46PM

Clutch Relay (M/T)

Behind right kick panel, above cruise control module.

Cruise Control Main Relay

Behind right kick panel, above cruise control module.

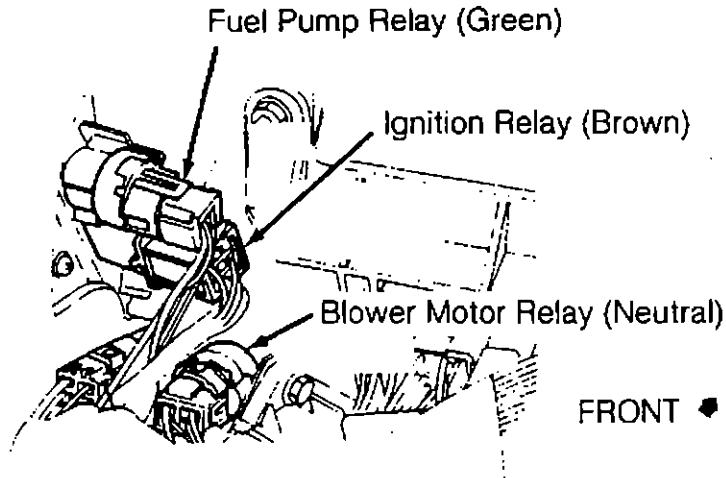

BEHIND LEFT END OF DASHBOARD

93C27575

Fuel Pump Relay (Green)

Behind left end of dashboard (Green connector).

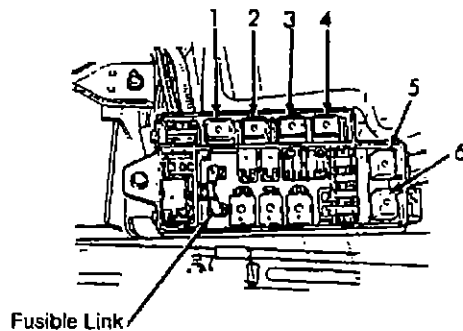

1. A/C Condenser (Sub) Fan Relay
2. A/C Main Fan Relay
3. A/C Condenser (Sub) Fan Coolant Temperature Relay
4. A/C Main Relay
5. Headlight Relay (Left)
6. Headlight Relay (Right)

Headlight Relay (Left & Right)

In fuse/relay box, in engine compartment.

Horn Relay

Behind left kick panel (3-wire connector).

ELECTRICAL COMPONENT LOCATOR

Article Text (p. 4)

1992 Subaru Legacy

For Canadian Tire 777 Niagara Street, Welland Ontario (905) 732-7501 Ext. 325

Copyright © 1997 Mitchell International

Saturday, February 20, 1999 04:46PM

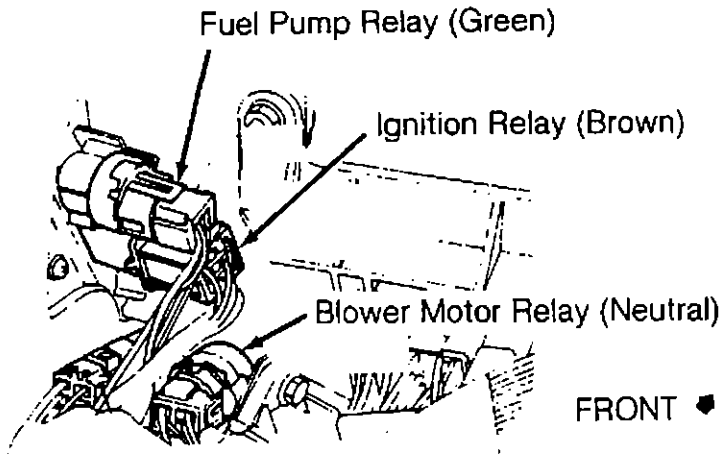

BEHIND LEFT END OF DASHBOARD

93C27575

Ignition Relay (Brown)

Behind left end of dashboard (Brown connector).

Inhibitor Relay (A/T)

Behind right kick panel, above cruise control module.

Intermittent Wiper Unit

Part of combination switch on steering column.

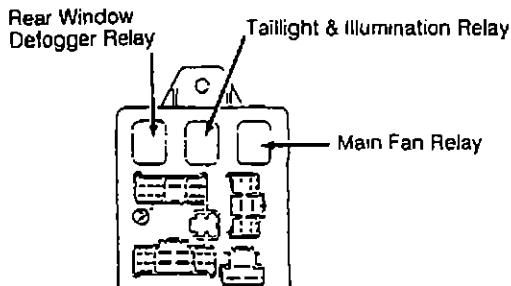

Main Fan Relay

Behind left side of dash, at top of fuse/relay box.

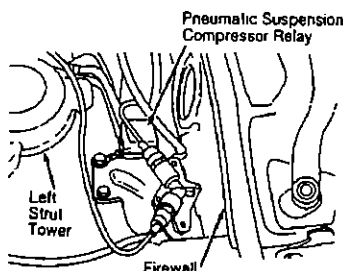

Pneumatic Susp.
Compressor Relay

In engine compartment, on back of left strut tower.

ELECTRICAL COMPONENT LOCATOR

Article Text (p. 5)

1992 Subaru Legacy

For Canadian Tire 777 Niagara Street, Welland Ontario (905) 732-7501 Ext. 325

Copyright © 1997 Mitchell International

Saturday, February 20, 1999 04:46PM

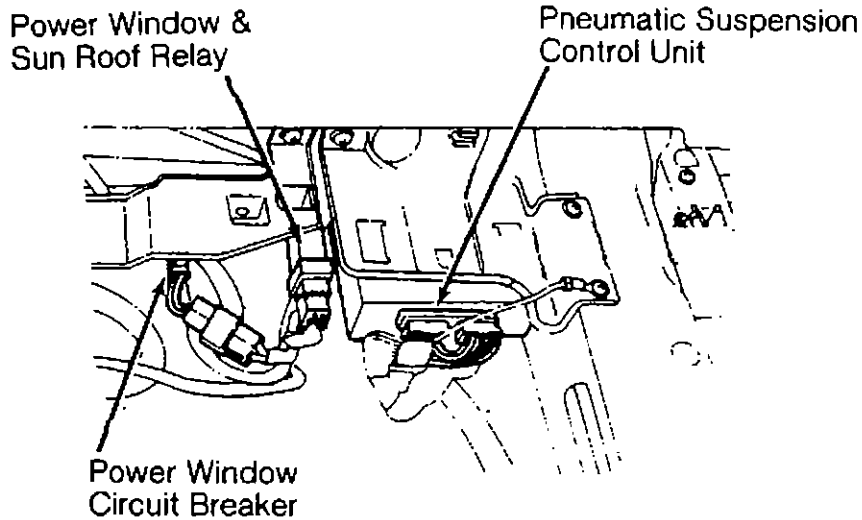

93D27576

TO LEFT OF DRIVER'S SEAT

Power Window Relay

On left side of driver's seat, in floor.

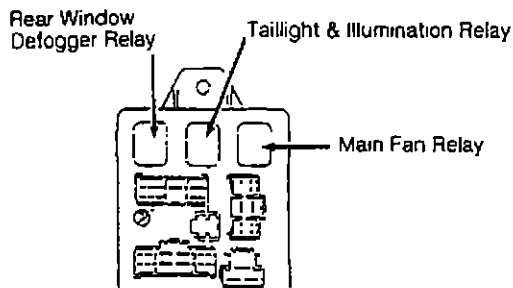

Rear Window Defogger Relay

Behind left side of dash, at top of fuse/relay box.

Rear Wiper Relay (Black)

Behind right rear quarter panel, near wheel well.

Seat Belt Timer

Behind dashboard, to right of center console.

Starter Interlock Relay (M/T)

On brake pedal bracket.

ELECTRICAL COMPONENT LOCATOR

Article Text (p. 6)

1992 Subaru Legacy

For Canadian Tire 777 Niagara Street, Welland Ontario (905) 732-7501 Ext. 325

Copyright © 1997 Mitchell International

Saturday, February 20, 1999 04:46PM

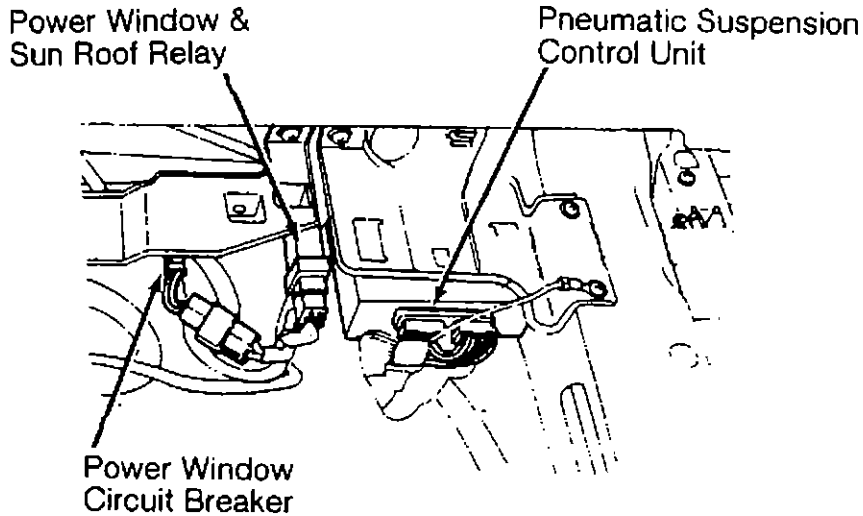

93D27576

TO LEFT OF DRIVER'S SEAT

Sun Roof Relay (Red)

Under left of driver seat.

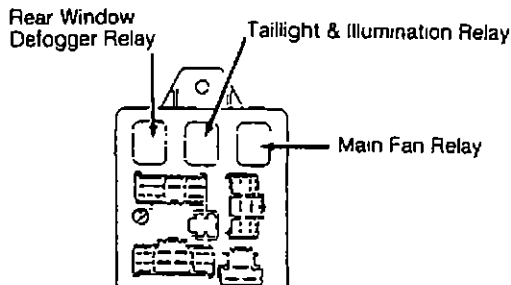

Taillight & Illumination Relay

Behind left side of dashboard,
at top of fuse/relay box.

Turn Signal/Hazard Flasher Unit

Behind dashboard, to right of
center console.

Warning Chime

Part of instrument cluster
(combination meter).

CIRCUIT PROTECTION DEVICES

Component	Component Location
A/C Main Fuse	In fuse/relay box, in engine compartment.

ELECTRICAL COMPONENT LOCATOR

Article Text (p. 8)

1992 Subaru Legacy

For Canadian Tire 777 Niagara Street, Welland Ontario (905) 732-7501 Ext. 325

Copyright © 1997 Mitchell International

Saturday, February 20, 1999 04:47PM

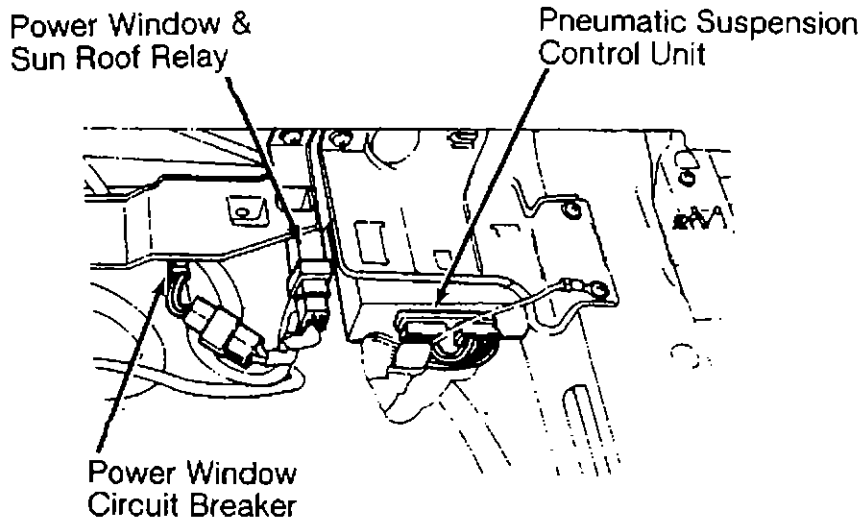

93D27576

TO LEFT OF DRIVER'S SEAT

Power Window Circuit Breaker

On left side of driver's seat,
in floor.

CONTROL UNITS

Component	Component Location
Anti-Lock Brake Control Unit	On right side of front passenger's seat, in floor.
A/T Control Unit	Behind dashboard, to left of steering column.
A/T Shift Lock Control Unit	Behind dashboard, to left of heater core case.
Automatic Seat Belt Control Unit (Except Canada) Sedan	On left trunk wall.
Station Wagon	Behind left rear quarter panel, under speaker.
Cruise Control Unit	Behind right kick panel.
Engine Electronic Control Unit (ECU)	Behind left side of dash.
Illumination Control Unit	Behind dashboard, to right of

ELECTRICAL COMPONENT LOCATOR

Article Text (p. 9)

1992 Subaru Legacy

For Canadian Tire 777 Niagara Street, Welland Ontario (905) 732-7501 Ext. 325

Copyright © 1997 Mitchell International

Saturday, February 20, 1999 04:47PM

center console.

Intermittent Wiper Unit

Part of combination switch on steering column.

Power Window &
Sun Roof Relay

Pneumatic Suspension
Control Unit

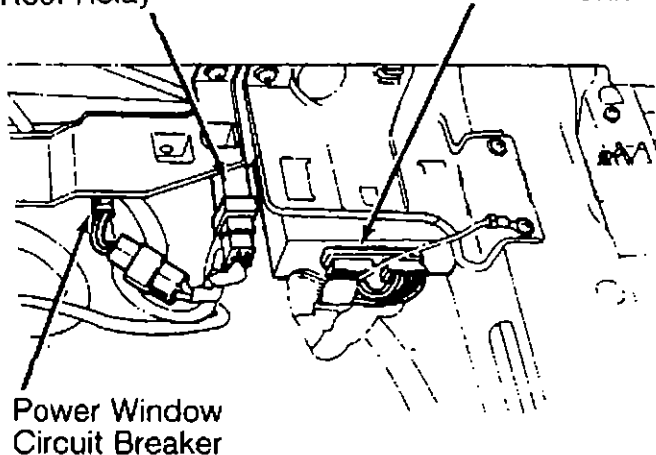

Power Window
Circuit Breaker

93D27576

TO LEFT OF DRIVER'S SEAT

Pneumatic Suspension
Control Unit

On left side of driver's seat,
in floor.

Shift Lock Control Unit (A/T)

Behind dashboard, to right of
center console.

Sun Roof Control Unit

At front center of roof.

MOTORS

Component

Component Location

Automatic Seat Belt Motor

In front door pillar.

Cruise Control Pump

On left rear of inner fender
panel, near frame rail.

Pneumatic Susp. Compressor

To left of battery.

Sun Roof Motor

At front center of roof.

Washer Motor (Front & Rear)

On bottom of washer reservoir.

ELECTRICAL COMPONENT LOCATOR

Article Text (p. 10)

1992 Subaru Legacy

For Canadian Tire 777 Niagara Street, Welland Ontario (905) 732-7501 Ext. 325

Copyright © 1997 Mitchell International

Saturday, February 20, 1999 04:47PM

Windshield Wiper Motor

On left side of firewall.

SENDING UNITS & SENSORS

Component	Component Location
ABS "G" Sensor	On frame rail, under cruise control pump.
A/C-Heater System Ambient Temperature Sensor	On hood lock stay.
Coolant Temperature Sensor	On bottom right side of heater core case.
Intake Air Temp. Sensor	On evaporator case, above upper and lower case seam.
In-Vehicle Temp. Sensor	Left end of A/C control panel.
Sunload Sensor	On top left end of instrument panel, in defroster grille.
A/T Revolution Sensor	On right rear side of transmission.
Airflow Meter	In air intake tube between air cleaner and throttle body.
Anti-Lock Brake System (ABS) G-Sensor (M/T)	In engine compartment, on right front wheel apron.
Speed Sensor	On inboard side of wheel hub.
Brake Fluid Level Sensor	In brake fluid reservoir.
Cam Angle Sensor	On back of left camshaft sprocket cover.

ELECTRICAL COMPONENT LOCATOR

Article Text (p. 11)

1992 Subaru Legacy

For Canadian Tire 777 Niagara Street, Welland Ontario (905) 732-7501 Ext. 325

Copyright © 1997 Mitchell International

Saturday, February 20, 1999 04:47PM

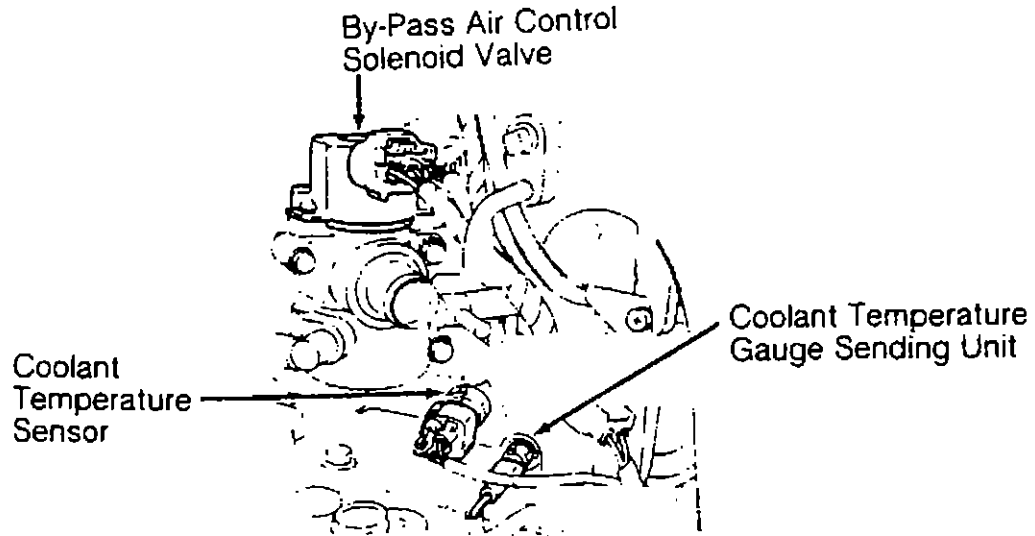

93E27577

**RIGHT REAR CORNER
OF ENGINE**

Coolant Temp. Gauge
Sending Unit

On right rear corner of
engine.

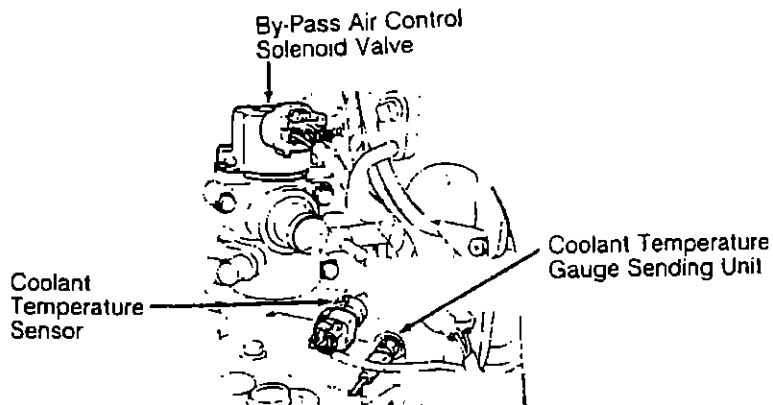

93E27577

**RIGHT REAR CORNER
OF ENGINE**

Coolant Temperature Sensor

On right rear corner of
engine.

TROUBLE CORE 13 - CRANK ANGLE SENSOR

Article Text

1992 Subaru Legacy

For Canadian Tire 777 Niagara Street, Welland Ontario (905) 732-7501 Ext. 325

Copyright © 1997 Mitchell International
Saturday, February 20, 1999 05:38PM

ARTICLE BEGINNING

TECHNICAL SERVICE BULLETIN

SPI TROUBLE CODE 13 (CRANK ANGLE SENSOR) FROM ECU

Model(s): 1988 Subaru STD/GL/DL
 1989 Subaru DL/GL/RX
 1988-91 Subaru XT/XT-6
 1990-95 Subaru Legacy
 1991-95 Subaru Loyale
 1993-95 Subaru Impreza
Group: Engine
Bulletin No.: SSHU 1194-05
Date: November 1994

SERVICE INFORMATION

If you are diagnosing an SPI vehicle for a driveability complaint and there is a Code 13 in the ECU memory, do not replace the crank angle sensor just yet.

It is normal for Code 13 to be found in the ECU memory if the vehicle's engine has stalled for any reason.

We suggest that you clear the ECU memory and road test the vehicle. If Code 13 has come back, and the vehicle did not stall during the road test, then there may be something wrong and a thorough check of the crank angle sensor system may be performed at this time.

END OF ARTICLE

ELECTRICAL COMPONENT LOCATOR

Article Text (p. 12)

1992 Subaru Legacy

For Canadian Tire 777 Niagara Street, Welland Ontario (905) 732-7501 Ext. 325

Copyright © 1997 Mitchell International

Saturday, February 20, 1999 04:47PM

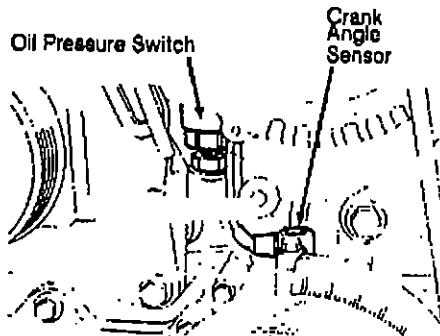

Crank Angle Sensor

At front center of engine, on oil pump.

Knock Sensor

On left rear corner of engine block.

Pneumatic Susp. Height Sensor

Front
Left

Left end of firewall.

Right

Right end of firewall.

Rear
Left

Behind left rear quarter panel.

Right

Behind right rear quarter panel.

Throttle Position Sensor

On throttle body.

SOLENOIDS & SOLENOID VALVES

Component

Component Location

ELECTRICAL COMPONENT LOCATOR

Article Text (p. 13)

1992 Subaru Legacy

For Canadian Tire 777 Niagara Street, Welland Ontario (905) 732-7501 Ext. 325

Copyright © 1997 Mitchell International

Saturday, February 20, 1999 04:47PM

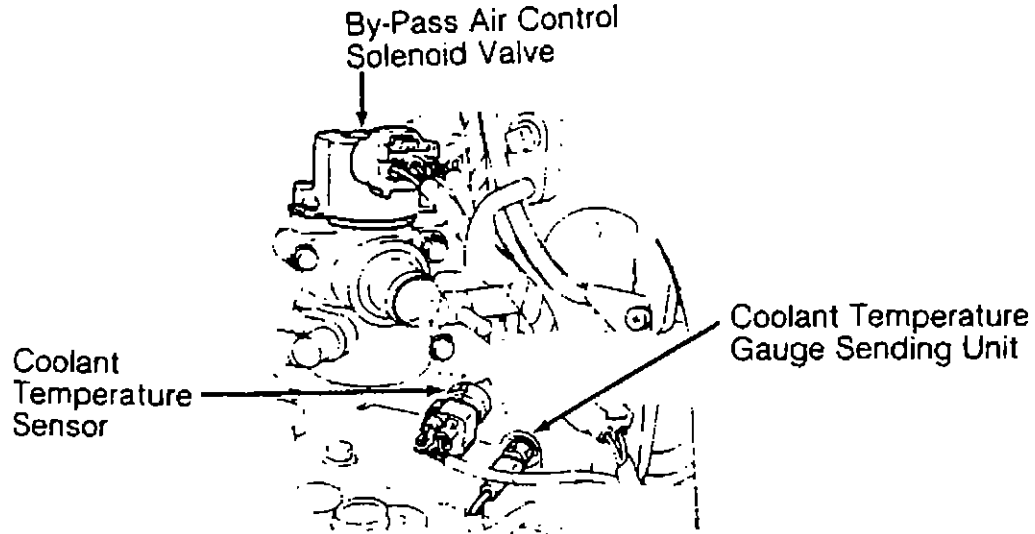

93E27577

RIGHT REAR CORNER OF ENGINE

By-Pass Air Control Sol. Valve	Mounted on top of center of intake manifold.
Canister Purge Control (CPC) Sol.	On right side of engine.
Key Lock Solenoid	On steering column, below ignition key cylinder.
Pneumatic Suspension Charge Solenoid	Part of pneumatic suspension compressor.
Discharge Solenoid	On pneumatic suspension compressor unit bracket.
Strut Solenoid Front	Mounted to back of left and right strut tower.
Rear	On left and right rear
Shift Lock Solenoid	At base of shift lever.

SWITCHES

ELECTRICAL COMPONENT LOCATOR

Article Text (p. 14)

1992 Subaru Legacy

For Canadian Tire 777 Niagara Street, Welland Ontario (905) 732-7501 Ext. 325

Copyright © 1997 Mitchell International

Saturday, February 20, 1999 04:47PM

Component	Component Location
A/C Pressure Switch	On top of receiver-drier.
A/T FWD Switch	Between right strut tower and firewall.
Back-Up Light Switch	On left side of transmission.
Clutch Switch (M/T)	On clutch pedal bracket.
Evaporator Thermostwitch	On top of evaporator case.
Inhibitor Switch (A/T)	On right side of transmission, on shift shaft.
Key Warning Switch	Part of ignition switch.
Neutral Switch	On left side of transmission.

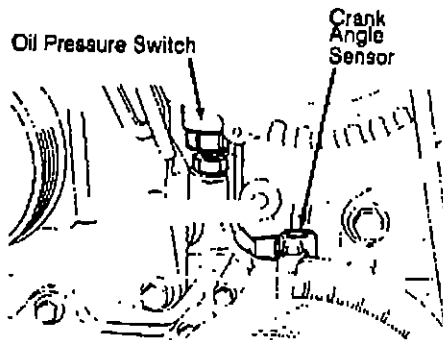

Oil Pressure Switch	On right half of cylinder case, near front of engine.
Parking Brake Switch	At base of parking brake lever.
Pneumatic Susp. Pressure Switch	On pneumatic suspension compressor unit.
Stoplight Switch	On brake pedal bracket.
Throttle Switch	Part of throttle sensor.
Vehicle Speed Sensor Reed Switch	Part of instrument cluster.

MISCELLANEOUS

ELECTRICAL COMPONENT LOCATOR

Article Text (p. 15)

1992 Subaru Legacy

For Canadian Tire 777 Niagara Street, Welland Ontario (905) 732-7501 Ext. 325

Copyright © 1997 Mitchell International

Saturday, February 20, 1999 04:47PM

Component	Component Location
Blower Motor (Fan) Amplifier	On evaporator case.
Blower Motor Resistor Vehicles With Heater Only	Under dashboard, on heater plenum.
Vehicles With A/C	On evaporator case.
Dropping Resistor (A/T)	On right strut tower.
Power Transistor (Ignitor)	At center of firewall.
Stoplight Check Unit	In right rear taillight assembly.
Test Connectors: Check Connector	Behind left side of dash, near heater case (Black).
Diagnostic Connector	Behind left side of dash, near heater case (Black 4-pin).
Diagnosis Connector (Ground)	Behind left side of dash, near heater case (1-pin).
Read Memory Connectors	Behind knee panel, right of steering column (Black).
Select Monitor Connector	Behind left side of dash, near heater case (Yellow).
Test Mode Connectors	Behind knee panel, right of steering column (Green).

END OF ARTICLE

M - VACUUM DIAGRAMS

Fig. 4: Vacuum Diagram (Legacy 2.2L PFI - Turbo)

Courtesy of Subaru of America, Inc.

1992 Subaru Legacy

For Canadian Tire 777 Niagara Street, Welland Ontario (905) 732-7501 Ext. 325

Copyright © 1997 Mitchell International

Saturday, February 20, 1999 05:14PM

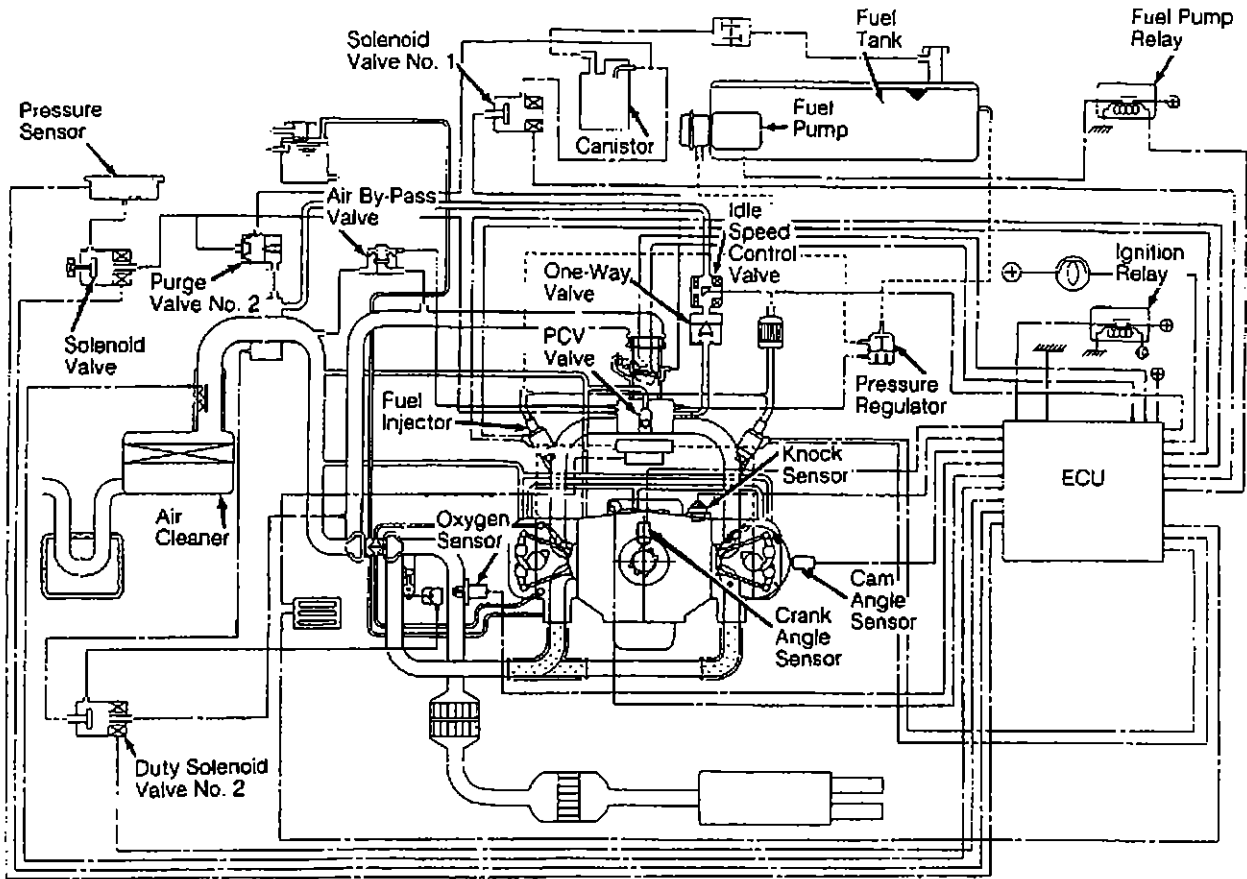

N - REMOVE/INSTALL/OVERHAUL

Screen Printout

1992 Subaru Legacy

For Canadian Tire 777 Niagara Street, Welland Ontario (905) 732-7501 Ext. 325

Copyright © 1997 Mitchell International
Saturday, February 20, 1999 05:19PM

face of throttle chamber. To install, reverse removal procedure.

TURBOCHARGER (LEGACY)

Removal & Installation

Manufacturer does not provide removal and installation procedure. See Fig. 13. During turbocharger removal and installation, do not allow dirt and dust to enter inlet and outlet openings of turbine and blower. If foreign matter is allowed to enter, turbine and blower blades will be damaged. Turbocharger cannot be disassembled or adjusted.

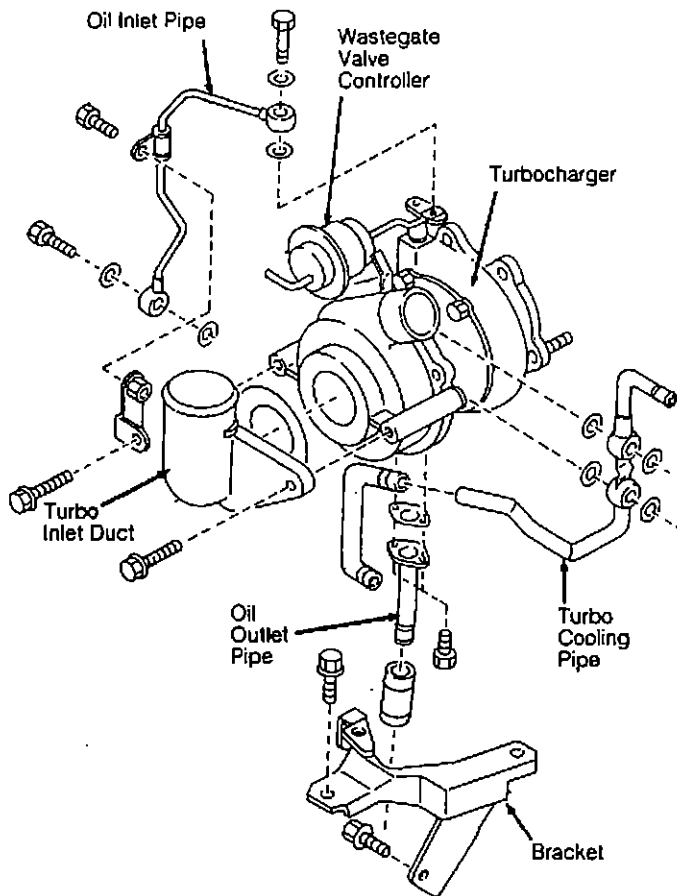

Fig. 13: Exploded View Of Turbocharger Assembly (Legacy)
Courtesy of Subaru of America, Inc.

TORQUE SPECIFICATIONS

TORQUE SPECIFICATIONS TABLE

Application

Ft. Lbs. (N.m)

N - REMOVE/INSTALL/OVERHAUL
Fig. 13: Exploded View Of Turbocharger Assembly (Legacy)
Courtesy of Subaru of America, Inc.
1992 Subaru Legacy

For Canadian Tire 777 Niagara Street, Welland Ontario (905) 732-7501 Ext. 325
Copyright © 1997 Mitchell International
Monday, December 21, 1998 01:58PM

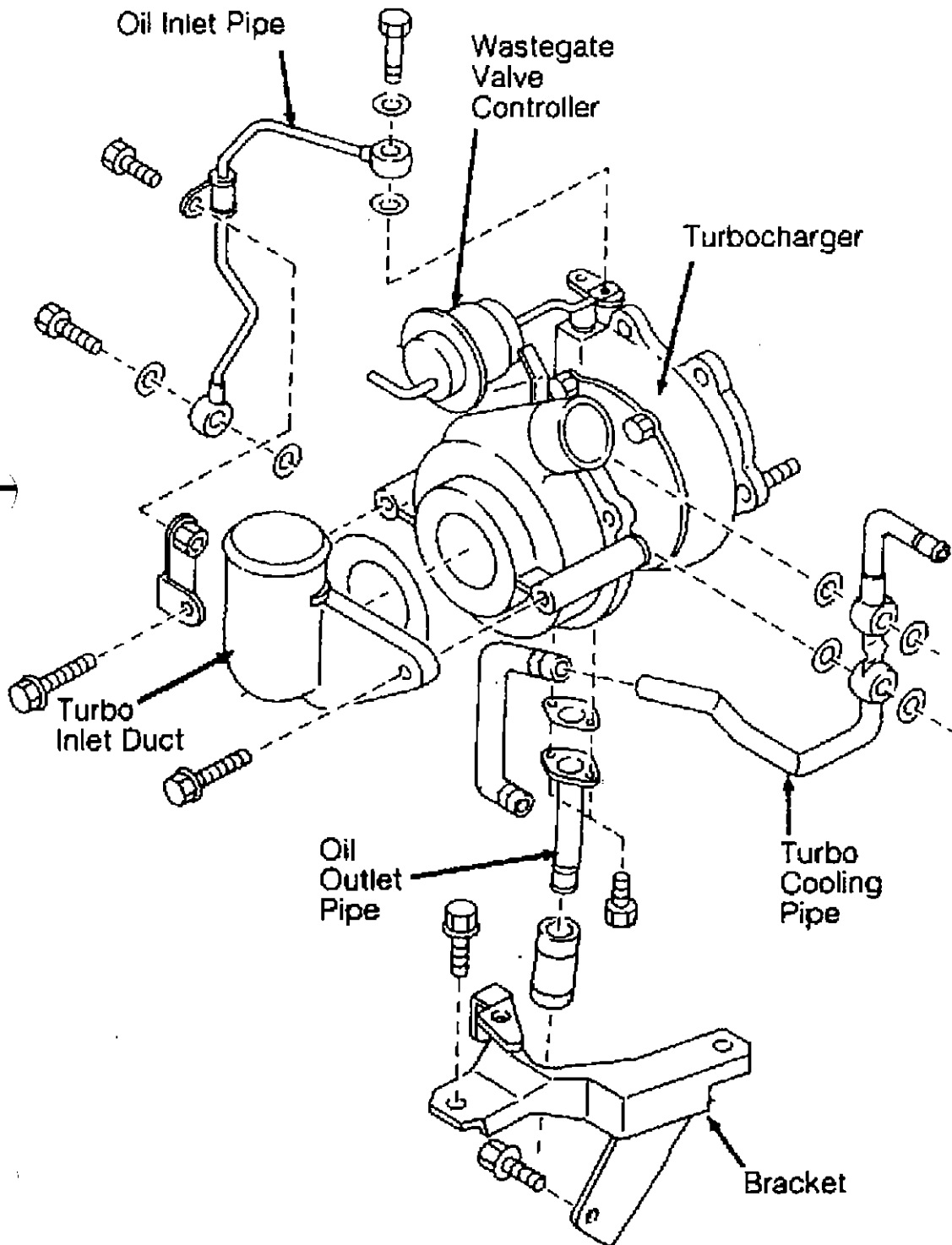

N - REMOVE/INSTALL/OVERHAUL

Screen Printout (p. 2)

1992 Subaru Legacy

For Canadian Tire 777 Niagara Street, Welland Ontario (905) 732-7501 Ext. 325

Copyright © 1997 Mitchell International

Saturday, February 20, 1999 05:19PM

Fuel Rail Bolts (Justy)	10-13	(14-17)
Oxygen Sensor	17-25	(24-34)
Throttle Body Mounting Bolts		
Justy	17-20	(24-26)
Loyale	13-15	(18-21)
Turbocharger Mounting Bolts (Legacy)	16-17	(22-24)

END OF ARTICLE

EFFECTS OF INCORRECT FUEL USE: NEW PROCEDURE

Article Text

1992 Subaru Legacy

For Canadian Tire 777 Niagara Street, Welland Ontario (905) 732-7501 Ext. 325

Copyright © 1997 Mitchell International
Saturday, February 20, 1999 05:23PM

ARTICLE BEGINNING

TECHNICAL SERVICE BULLETIN

USAGE OF PREMIUM FUEL IN TURBOCHARGED MODELS

Model(s): 1992-On Subaru SVX (Turbo Only)
1990-On Subaru Legacy (Turbo Only)
Group: Fuel System
Bulletin No.: 01-137-93
Date: October 13, 1993

SERVICE INFORMATION

The SVX and Legacy turbocharged vehicles require the use of unleaded premium fuel with a rating of 91 AKI (Anti-Knock-Index) or higher.

Unleaded regular fuel with a rating of at least 87 AKI may be used temporarily when premium fuel is not available. However, when a regular fuel is used, the ECU will learn to run on regular fuel even when a small amount is used. This may cause engine knocking, poor driveability and poor fuel economy compared with premium fuel.

Even after refilling the vehicle with premium fuel, the ECU may NOT relearn quickly on how to run on premium fuel. This process will depend on the driving pattern of the user and the length of time the vehicle is driven. The best way to ensure the ECU will fully learn to run on premium fuel is to clear the memory using the Select Monitor. This will set the ECU back to the beginning of the learning mode

NOTE: Disconnecting the battery or the ECU may not clear the learning memory completely.

If you have a vehicle with a driveability complaint make sure you confirm with the owner the type of fuel that is in the tank before you attempt any repairs.

END OF ARTICLE

18-10-92 INCORRECT OIL PUMP COVER TORQUE: NEW SPECIFICATION

Article Text

1992 Subaru Legacy

For Canadian Tire 777 Niagara Street, Welland Ontario (905) 732-7501 Ext. 325

Copyright © 1997 Mitchell International
Monday, December 21, 1998 02:04PM

ARTICLE BEGINNING

TECHNICAL SERVICE BULLETIN

SERVICE MANUAL CORRECTION - OIL PUMP COVER BOLTS TORQUE

Model(s): 1990-93 Subaru Legacy
Group: Engine
Bulletin No.: 18-10-92
Date: December 16, 1992

SERVICE INFORMATION

Please change the oil pump cover tightening torque specifications found on page 3-2, page reference number [W7CO], to read 2.4 - 2.9 NM (2.3 - 2.7 KG M, 17-20 Ft.lb).

END OF ARTICLE

FUEL INJECTOR REPLACEMENT

Article Text

1992 Subaru Legacy

For Canadian Tire 777 Niagara Street, Welland Ontario (905) 732-7501 Ext. 325
Saturday, February 20, 1999 05 25

ARTICLE BEGINNING

TECHNICAL SERVICE BULLETIN

FUEL INJECTOR REPLACEMENT

Model(s): 1993-96 Impreza with EGR
1990-96 Legacy with EGR
1992-96 SVX with EGR
Bulletin No.: 09-34-96
Group: 9 - Cooling Fuel & Exhaust System
Date: September 13, 1996

SERVICE INFORMATION

If you should receive a customer complaint of a Legacy, Impreza, or SVX being difficult to start, after a long cool down period (such as overnight) under extremely cold temperatures and high relative humidity, it has been found that under these conditions ice may build up at the tip of the injector and cause a no start or hard start condition. OBD II equipped vehicles will illuminate the MIL and inhibit trouble codes P0301, P0302, P0303, P0304 (P0305 and P0306 for SVX).

A newly designed injector is now available to prevent the condition. All injectors should be replaced with the newly designed injector as a set of 4 (6 for SVX).

NOTE: Due to the fact that this will only occur under specific driving conditions, as described above, replacement of injectors must be performed only after confirming the cause is related to those conditions.

PLEASE NOTE:

1. The repair procedure outlined in this bulletin is only to be applied on an individual complaint basis and to be supported by a fully documented dealer repair order describing the customer complaint and any trouble codes present.
2. Removed injectors will be remanufactured. Therefore, all injectors must be handled with care to ensure proper core credit. Refer to Service Bulletin #09-33-95 for proper removal techniques to avoid damage. Take care during storage and shipment to avoid damage. When returning injectors, be sure to package each injector in its original box. If the original boxes are not available, be sure each injector in a shipment is individually protected.

The new style injectors have been installed in production, beginning with the following VIN's:

FUEL INJECTOR REPLACEMENT

Article Text (p. 2)

1992 Subaru Legacy

For Canadian Tire 777 Niagara Street, Welland Ontario (905) 732-7501 Ext. 325

Copyrig i r io
r y r y

LEGACY: T*900001 (4-door Sedan)
T*930001 (Station Wagon)
T*970001 (Outback)

IMPREZA: T*412592 (2-door Coupe)
T*512557 (4-door Sedan)
T*813658 (Station Wagon)

SVX: T*100737

PARTS INFORMATION

New style injectors have applicability as listed below:

PARTS INFORMATION TABLE

Identification: Color at Connector Portion	Part Number	SVX	IMPREZA	LEGACY
Red	16611AA260R1	All	All 2.2L	All affected MYs except 96 MY 2.2L Cal. Spec.
Gray	16611AA270R1	N/A	All 1.8L	96 MY 2.2L Cal. Spec.

END OF ARTICLE

INCORRECT DUTY/ID/DATA CHARTS: NEW CHARTS

Article Text

1992 Subaru Legacy

For Canadian Tire 777 Niagara Street, Welland Ontario (905) 732-7501 Ext. 325
 Copyright © 1997 Mitchell International
 Saturday, February 20, 1999 05:26PM

ARTICLE BEGINNING

TECHNICAL SERVICE BULLETIN

UPDATED DATA RANGES - SERVICE MANUAL CORRECTIONS

Model(s): 1990-92 Subaru Legacy
 1992 Subaru SVX
 Group: Electrical, Engine & Automatic Transmission
 Bulletin No.: 18-18-93
 Date: July 1, 1993

SERVICE INFORMATION

Duty Diagrams, Identification Charts and Data Ranges have been updated.

• SELECT MONITOR FUNCTION MODE

Mode: F11	
Condition: Ignition switch ON (Engine OFF) N range	
Specified data: PLDTY F11	
15%	(Throttle is fully open)
100%	(Throttle is fully closed)

1990 Legacy 3-2, 149 [T4A5]

• SELECT MONITOR FUNCTION MODE

Mode: F11	
Condition: Ignition switch ON (Engine OFF) N range	
Specified data: PLDTY F11	
5% (TURBO)	(Throttle is fully open)
15% (Non-TURBO)	
100%	(Throttle is fully closed)

1991 Legacy 3-2, 149 [T4A5]
 1992 Legacy 3-2, 183 [T6A5]

• SELECT MONITOR FUNCTION MODE

Mode: F11	
Condition: Ignition switch ON (Engine OFF) N range	
Specified data: PLDTY F11	
5%	(Throttle is fully open)
100%	(Throttle is fully closed)

1992 SVX 3-2, 179 [T5A5]

Fig. 1: Updated Diagram For Selecting Monitor Function Mode

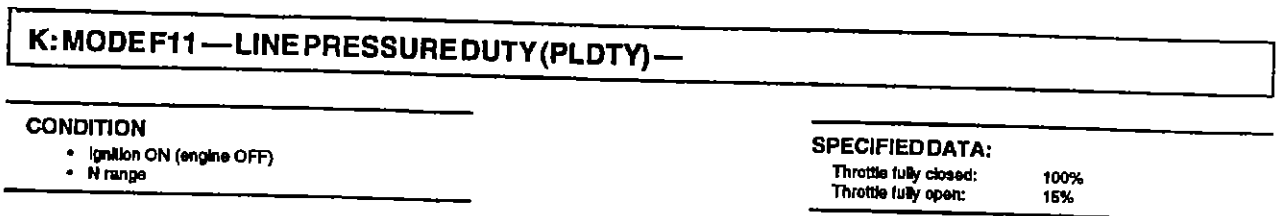

1990 Legacy 3-2, 177 [T6K0]

Fig. 2: Updated Line Pressure Duty Diagram (1990 Legacy)

INCORRECT DUTY/ID/DATA CHARTS: NEW CHARTS

Article Text (p. 2)

1992 Subaru Legacy

For Canadian Tire 777 Niagara Street, Welland Ontario (905) 732-7501 Ext. 325

Copyright © 1997 Mitchell International
Saturday, February 20, 1999 05:26PM

K: MODE F11 — LINE PRESSURE DUTY (PLDTY) —

CONDITION

- Ignition ON (engine OFF)
- N range

SPECIFIED DATA:

Throttle fully closed:	100%	
Throttle fully open:	15%	(Non-TURBO)
	5%	(TURBO)

1991 Legacy 3-2, 177 [T5K0]

1992 Legacy 3-2, 211 [T6K0]

94H51364

Fig. 3: Updated Line Pressure Duty Diagram (1991-92 Legacy)

K: MODE F11 — LINE PRESSURE DUTY (PLDTY) —

CONDITION

- Ignition ON (engine OFF)
- N range

SPECIFIED DATA:

Throttle fully closed:	100%
Throttle fully open:	5%

1992 SVX 3-2, 209 [T6K0]

94I51365

Fig. 4: Updated Line Pressure Duty Diagram (1992 SVX)

NOTE:

Use the Select Monitor with the appropriate cartridge to determine the PLDTY%. Refer to **Trouble Shooting Chart with Select Monitor.**

1990 Legacy 3-2, 91 [W3EO]

1991 Legacy 3-2, 91 [W3EO]

1992 Legacy 3-2, 125 [W3DO]

Place this note on the bottom left of the indicated page under item 5

94J51366

Fig. 5: Updated Cartridge I.D. Chart for Select Monitor

INCORRECT DUTY/ID/DATA CHARTS: NEW CHARTS

Article Text (p. 3)

1992 Subaru Legacy

For Canadian Tire 777 Niagara Street, Welland Ontario (905) 732-7501 Ext. 325

Copyright © 1997 Mitchell International

Saturday, February 20, 1999 05:26PM

Range	RPM	PLDTY%	Pressure
P	600 - 800	100	440.96 - 564.98 (4.48 - 5.74, 64 - 82)
R	600 - 800	100	585.85 - 689.00 (5.95 - 7.00, 85 - 100)
	Stall	5	7410.34-1584.70 (14.42-16.10, 208-230)
D	600 - 800	100	440.96 - 564.98 (4.48 - 5.74, 64 - 82)
	Stall	15	888.81 - 1026.61 (9.03 - 10.43, 129 - 149)
3 Manual Button OFF	600 - 800	100	440.96 - 564.98 (4.48 - 5.74, 64 - 82)
	Stall	15	888.81 - 1026.61 (9.03 - 10.43, 129 - 149)
3 Manual Button On	600 - 800	100	440.96 - 564.98 (4.48 - 5.74, 64 - 82)
	Stall	5	1143.74-1281.54 (11.62-13.02, 166-186)
2 Manual Button OFF	600 - 800	100	440.96 - 564.98 (4.48 - 5.74, 64 - 82)
	Stall	15	888.81 - 1026.61 (9.03 - 10.43, 129 - 149)
2 Manual Button On	600 - 800	100	440.96 - 564.98 (4.48 - 5.74, 64 - 82)
	Stall	5	1143.74-1281.54 (11.62-13.02, 166-186)
1	600 - 800	100	440.96 - 564.98 (4.48 - 5.74, 64 - 82)
	Stall	15	888.81 - 1026.61 (9.03 - 10.43, 129 - 149)

1990 Legacy 3-2, 91 [W3EO]

94A51367

Fig. 6: Updated A/T Data Ranges (1990 Legacy)

INCORRECT DUTY/ID/DATA CHARTS: NEW CHARTS

Article Text (p. 4)

1992 Subaru Legacy

For Canadian Tire 777 Niagara Street, Welland Ontario (905) 732-7501 Ext. 325

Copyright © 1997 Mitchell International

Saturday, February 20, 1999 05:26PM

Unit=kPa (kg/cm², psi)

Range	RPM	PLDTY%	Pressure
P	600 - 800	100	440.96 - 564.98 (4.48 - 5.74, 64 - 82)
R	600 - 800	100	585.65 - 689.00 (5.95 - 7.00, 85 - 100)
	Stall	5	1419.34-1584.70(14.42-16.10,206-230)
D	600 - 800	100	440.96 - 564.98 (4.48 - 5.74, 64 - 82)
	Stall	15	888.81 - 1026.61 (9.03 - 10.43, 129 - 149)
	Stall Turbo	5	1143.74-1281.54(11.62-13.02,166-186)
3 Manual Button Off	600 - 800	100	440.96 - 564.98 (4.48 - 5.74, 64 - 82)
	Stall	15	888.81 - 1026.61 (9.03 - 10.43, 129 - 149)
	Stall Turbo	5	1143.74-1281.54(11.62-13.02,166-186)
3 Manual Button On	600 - 800	100	440.96 - 564.98 (4.48 - 5.74, 64 - 82)
	Stall	5	1143.74-1281.54(11.62-13.02,166-186)
2 Manual Button Off	600 - 800	100	440.96 - 564.98 (4.48 - 5.74, 64 - 82)
	Stall	15	888.81 - 1026.61 (9.03 - 10.43, 129 - 149)
	Stall Turbo	5	1143.74-1281.54(11.62-13.02,166-186)
2 Manual Button On	600 - 800	100	440.96 - 564.98 (4.48 - 5.74, 64 - 82)
	Stall	5	1143.74-1281.54(11.62-13.02,166-186)
1	600 - 800	100	440.96 - 564.98 (4.48 - 5.74, 64 - 82)
	Stall	15	888.81 - 1026.61 (9.03 - 10.43, 129 - 149)
	Stall Turbo	5	1143.74-1281.54(11.62-13.02,166-186)

1991 Legacy 3-2, 91 [W3EO]
1992 Legacy 3-2, 125 [W3DO]

94B51368

Fig. 7: Updated A/T Data Ranges (1991-92 Legacy)

END OF ARTICLE

LOW RVP FUEL EFFECTS: NEW A/T ECU-ROM INSTALLATION

Article Text

1992 Subaru Legacy

For Canadian Tire 777 Niagara Street, Welland Ontario (905) 732-7501 Ext. 325

Copyright © 1997 Mitchell International

Saturday, February 20, 1999 05:36PM

ARTICLE BEGINNING

TECHNICAL SERVICE BULLETIN

EFFECTS OF LOW RVP FUEL ON COLD STARTABILITY/DRIVEABILITY

Model: ALL 1992 LEGACY A/T AND 1992 SVX
Date: 12-31-92
No: 02-87-92, 02-87-92R

The Clean Air Act of 1990 required that fuel volatility of gasoline sold at retail be reduced at summer months (June through September 15). In 1992, the EPA implemented Phase II requirement which further lowered the acceptable vapor pressure to 9.0 psi. In some areas, the regulation requires vapor pressure be no greater than 7.8 psi. Volatility is the term used to describe the fuel's ability to vaporize, or change from a liquid to a vapor. Low volatility gasoline helps reduce hydrocarbon emissions from evaporated fuel. "RVP" is the abbreviation for "Reid Vapor Pressure", a method used to measure fuel vapor pressure. This requirement is needed to protect our environment and improve air quality.

The downside of this regulation is its effect on engine cold starting and cold drive away during summer months. This complaint only occurs for a very short period after start-up and does not severely hamper the driveability. It is important that our customers are aware of the availability of these low RVP fuels and their effect. The few moments of engine roughness are a small inconvenience when the overall improvement of the atmosphere is considered. We all have an obligation to improve air quality and we are sure that Subaru customers wish to share in this endeavor to improve our air quality.

It is important to note that some "low RVP fuel" may be available beyond the summer months, depending on supply, temperature and regional requirements. Summer type temperatures can also be encountered during winter months in some areas. Therefore, engine cold starting and driveability may be affected throughout the year.

Our investigation has proven that there is variation in fuel quality and vapor pressure among retail gasoline supplies. In many cases, the cold start complaint can be reduced or eliminated by changing fuel brands or stations.

In the interest of customer satisfaction, we have developed a ROM for the ECU of 1992 Legacy automatic transmission and SVX vehicles whose owners cannot accept the effects of low RVP fuel. Installation of the ROM should only be performed after explanation of the above to the owner and after trying a different brand of fuel.

This ROM will not totally alleviate the complaint. Also, there is no countermeasure available for manual transmission Legacy or other models. Our experience shows that these vehicles have few complaints

LOW RVP FUEL EFFECTS: NEW A/T ECU-ROM INSTALLATION

Article Text (p. 2)

1992 Subaru Legacy

For Canadian Tire 777 Niagara Street, Welland Ontario (905) 732-7501 Ext. 325

Copyright © 1997 Mitchell International

Saturday, February 20, 1999 05:36PM

and they can be resolved using a different brand of fuel.

Naturally, you must confirm that the engine is operating properly by basic checks of mechanical and fuel management systems prior to installing the ROM.

This ROM will also help reduce the occurrence of source detonation or "pinging" on 92MY Legacys.

ROM INSTALLATION PROCEDURES:

1. Remove battery negative terminal.
2. Hands must be clean and free of dirt and grease prior to handling ROM.
3. Remove static charge from your body by momentarily touching an earth ground, such as a cold water pipe, metal building support beam or clean metal area of vehicle.
4. Remove ECU and its top cover by removing 6 Phillips head screws.
5. Locate the ROM socket and remove the protective tape.
6. Align the notch in the new ROM with the notch in the ROM socket. See Figure 1. It is very important that the notches are located on the same side to prevent permanent damage to the control unit. Insert the ROM pins into the socket receptacles as follows:
 - a) Install the pins on one side of the ROM.
 - b) Using a pencil (non-metallic) laid sideways against the unseated pins, press in on the pencil until the pins line up. Make sure all pins are aligned.
 - c) Press down on the ROM to fully seat it into the socket.
7. Locate the tan resistor. See Figure 1. Remove the resistor by carefully cutting the two leads near the circuit board. This resistor must be removed to activate the ROM. Do not remove the resistor using a solder iron. This will damage the board.

NOTE: If the "TAN" resistor is not found in the location as illustrated, and a ROM chip was already found in the ROM board. DO NOT cut an other resistor because permanent damage to the ECU will occur.

8. Reinstall the ECU cover.
9. Reinstall the ECU.
10. Reinstall the negative battery terminal.
11. Clear memory using Select Monitor. Turn the ignition key to the "ON" position. Do not start the engine. If the check engine light is not illuminated, re-check ROM installation. DO NOT start vehicle.

These ROMs are available in limited supply through your RDC.

PARTS INFORMATION

PART NUMBER	APPLICABILITY
-------------	---------------

LOW RVP FUEL EFFECTS: NEW A/T ECU-ROM INSTALLATION

Article Text (p. 3)

1992 Subaru Legacy

For Canadian Tire 777 Niagara Street, Welland Ontario (905) 732-7501 Ext. 325

Copyright © 1997 Mitchell International
Saturday, February 20, 1999 05:36PM

22677AA040	1992 SVX
22677AA020	1992 LEGACY A/T

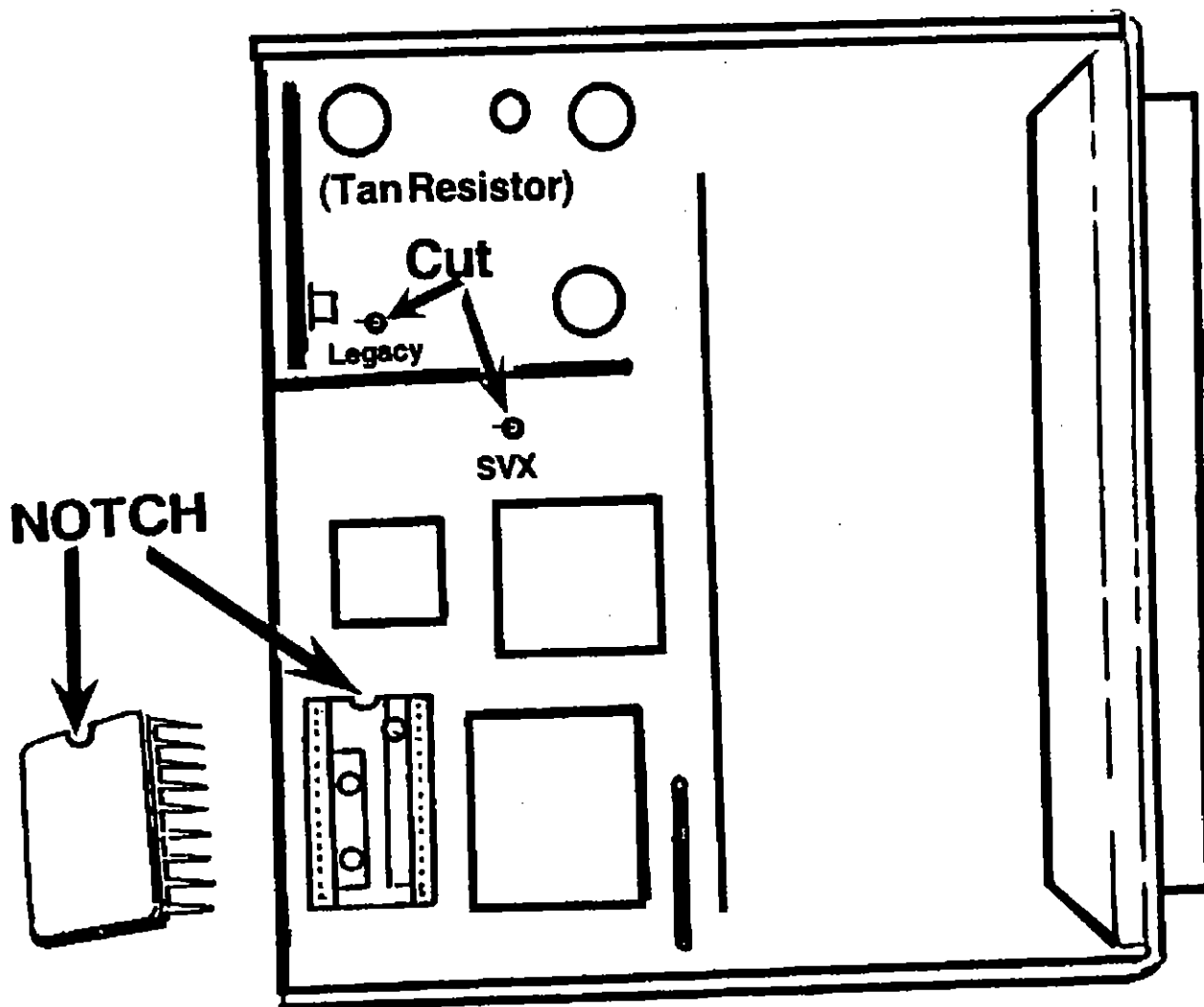

93A50385

Fig. 1: ROM Chip Installation

END OF ARTICLE

OMITTED FUEL GAUGE DELAY AMPLIFIER: NOT USED IN USA

Article Text

1992 Subaru Legacy

For Canadian Tire 777 Niagara Street, Welland Ontario (905) 732-7501 Ext. 325

Copyright © 1997 Mitchell International
Saturday, February 20, 1999 05:38PM

ARTICLE BEGINNING

TECHNICAL SERVICE BULLETIN

ALL WHEEL DRIVE (AWD) FUEL GAUGE

Model(s): 1990-93 Subaru Legacy
Group: Electrical
Bulletin No.: SSHU 493-06
Date: April 1993

SERVICE INFORMATION

We have received several Technical Service Help Line calls about the location and part number of the delay amplifier. The delay amplifier is not used in a U.S.A. specification Subaru Legacy.

END OF ARTICLE